

**PRIME  
X399-A**

**ASUS®**

**Motherboard**

**Copyright© 2018 ASUSTeK COMPUTER INC. All Rights Reserved.**

No part of this manual, including the products and software described in it, may be reproduced, transmitted, transcribed, stored in a retrieval system, or translated into any language in any form or by any means, except documentation kept by the purchaser for backup purposes, without the express written permission of ASUSTeK COMPUTER INC. ("ASUS").

Product warranty or service will not be extended if: (1) the product is repaired, modified or altered, unless such repair, modification of alteration is authorized in writing by ASUS; or (2) the serial number of the product is defaced or missing.

ASUS PROVIDES THIS MANUAL "AS IS" WITHOUT WARRANTY OF ANY KIND, EITHER EXPRESS OR IMPLIED, INCLUDING BUT NOT LIMITED TO THE IMPLIED WARRANTIES OR CONDITIONS OF MERCHANTABILITY OR FITNESS FOR A PARTICULAR PURPOSE. IN NO EVENT SHALL ASUS, ITS DIRECTORS, OFFICERS, EMPLOYEES OR AGENTS BE LIABLE FOR ANY INDIRECT, SPECIAL, INCIDENTAL, OR CONSEQUENTIAL DAMAGES (INCLUDING DAMAGES FOR LOSS OF PROFITS, LOSS OF BUSINESS, LOSS OF USE OR DATA, INTERRUPTION OF BUSINESS AND THE LIKE), EVEN IF ASUS HAS BEEN ADVISED OF THE POSSIBILITY OF SUCH DAMAGES ARISING FROM ANY DEFECT OR ERROR IN THIS MANUAL OR PRODUCT.

SPECIFICATIONS AND INFORMATION CONTAINED IN THIS MANUAL ARE FURNISHED FOR INFORMATIONAL USE ONLY, AND ARE SUBJECT TO CHANGE AT ANY TIME WITHOUT NOTICE, AND SHOULD NOT BE CONSTRUED AS A COMMITMENT BY ASUS. ASUS ASSUMES NO RESPONSIBILITY OR LIABILITY FOR ANY ERRORS OR INACCURACIES THAT MAY APPEAR IN THIS MANUAL, INCLUDING THE PRODUCTS AND SOFTWARE DESCRIBED IN IT.

Products and corporate names appearing in this manual may or may not be registered trademarks or copyrights of their respective companies, and are used only for identification or explanation and to the owners' benefit, without intent to infringe.

**Offer to Provide Source Code of Certain Software**

This product contains copyrighted software that is licensed under the General Public License ("GPL"), under the Lesser General Public License Version ("LGPL") and/or other Free Open Source Software Licenses. Such software in this product is distributed without any warranty to the extent permitted by the applicable law. Copies of these licenses are included in this product.

Where the applicable license entitles you to the source code of such software and/or other additional data, you may obtain it for a period of three years after our last shipment of the product, either

(1) for free by downloading it from <https://www.asus.com/support/>

or

(2) for the cost of reproduction and shipment, which is dependent on the preferred carrier and the location where you want to have it shipped to, by sending a request to:

ASUSTeK Computer Inc.  
Legal Compliance Dept.  
15 Li Te Rd.,  
Beitou, Taipei 112  
Taiwan

In your request please provide the name, model number and version, as stated in the About Box of the product for which you wish to obtain the corresponding source code and your contact details so that we can coordinate the terms and cost of shipment with you.

The source code will be distributed WITHOUT ANY WARRANTY and licensed under the same license as the corresponding binary/object code.

This offer is valid to anyone in receipt of this information.

ASUSTeK is eager to duly provide complete source code as required under various Free Open Source Software licenses. If however you encounter any problems in obtaining the full corresponding source code we would be much obliged if you give us a notification to the email address [gpl@asus.com](mailto:gpl@asus.com), stating the product and describing the problem (please DO NOT send large attachments such as source code archives, etc. to this email address).

# Contents

Safety information.....	v
About this guide.....	vi
PRIME X399-A specifications summary.....	viii
Package contents.....	xii
Installation tools and components.....	xiii

## Chapter 1: Product Introduction

<b>1.1</b>	<b>Motherboard overview.....</b>	<b>1-1</b>
1.1.1	Before you proceed.....	1-1
1.1.2	Motherboard layout.....	1-2
1.1.3	Central Processing Unit (CPU).....	1-4
1.1.4	System memory.....	1-5
1.1.5	Expansion slots.....	1-7
1.1.6	Jumpers, buttons and holes.....	1-9
1.1.7	Onboard LEDs.....	1-11
1.1.8	Internal connectors.....	1-17

## Chapter 2: Basic Installation

<b>2.1</b>	<b>Building your PC system.....</b>	<b>2-1</b>
2.1.1	CPU installation.....	2-1
2.1.2	CPU heatsink and fan assembly installation.....	2-3
2.1.3	Motherboard installation.....	2-4
2.1.4	DIMM installation.....	2-6
2.1.5	ATX power connection.....	2-7
2.1.6	SATA device connection.....	2-8
2.1.7	Front I/O connector.....	2-9
2.1.8	Expansion card installation.....	2-10
2.1.9	M.2 installation.....	2-11
<b>2.2</b>	<b>BIOS update utility.....</b>	<b>2-12</b>
<b>2.3</b>	<b>Motherboard rear and audio connections.....</b>	<b>2-13</b>
2.3.1	Rear I/O connection.....	2-13
2.3.2	Audio I/O connections.....	2-15
<b>2.4</b>	<b>Starting up for the first time.....</b>	<b>2-17</b>
<b>2.5</b>	<b>Turning off the computer.....</b>	<b>2-17</b>

## Chapter 3: BIOS Setup

<b>3.1</b>	<b>Knowing BIOS.....</b>	<b>3-1</b>
<b>3.2</b>	<b>BIOS setup program.....</b>	<b>3-2</b>
3.2.1	EZ Mode.....	3-3
3.2.2	Advanced Mode.....	3-4
3.2.3	QFan Control.....	3-7
3.2.4	EZ Tuning Wizard.....	3-8

<b>3.3</b>	<b>My Favorites</b> .....	<b>3-10</b>
<b>3.4</b>	<b>Main menu</b> .....	<b>3-12</b>
<b>3.5</b>	<b>Ai Tweaker menu</b> .....	<b>3-12</b>
<b>3.6</b>	<b>Advanced menu</b> .....	<b>3-13</b>
	3.6.1 Trusted Computing.....	3-13
	3.6.2 AMD fTPM Configuration .....	3-13
	3.6.3 SATA Configuration .....	3-13
	3.6.4 Onboard Devices Configuration.....	3-14
	3.6.5 APM Configuration .....	3-15
	3.6.6 CPU Configuration .....	3-16
	3.6.7 Network Stack Configuration.....	3-16
	3.6.8 HDD/SSD SMART Information .....	3-16
	3.6.9 USB Configuration .....	3-16
	3.6.10 AMD PBS.....	3-17
<b>3.7</b>	<b>Monitor menu</b> .....	<b>3-17</b>
<b>3.8</b>	<b>Boot menu</b> .....	<b>3-18</b>
<b>3.9</b>	<b>Tool menu</b> .....	<b>3-19</b>
	3.9.1 ASUS EZ Flash 3 Utility .....	3-19
	3.9.2 Secure Erase .....	3-20
	3.9.3 ASUS Overclocking Profile .....	3-21
	3.9.4 ASUS SPD Information.....	3-21
	3.9.5 Graphics Card Information.....	3-21
<b>3.10</b>	<b>Exit menu</b> .....	<b>3-22</b>
<b>3.11</b>	<b>Updating BIOS</b> .....	<b>3-23</b>
	3.11.1 EZ Update.....	3-23
	3.11.2 ASUS EZ Flash 3.....	3-24
	3.11.3 ASUS CrashFree BIOS 3.....	3-26

## **Chapter 4: RAID Support**

<b>4.1</b>	<b>AMD RAID Array configurations</b> .....	<b>4-1</b>
	4.1.1 RAID definitions .....	4-1
	4.1.2 Installing storage devices.....	4-2
	4.1.3 RaidXpert2 Configuration Utility in UEFI BIOS .....	4-2
<b>4.2</b>	<b>Creating a RAID driver disk</b> .....	<b>4-5</b>
	4.2.1 Creating a RAID driver disk in Windows® .....	4-5

## **Appendix**

<b>Notices</b> .....	<b>A-1</b>
<b>ASUS contact information</b> .....	<b>A-5</b>

# Safety information

## Electrical safety

- To prevent electrical shock hazard, disconnect the power cable from the electrical outlet before relocating the system.
- When adding or removing devices to or from the system, ensure that the power cables for the devices are unplugged before the signal cables are connected. If possible, disconnect all power cables from the existing system before you add a device.
- Before connecting or removing signal cables from the motherboard, ensure that all power cables are unplugged.
- Seek professional assistance before using an adapter or extension cord. These devices could interrupt the grounding circuit.
- Ensure that your power supply is set to the correct voltage in your area. If you are not sure about the voltage of the electrical outlet you are using, contact your local power company.
- If the power supply is broken, do not try to fix it by yourself. Contact a qualified service technician or your retailer.

## Operation safety

- Before installing the motherboard and adding devices on it, carefully read all the manuals that came with the package.
- Before using the product, ensure all cables are correctly connected and the power cables are not damaged. If you detect any damage, contact your dealer immediately.
- To avoid short circuits, keep paper clips, screws, and staples away from connectors, slots, sockets and circuitry.
- Avoid dust, humidity, and temperature extremes. Do not place the product in any area where it may become wet.
- Place the product on a stable surface.
- If you encounter technical problems with the product, contact a qualified service technician or your retailer.

## About this guide

This user guide contains the information you need when installing and configuring the motherboard.

## How this guide is organized

This guide contains the following parts:

### 1. Chapter 1: Product Introduction

This chapter describes the features of the motherboard and the new technology it supports. It includes description of the switches, jumpers, and connectors on the motherboard.

### 2. Chapter 2: Basic Installation

This chapter lists the hardware setup procedures that you have to perform when installing system components.

### 3. Chapter 3: BIOS Setup

This chapter tells how to change system settings through the BIOS Setup menus. Detailed descriptions of the BIOS parameters are also provided.

### 4. Chapter 4: RAID Support

This chapter describes the RAID configurations.

## Where to find more information

Refer to the following sources for additional information and for product and software updates.

### 1. ASUS website

The ASUS website ([www.asus.com](http://www.asus.com)) provides updated information on ASUS hardware and software products.

### 2. Optional documentation

Your product package may include optional documentation, such as warranty flyers, that may have been added by your dealer. These documents are not part of the standard package.

## Conventions used in this guide

To ensure that you perform certain tasks properly, take note of the following symbols used throughout this manual.



**DANGER/WARNING:** Information to prevent injury to yourself when trying to complete a task.



**CAUTION:** Information to prevent damage to the components when trying to complete a task.



**IMPORTANT:** Instructions that you **MUST** follow to complete a task.



**NOTE:** Tips and additional information to help you complete a task.

## Typography

**Bold text**

Indicates a menu or an item to select.

*Italics*

Used to emphasize a word or a phrase.

<Key>

Keys enclosed in the less-than and greater-than sign means that you must press the enclosed key.

Example: <Enter> means that you must press the Enter or Return key.

<Key1> + <Key2> + <Key3>

If you must press two or more keys simultaneously, the key names are linked with a plus sign (+).

## PRIME X399-A specifications summary

<b>CPU</b>	AMD SocketTR4 socket for AMD Ryzen™ Threadripper™ processors * Refer to <a href="http://www.asus.com">www.asus.com</a> for the CPU support list.
<b>Chipset</b>	AMD X399
<b>Memory</b>	<b>AMD Ryzen™ Threadripper™ Processors</b> - 8 x DIMM, max. 128GB, DDR4 3600+(O.C.)/3466(O.C.)/3333(O.C.)/3200(O.C.)/3000(O.C.)/2800(O.C.)/2666/2400/2133 MHz, ECC and non-ECC, un-buffered memory - Quad channel memory architecture * Please refer to Memory QVL (Qualified Vendors List) for details.
<b>Expansion slots</b>	<b>AMD Ryzen™ Threadripper™ Processors</b> - 4 x PCIe 3.0 x16 slots (support x16/x8/x16/x8) <b>AMD X399 chipset</b> - 1 x PCIe 2.0 x4 slot - 1 x PCIe 2.0 x1 slot
<b>Multi-GPU support</b>	Supports NVIDIA® 3-Way/2-Way/Quad-GPU SLI™ Technology Supports AMD 3-Way/2-Way/Quad-GPU CrossFireX™ Technology
<b>Storage</b>	<b>AMD Ryzen™ Threadripper™ Processors*</b> - 1 x M.2_1 Socket 3 with M key, type 2242/2260/2280 storage devices support (both SATA & PCIE 3.0 x 4 mode) - 1 x M.2_2 Socket 3 with vertical M Key, type 2242/2260/2280/22110 storage devices support (both SATA & PCIE 3.0 x 4 mode) - 1 x U.2 port <b>AMD X399 chipset</b> - 6 x SATA 6Gb/s ports * Supports PCIe RAID configurations via onboard M.2 storages for up to 8 storage devices.
<b>LAN</b>	Intel® Ethernet Controller I211-AT ASUS LAN Guard ASUS Turbo LAN Utility
<b>USB</b>	<b>AMD Ryzen™ Threadripper™ Processors</b> - 8 x USB 3.1 Gen 1 ports (8 ports at back panel[blue]) <b>AMD X399 chipset:</b> - 1 x USB 3.1 Gen 2 front panel connector - 4 x USB 3.1 Gen 1 ports (4 ports at mid-board) - 4 x USB 2.0 ports (4 ports at mid-board) <b>ASMedia® 3142 USB 3.1 Gen 2 controller</b> - 2 x USB 3.1 Gen 2 ports (1 x Type-A and 1 x USB Type-C™, at back panel)

(continued on the next page)



# PRIME X399-A specifications summary

<b>Audio</b>	<p><b>Realtek® S1220A 8-channel high definition audio CODEC featuring Crystal Sound 3</b></p> <ul style="list-style-type: none"><li>- Power pre-regulator reduces power input noise to ensure consistent performance</li><li>- Separate layer for left and right track, ensuring both sound deliver equal quality</li><li>- Impedance sense for front and rear headphone outputs</li><li>- Audio shielding ensures precise analog/digital separation and greatly reduced multi-lateral interference</li><li>- EMI protection cover to prevent electrical noise to affect the amplifier quality</li><li>- Internal audio Amplifier to enhance the highest quality sound for headphone and speakers</li><li>- Unique de-pop circuit to reduce start-up popping noise to audio outputs</li><li>- Premium Japan-made audio capacitors provides warm, natural, and immersive sound with exceptional clarity and fidelity</li><li>- High quality 120dB SNR stereo playback output (Line-out@back) &amp; 113dB SNR input (Line-in) support</li><li>- Supports up to 32-Bit/192kHz playback*</li><li>- DTS® Headphone:X™</li><li>- DTS® Connect</li><li>- Supports jack-detection, multi-streaming, front panel jack-retasking (MIC)</li><li>- Optical S/PDIF out port at back I/O</li></ul> <p>* Due to limitations in HDA bandwidth, 32-Bit/192kHz is not supported for 8-Channel audio. 32-Bit/192kHz is only available under Windows® 10.</p>
<b>ASUS Exclusive Features</b>	<p><b>&lt;Performance&gt;</b></p> <p><b>OC Design: ASUS PRO Clock Technology</b></p> <ul style="list-style-type: none"><li>- Full BCLK range for extreme overclocking performance.</li></ul> <p><b>5-Way Optimization</b></p> <ul style="list-style-type: none"><li>- Whole system optimization with a single click! Perfectly consolidates better CPU performance, power saving, digital power control, system cooling and app usages.</li></ul> <p><b>DIGI+ Power Control</b></p> <ul style="list-style-type: none"><li>- CPU Power: Digital 8+3 phase power design</li><li>- DRAM Power: Digital 4-phase power design</li></ul> <p><b>TPU</b></p> <ul style="list-style-type: none"><li>- Auto Tuning, TPU</li></ul> <p><b>EPU</b></p> <p><b>Fan Xpert 4</b></p> <p><b>Turbo App</b></p> <p><b>UEFI BIOS</b></p> <ul style="list-style-type: none"><li><b>CrashFree BIOS 3</b></li><li><b>EZ Flash 3</b></li><li><b>EZ Tuning Wizard</b></li></ul>

(continued on the next page)

## PRIME X399-A specifications summary

<p><b>ASUS Exclusive Features</b></p>	<p>&lt;Gaming&gt;  <b>AURA SYNC</b>  <b>3D Printing Friendly design</b>  <b>Turbo LAN</b></p> <p>&lt;EZ Management&gt;  <b>File Transfer</b>  <b>PC Cleaner</b></p> <p>&lt;EZ DIY&gt;  <b>Q-Design</b>  - ASUS Q-Code  - ASUS Q-Connector  - ASUS Q-DIMM  - ASUS Q-LED (CPU, DRAM, VGA, Boot Device LED)  - ASUS Q-Shield  - ASUS Q-Slot</p>
<p><b>ASUS Special Features</b></p>	<p><b>ASUS SafeSlot</b>  - Protect your graphics card Investment</p> <p><b>ASUS 5X Protection III</b>  - ASUS SafeSlot Core - Fortified PCIe with solid soldering  - ASUS LANGuard - Protects against LAN surges, lightning strikes and static-electricity discharges!  - ASUS Overvoltage Protection - World-class circuit-protecting power design  - ASUS DIGI+ VRM - Digital power design  - ASUS DRAM Overcurrent Protection: Enhanced DRAM overcurrent protection  - ASUS Stainless-Steel Back I/O: 3X corrosion-resistance for greater durability!  - AI Suite 3  - Ai Charger</p>
<p><b>ASUS Quiet Thermal Solution</b></p>	<p><b>Quiet Thermal Design:</b>  - ASUS Fan Xpert 4  - ASUS Stylish MOS &amp; M.2 heatsink Design</p>
<p><b>Back Panel I/O Ports</b></p>	<p>1 x BIOS Flashback button  1 x Optical S/PDIF out  1 x Intel LAN (RJ45) port  2 x USB 3.1 Gen 2 ports (Type-A + USB Type-C™ [teal blue])  8 x USB 3.1 Gen 1 ports (blue)  5 x Audio jacks (Line in, Front Speaker Out, Mic in, Center/Subwoofer, Rear Speaker Out)</p>

*(continued on the next page)*

## PRIME X399-A specifications summary

<b>Internal I/O connectors</b>	<p>1 x USB 3.1 Gen 2 front panel connector</p> <p>2 x USB 3.0 Gen 1 connectors support additional 4 USB ports (19-pin)</p> <p>2 x USB 2.0 connectors support additional 4 USB ports</p> <p>1 x M.2_1 Socket 3 with M key, type 2242/2260/2280 storage devices support (both SATA &amp; PCIE 3.0 x 4 mode)</p> <p>1 x M.2_2 Socket 3 with vertical M Key, type 2242/2260/2280/22110 storage devices support (both SATA &amp; PCIE 3.0 x 4 mode)</p> <p>1 x U.2 port</p> <p>6 x SATA 6.0Gb/s connectors</p> <p>1 x 4-pin W_PUMP+ connector</p> <p>1 x 4-pin AIO_PUMP fan connector</p> <p>1 x 4-pin CPU fan connector</p> <p>1 x 4-pin CPU optional fan (CPU_OPT) connector</p> <p>1 x 3-pin Cover fan (COV_FAN) connector</p> <p>3 x 4-pin Chassis fan connectors</p> <p>1 x 4-pin M.2 fan connector</p> <p>1 x 5-pin Extension Fan (EXT_FAN) connector</p> <p>1 x 2-pin Thermal sensor header</p> <p>1 x 24-pin EATX Power connector</p> <p>1 x 8-pin EATX 12V Power connector</p> <p>1 x 4-pin EATX 12V Power connector</p> <p>2 x RGB headers</p> <p>1 x Front panel audio connector (AAFP)</p> <p>1 x System panel connector (Q-Connector)</p> <p>1 x Q_Code LED</p> <p>1 x Clear CMOS header</p> <p>1 x Power-on button</p>
<b>BIOS Features</b>	<p>128 Mb Flash ROM, UEFI AMI BIOS, PnP, WfM2.0, SM BIOS 3.0, ACPI 6.1, Multi-language BIOS, ASUS EZ Flash 3, CrashFree BIOS 3, F11 EZ Tuning Wizard, F6 Qfan Control, F3 My Favorites, Last Modified log, F12 PrintScreen, and ASUS DRAM SPD (Serial Presence Detect) memory information</p>
<b>Manageability</b>	<p>WfM 2.0, DMI 3.0, WOL by PME, PXE</p>
<b>Support DVD contents</b>	<p>Drivers</p> <p>ASUS Utilities</p> <p>EZ Update</p> <p>Anti-virus software (OEM version)</p>
<b>Operating system support</b>	<p>Windows® 10 64-bit</p>
<b>Form factor</b>	<p>Extended ATX Form Factor, 12"x 10.6" (30.5 cm x 26.9 cm)</p>



- Specifications are subject to change without notice.
- Visit the ASUS website for the software manual.

## Package contents





Check your motherboard package for the following items.

Motherboard	ASUS PRIME X399-A motherboard
Cables	4 x Serial ATA 6.0 Gb/s cables
	1 x ASUS SLI HB BRIDGE (2-WAY-M)
Accessories	1 x Q-Connector
	1 x M.2 vertical bracket
	1 x M.2 screw package
	1 x ASUS Q-Shield
Application DVD	Motherboard support DVD
Documentation	User manual

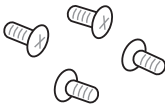

If any of the above items is damaged or missing, contact your retailer.

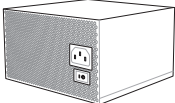
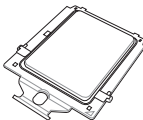
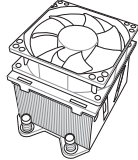
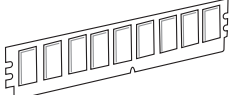
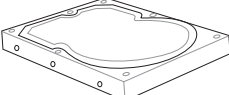
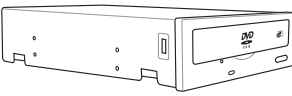
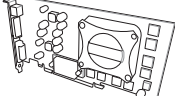
# Installation tools and components

	
<b>1 Bag of screws</b>	<b>Phillips (cross) screwdriver</b>
	
<b>PC chassis</b>	<b>Power supply unit</b>
	
<b>AMD SocketTR4 CPU</b>	<b>AMD SocketTR4 compatible CPU Fan</b>
	
<b>DDR4 DIMM</b>	<b>SATA hard disk drive</b>
	
<b>SATA optical disc drive (optional)</b>	<b>Graphics card</b>
	
<b>M.2 SSD module (optional)</b>	



The tools and components in the table above are not included in the motherboard package.



# Product Introduction

# 1

## 1.1 Motherboard overview

### 1.1.1 Before you proceed

Take note of the following precautions before you install motherboard components or change any motherboard settings.



- 
- Unplug the power cord from the wall socket before touching any component.
  - Before handling components, use a grounded wrist strap or touch a safely grounded object or a metal object, such as the power supply case, to avoid damaging them due to static electricity.
  - Hold components by the edges to avoid touching the ICs on them.
  - Whenever you uninstall any component, place it on a grounded antistatic pad or in the bag that came with the component.
  - Before you install or remove any component, ensure that the ATX power supply is switched off or the power cord is detached from the power supply. Failure to do so may cause severe damage to the motherboard, peripherals, or components.
-

# 1.1.2 Motherboard layout

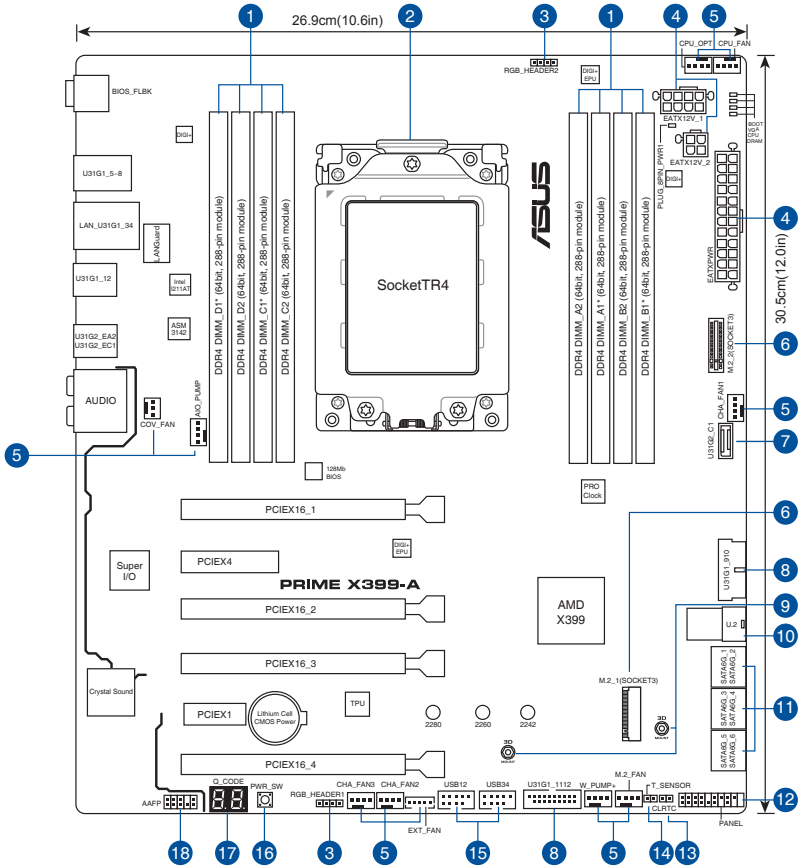

Refer to [1.1.8 Internal connectors](#) and [2.3.1 Rear I/O connection](#) for more information about rear panel connectors and internal connectors.



## Layout contents

Connectors/Jumpers/Buttons and switches/Slots		Page
1.	DDR4 DIMM slots	1-5
2.	SocketTR4 CPU socket	1-4
3.	RGB header (4-pin RGB_HEADER1-2)	1-25
4.	ATX power connectors (24-pin EATXPWR; 8-pin EATX12V_1; 4-pin EATX12V_2)	1-22
5.	CPU, CPU optional, cover, AIO pump, water pump+, extension, M.2, and chassis fan connectors (4-pin CPU_FAN; 4-pin CPU_OPT; 3-pin COV_FAN; 4-pin AIO_PUMP; 4-pin W_PUMP+; 4-pin M.2_FAN; 5-pin EXT_FAN; 4-pin CHA_FAN1-3)	1-21
6.	M.2 sockets [M.2_1(Socket 3); M.2_2(Socket 3)]	1-24
7.	USB 3.1 Gen 2 front panel connector (U31G2_C1)	1-18
8.	USB 3.1 Gen 1 connectors (20-1 pin U31G1_910; U31G1_1112)	1-19
9.	3D Mount holes	1-10
10.	U.2 connector (U.2)	1-24
11.	AMD Serial ATA 6.0 Gb/s connectors (7-pin SATA6G_1-6)	1-17
12.	System panel connector (20-5 pin PANEL)	1-23
13.	Clear RTC RAM jumper (2-pin CLRTC)	1-9
14.	Thermal sensor connector (2-pin T_SENSOR)	1-20
15.	USB 2.0 connectors (10-1 pin USB12; USB34)	1-20
16.	Power-on button	1-10
17.	Q-Code LED	1-11
18.	Front panel audio connector (10-1 pin AAFP)	1-18

### 1.1.3 Central Processing Unit (CPU)

The motherboard comes with a SocketTR4 socket designed for the AMD Ryzen™ Threadripper™ processors.

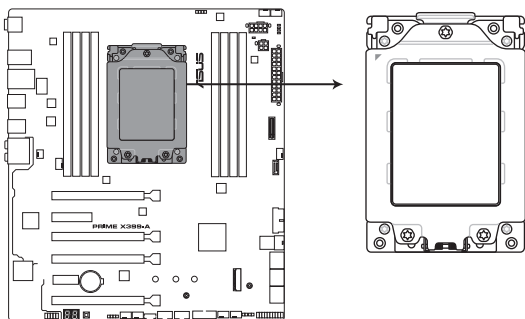

**PRIME X399-A CPU SocketTR4**



---

The SocketTR4 socket has a different pinout design. Ensure that you use a CPU designed for the SocketTR4 socket. The CPU fits in only one correct orientation. **DO NOT** force the CPU into the socket to prevent bending the connectors on the socket and damaging the CPU!

---



---

Ensure that all power cables are unplugged before installing the CPU.

---

## 1.1.4 System memory

The motherboard comes with eight DDR4 (Double Data Rate 4) Dual Inline Memory Modules (DIMM) slots.



A DDR4 module is notched differently from a DDR, DDR2, or DDR3 module. DO NOT install a DDR, DDR2, or DDR3 memory module to the DDR4 slot.

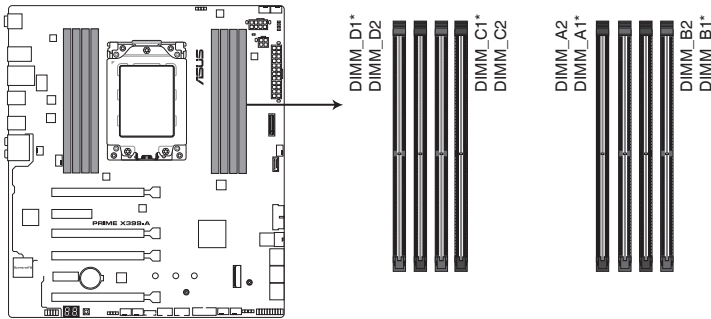

PRIME X399-A 288-pin DDR4 DIMM sockets

### Recommended memory configurations

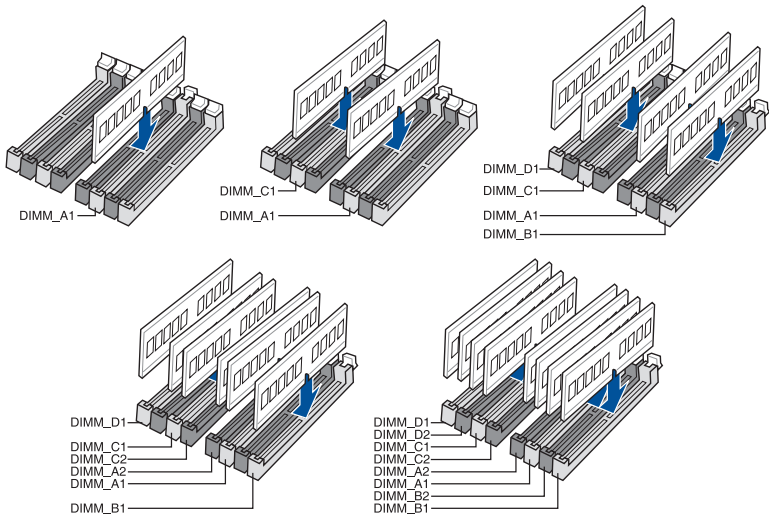

## Memory configurations

You may install 2 GB, 4 GB, 8 GB and 16 GB unbuffered ECC and non-ECC DDR4 DIMMs into the DIMM sockets.



- 
- You may install varying memory sizes in Channel A, Channel B, Channel C, and Channel D. The system maps the total size of the lower-sized channel for the quad channel configuration. Any excess memory from the higher-sized channel is then mapped for single-channel operation.
  - This motherboard does not support DIMMs made up of 512 Mb (64 MB) chips or less (Memory chip capacity counts in Megabit, 8 Megabit/Mb = 1 Megabyte/MB).
- 



- 
- The default memory operation frequency is dependent on its Serial Presence Detect (SPD), which is the standard way of accessing information from a memory module. Under the default state, some memory modules for overclocking may operate at a lower frequency than the vendor-marked value.
  - For system stability, use a more efficient memory cooling system to support a full memory load (8 DIMMs) or overclocking condition.
  - Always install the DIMMS with the same CAS Latency. For an optimum compatibility, we recommend that you install memory modules of the same version or data code (D/C) from the same vendor. Check with the vendor to get the correct memory modules.
  - Visit the ASUS website for the latest QVL.
-

## 1.1.5 Expansion slots



Unplug the power cord before adding or removing expansion cards. Failure to do so may cause you physical injury and damage motherboard components.

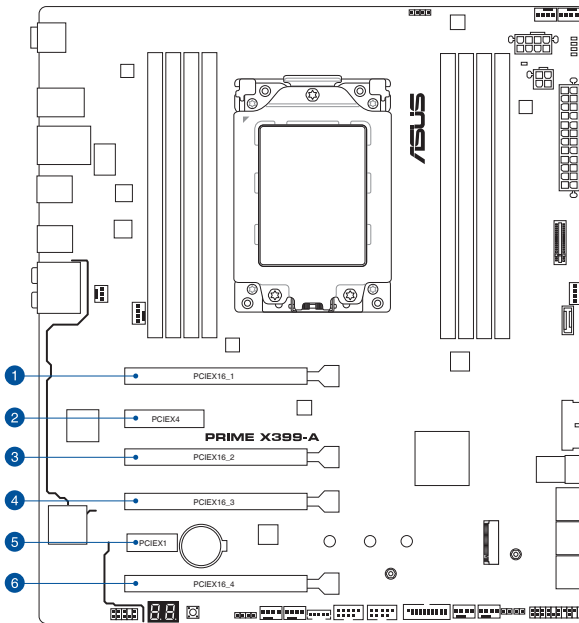

Slot No.	Slot Description
1	PCIe 3.0/2.0 x16_1 slot
2	PCIe 2.0 x4 slot
3	PCIe 3.0/2.0 x16_2 slot
4	PCIe 3.0/2.0 x16_3 slot
5	PCIe 2.0 x1 slot
6	PCIe 3.0/2.0 x16_4 slot

## AMD Ryzen™ Threadripper™ Processors

VGA Configuration	PCI Express 3.0 operating mode		
	Single VGA	SLI™/CFX	3-Way SLI™/CFX
PCIe x16_1	x16	x16	x16
PCIe x16_2	N/A	N/A	N/A
PCIe x16_3	N/A	x16	x16
PCIe x16_4	N/A	N/A	x8



- We recommend that you provide sufficient power when running CrossFireX™ or SLI™ mode.
- Connect chassis fans to the motherboard chassis fan connectors when using multiple graphics cards for better thermal environment.

## 1.1.6 Jumpers, buttons and holes

### 1. Clear RTC RAM jumper (2-pin CLRRTC)

This jumper allows you to clear the Real Time Clock (RTC) RAM in CMOS. You can clear the CMOS memory of date, time, and system setup parameters by erasing the CMOS RTC RAM data. The onboard button cell battery powers the RAM data in CMOS, which include system setup information such as system passwords.

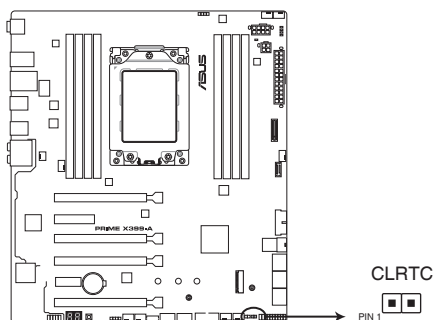

**PRIME X399-A Clear RTC RAM**

To erase the RTC RAM:

1. Turn OFF the computer and unplug the power cord.
2. Short-circuit pin 1-2 with a metal object or jumper cap for about 5-10 seconds.
3. Plug the power cord and turn ON the computer.
4. Hold down the <Delete> key during the boot process and enter BIOS setup to re-enter data.



Except when clearing the RTC RAM, never place a metal object or jumper cap on the CLRRTC jumper. Placing a metal object or jumper cap will cause system boot failure!



- If the steps above do not help, remove the onboard battery and place a metal object or jumper cap again to clear the CMOS RTC RAM data. After the CMOS clearance, reinstall the battery.
- You do not need to clear the RTC when the system hangs due to overclocking. For system failure due to overclocking, use the C.P.R. (CPU Parameter Recall) feature. Shut down and reboot the system so the BIOS can automatically reset parameter settings to default values.
- Due to the chipset behavior, AC power off is required to enable C.P.R. function. You must turn off and turn on the power supply or unplug and plug the power cord before rebooting the system.

## 2. Power-on button

The motherboard comes with a power-on button that allows you to power up or wake up the system. The button also lights up when the system is plugged to a power source indicating that you should shut down the system and unplug the power cable before removing or installing any motherboard component.

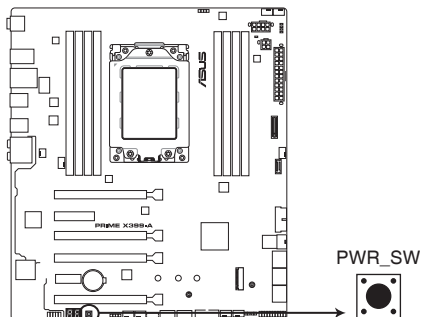

**PRIME X399-A Power-on button**

## 3. 3D Mount holes

Secure 3D printed parts to these 3D Mount holes for a personalized motherboard.

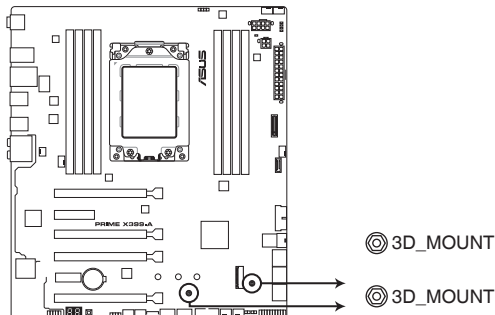

**PRIME X399-A 3D Mount holes**



For more details regarding the installation of the 3D printing part on your motherboard, please refer to the product page of your motherboard on the ASUS website at <http://www.asus.com>.



## 1.1.7 Onboard LEDs

### 1. POST State LEDs

The POST State LEDs provide the status of these key components during POST (Power-On Self-Test): CPU, memory modules, VGA card, and hard disk drives. If an error is found, the critical component's LED stays lit up until the problem is solved.

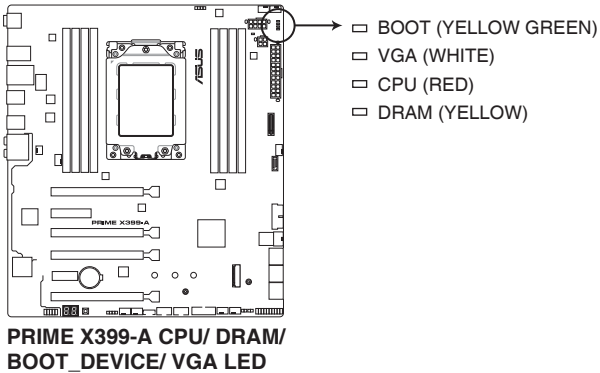

### 2. Q-Code LED

The Q-Code LED design provides you with a 2-digit error code that displays the system status. Refer to the Q-Code table on the next page for details.

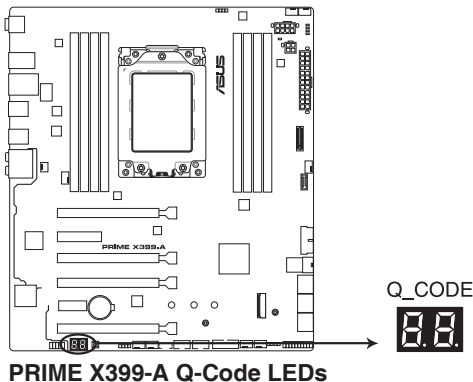

## Q-Code table

Code	Description
00	Not used
01	Power on. Reset type detection (soft/hard).
02	AP initialization before microcode loading
03	System Agent initialization before microcode loading
04	PCH initialization before microcode loading
06	Microcode loading
07	AP initialization after microcode loading
08	System Agent initialization after microcode loading
09	PCH initialization after microcode loading
0B	Cache initialization
0C – 0D	Reserved for future AMI SEC error codes
0E	Microcode not found
0F	Microcode not loaded
10	PEI Core is started
11 – 14	Pre-memory CPU initialization is started
15 – 18	Pre-memory System Agent initialization is started
19 – 1C	Pre-memory PCH initialization is started
2B – 2F	Memory initialization
30	Reserved for ASL (see ASL Status Codes section below)
31	Memory Installed
32 – 36	CPU post-memory initialization
37 – 3A	Post-Memory System Agent initialization is started
3B – 3E	Post-Memory PCH initialization is started
4F	DXE IPL is started
50 – 53	Memory initialization error. Invalid memory type or incompatible memory speed
54	Unspecified memory initialization error
55	Memory not installed
56	Invalid CPU type or Speed
57	CPU mismatch
58	CPU self test failed or possible CPU cache error
59	CPU micro-code is not found or micro-code update is failed

(continued on the next page)

## Q-Code table

Code	Description
5A	Internal CPU error
5B	Reset PPI is not available
5C – 5F	Reserved for future AMI error codes
E0	S3 Resume is started (S3 Resume PPI is called by the DXE IPL)
E1	S3 Boot Script execution
E2	Video repost
E3	OS S3 wake vector call
E4 – E7	Reserved for future AMI progress codes
E8	S3 Resume Failed
E9	S3 Resume PPI not Found
EA	S3 Resume Boot Script Error
EB	S3 OS Wake Error
EC – EF	Reserved for future AMI error codes
F0	Recovery condition triggered by firmware (Auto recovery)
F1	Recovery condition triggered by user (Forced recovery)
F2	Recovery process started
F3	Recovery firmware image is found
F4	Recovery firmware image is loaded
F5 – F7	Reserved for future AMI progress codes
F8	Recovery PPI is not available
F9	Recovery capsule is not found
FA	Invalid recovery capsule
FB – FF	Reserved for future AMI error codes
60	DXE Core is started
61	NVRAM initialization
62	Installation of the PCH Runtime Services
63 – 67	CPU DXE initialization is started
68	PCI host bridge initialization
69	System Agent DXE initialization is started
6A	System Agent DXE SMM initialization is started
6B – 6F	System Agent DXE initialization (System Agent module specific)

(continued on the next page)

## Q-Code table

Code	Description
70	PCH DXE initialization is started
71	PCH DXE SMM initialization is started
72	PCH devices initialization
73 – 77	PCH DXE Initialization (PCH module specific)
78	ACPI module initialization
79	CSM initialization
7A – 7F	Reserved for future AMI DXE codes
90	Boot Device Selection (BDS) phase is started
91	Driver connecting is started
92	PCI Bus initialization is started
93	PCI Bus Hot Plug Controller Initialization
94	PCI Bus Enumeration
95	PCI Bus Request Resources
96	PCI Bus Assign Resources
97	Console Output devices connect
98	Console input devices connect
99	Super IO Initialization
9A	USB initialization is started
9B	USB Reset
9C	USB Detect
9D	USB Enable
9E – 9F	Reserved for future AMI codes
A0	IDE initialization is started
A1	IDE Reset
A2	IDE Detect
A3	IDE Enable
A4	SCSI initialization is started
A5	SCSI Reset
A6	SCSI Detect
A7	SCSI Enable
A8	Setup Verifying Password

*(continued on the next page)*

## Q-Code table

Code	Description
A9	Start of Setup
AA	Reserved for ASL (see ASL Status Codes section below)
AB	Setup Input Wait
AC	Reserved for ASL (see ASL Status Codes section below)
AD	Ready To Boot event
AE	Legacy Boot event
AF	Exit Boot Services event
B0	Runtime Set Virtual Address MAP Begin
B1	Runtime Set Virtual Address MAP End
B2	Legacy Option ROM Initialization
B3	System Reset
B4	USB hot plug
B6	Clean-up of NVRAM
B7	Configuration Reset (reset of NVRAM settings)
B8– BF	Reserved for future AML codes
D0	CPU initialization error
D1	System Agent initialization error
D2	PCH initialization error
D3	Some of the Architectural Protocols are not available
D4	PCI resource allocation error. Out of Resources
D5	No Space for Legacy Option ROM
D6	No Console Output Devices are found
D7	No Console Input Devices are found
D8	Invalid password
D9	Error loading Boot Option (LoadImage returned error)
DA	Boot Option is failed (StartImage returned error)
DB	Flash update is failed
DC	Reset protocol is not available
B5	PCI bus hot plug

## ACPI/ASL Checkpoints

Code	Description
0x01	System is entering S1 sleep state
0x02	System is entering S2 sleep state
0x03	System is entering S3 sleep state
0x04	System is entering S4 sleep state
0x05	System is entering S5 sleep state
0x10	System is waking up from the S1 sleep state
0x20	System is waking up from the S2 sleep state
0x30	System is waking up from the S3 sleep state
0x40	System is waking up from the S4 sleep state
0xAC	System has transitioned into ACPI mode. Interrupt controller is in PIC mode.
0xAA	System has transitioned into ACPI mode. Interrupt controller is in APIC mode.

## 1.1.8 Internal connectors

### 1. AMD Serial ATA 6.0 Gb/s connectors (7-pin SATA6G\_1-6)

These connectors connect to Serial ATA 6.0 Gb/s hard disk drives via Serial ATA 6.0 Gb/s signal cables.

If you installed Serial ATA hard disk drives, you can create a RAID 0, 1, and 10 configuration through the onboard AMD X399 chipset.

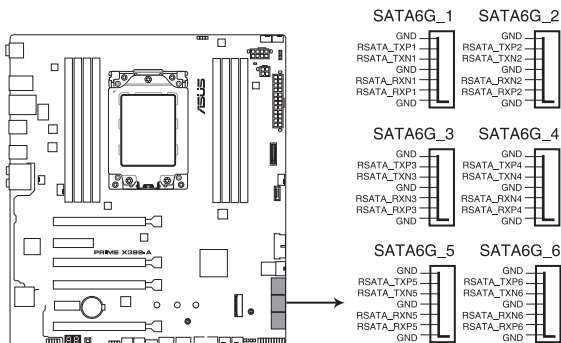

**PRIME X399-A Serial ATA 6.0Gb/s connectors**

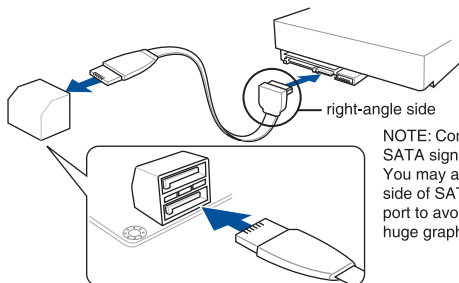

**NOTE:** Connect the right-angle side of SATA signal cable to SATA device. You may also connect the right-angle side of SATA cable to the onboard SATA port to avoid mechanical conflict with huge graphics cards.



These connectors are set to **[AHCI]** by default. If you intend to create a Serial ATA RAID set using these connectors, set the SATA Mode Selection item in the BIOS to **[RAID]**.

## 2. Front panel audio connector (10-1 pin AAFP)

This connector is for a chassis-mounted front panel audio I/O module that supports HD Audio. Connect one end of the front panel audio I/O module cable to this connector.

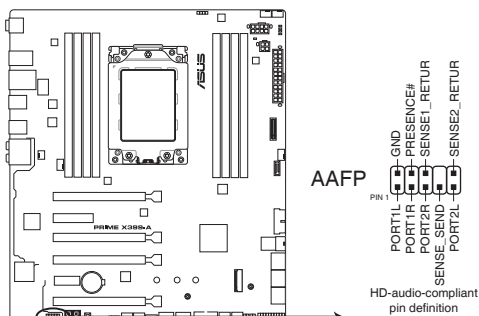

**PRIME X399-A Front panel audio connector**



We recommend that you connect a high-definition front panel audio module to this connector to avail of the motherboard's high-definition audio capability.

## 3. USB 3.1 Gen 2 front panel connector (U31G2\_C1)

This connector allows you to connect a USB 3.1 Gen 2 module for additional USB 3.1 Gen 2 ports. The latest USB 3.1 Gen 2 connectivity provides data transfer speeds of up to 10 Gbps.

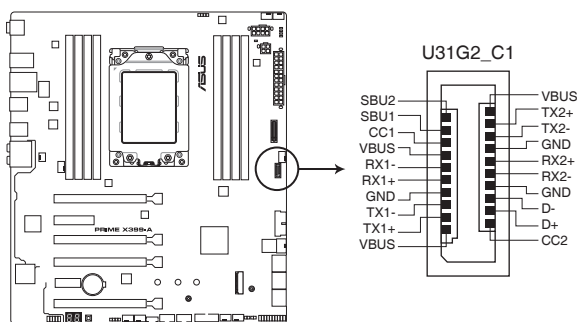

**PRIME X399-A USB 3.1 Gen 2 front panel connector**



#### 4. USB 3.1 Gen 1 connectors (20-pin U31G1\_910; U31G1\_1112)

These connectors allow you to connect a USB 3.1 Gen 1 module for additional USB 3.1 Gen 1 front or rear panel ports. With an installed USB 3.1 Gen 1 module, you can enjoy all the benefits of USB 3.1 Gen 1 including faster data transfer speeds of up to 5 Gb/s, faster charging time for USB-chargable devices, optimized power efficiency, and backward compatibility with USB 2.0.

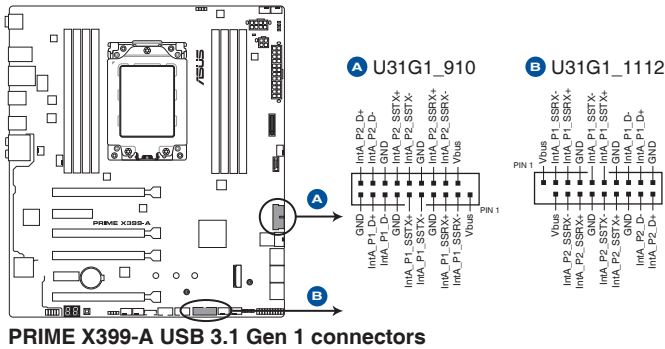

The USB 3.1 Gen 1 module is purchased separately.



The plugged USB 3.1 Gen 1 device may run on xHCI or EHCI mode depending on the operating system's setting.

## 5. USB 2.0 connectors (10-1 pin USB12; USB34)

These connectors are for USB 2.0 ports. Connect the USB module cable to any of these connectors, then install the module to a slot opening at the back of the system chassis. These USB connectors comply with USB 2.0 specification that supports up to 480 Mb/s connection speed.

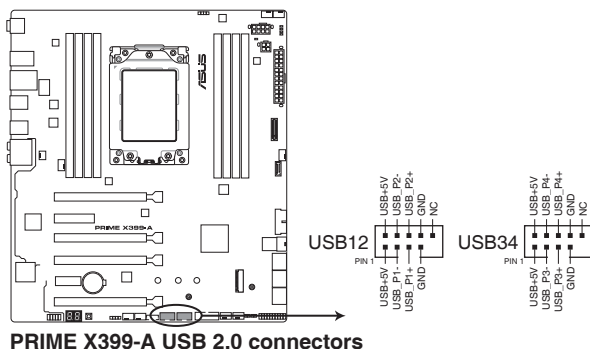

## 6. Thermal sensor connector (2-pin T\_SENSOR)

This connector is for the thermistor cable that monitors the temperature of the devices and the critical components inside the motherboard. Connect the thermistor cable and place the sensor on the device or the motherboard's component to detect its temperature.

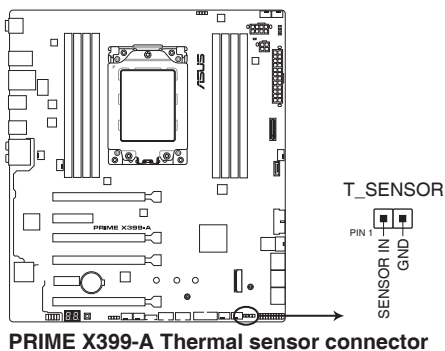

7. CPU, CPU optional, cover, AIO pump, water pump+, extension, M.2, and chassis fan connectors (4-pin CPU\_FAN; 4-pin CPU\_OPT; 3-pin COV\_FAN; 4-pin AIO\_PUMP; 4-pin W\_PUMP+; 4-pin M.2\_FAN; 5-pin EXT\_FAN; 4-pin CHA\_FAN1-3)

Connect the fan cables to the fan connectors on the motherboard, ensuring that the black wire of each cable matches the ground pin of the connector.

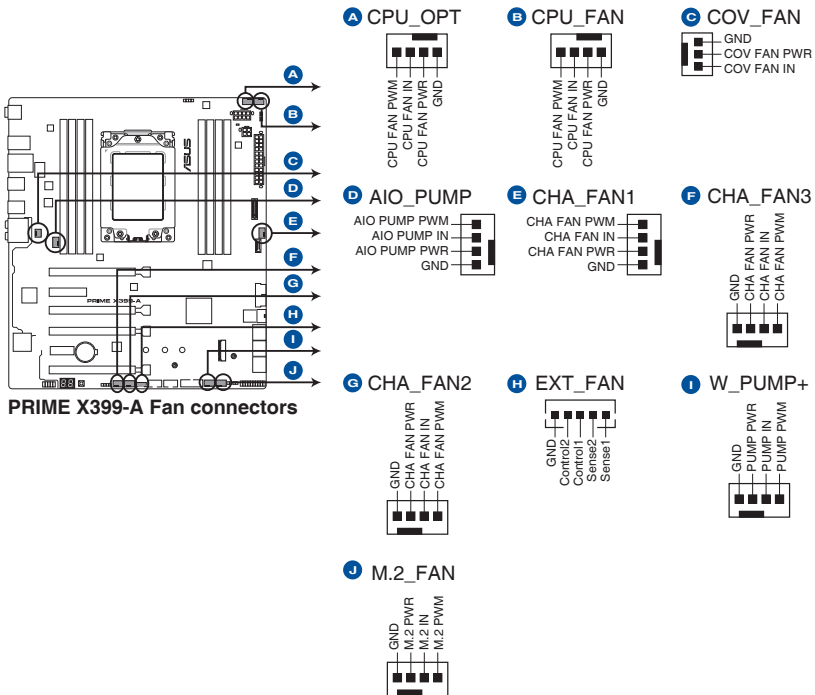

- DO NOT forget to connect the fan cables to the fan connectors. Insufficient air flow inside the system may damage the motherboard components. These are not jumpers! Do not place jumper caps on the fan connectors!
- Ensure that the CPU fan cable is securely installed to the CPU fan connector.



- The CPU\_FAN connector supports the CPU fan of maximum 1A (12 W) fan power.
- W\_PUMP+ function support depends on water cooling device.
- Connect the fan of your water cooling kit to the AIO\_PUMP connector.

## 8. ATX power connectors (24-pin EATXPWR; 8-pin EATX12V\_1; 4-pin EATX12V\_2)

These connectors are for ATX power supply plugs. The power supply plugs are designed to fit these connectors in only one orientation. Find the proper orientation and push down firmly until the connectors completely fit.

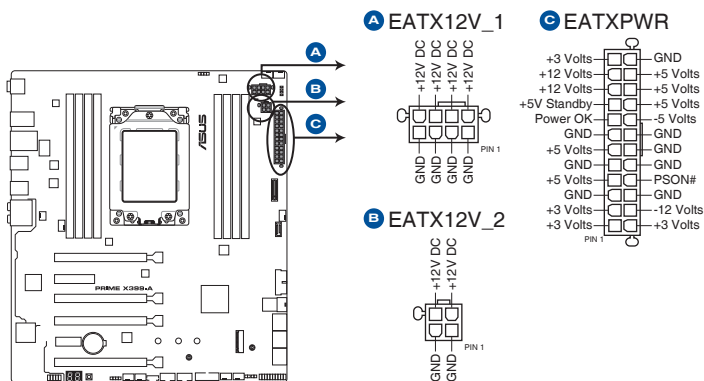

**PRIME X399-A ATX power connectors**



- DO NOT connect the 4-pin power plug only, the motherboard may overheat under heavy usage.
- Ensure to connect the 8-pin power plug, or connect both the 8-pin and 4-pin power plugs.



- For a fully configured system, we recommend that you use a power supply unit (PSU) that complies with ATX 12V Specification 2.0 (or later version) and provides a minimum power of 30A.
- We recommend that you use a PSU with a higher power output when configuring a system with more power-consuming devices. The system may become unstable or may not boot up if the power is inadequate.
- If you want to use two or more high-end PCI Express x16 cards, use a PSU with 1000W power or above to ensure the system stability.

## 9. System panel connector (20-5 pin PANEL)

This connector supports several chassis-mounted functions.

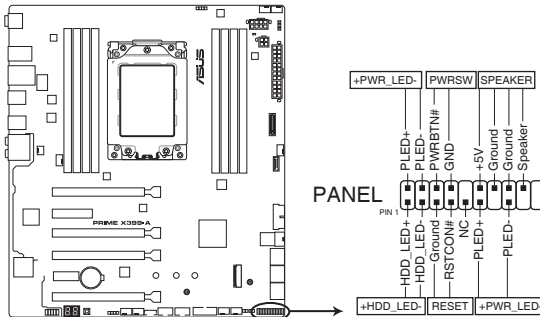

**PRIME X399-A System panel connector**

- **System power LED (2-pin or 3-1 pin PWR\_LED)**

The 2-pin or 3-1 pin connector is for the system power LED. Connect the chassis power LED cable to this connector. The system power LED lights up when you turn on the system power, and blinks when the system is in sleep mode.

- **Hard disk drive activity LED (2-pin HDD\_LED)**

This 2-pin connector is for the HDD Activity LED. Connect the HDD Activity LED cable to this connector. The HDD LED lights up or flashes when data is read from or written to the HDD.

- **System warning speaker (4-pin SPEAKER)**

This 4-pin connector is for the chassis-mounted system warning speaker. The speaker allows you to hear system beeps and warnings.

- **ATX power button/soft-off button (2-pin PWRSW)**

This connector is for the system power button. Pressing the power button turns the system on or puts the system in sleep or soft-off mode depending on the operating system settings. Pressing the power switch for more than four seconds while the system is ON turns the system OFF.

- **Reset button (2-pin RESET)**

This 2-pin connector is for the chassis-mounted reset button for system reboot without turning off the system power.

## 10. M.2 sockets [M.2\_1(Socket 3); M.2\_2(Socket 3)]

These sockets allow you to install M.2 SSD modules.

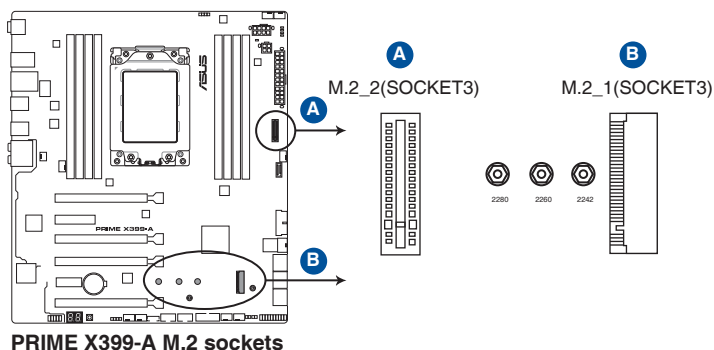

- M.2\_1 socket supports PCIe 3.0 x4 and SATA mode M Key design and type 2242 / 2260 / 2280 PCIe and SATA storage devices.
- M.2\_2 socket supports PCIe 3.0 x4 and SATA mode vertical M Key design and type 2242 / 2260 / 2280 / 22110 PCIe storage devices.



The M.2 SSD module is purchased separately.

## 11. U.2 connector (U.2)

This motherboard comes with a U.2 connector which supports PCIe 3.0 x4 NVM Express storage devices.

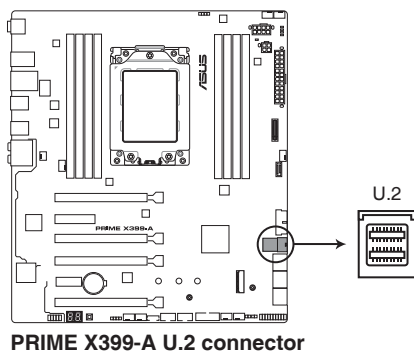

## 12. AURA RGB headers (4-pin RGB\_HEADER1-2)

These connectors are for RGB LED strips.

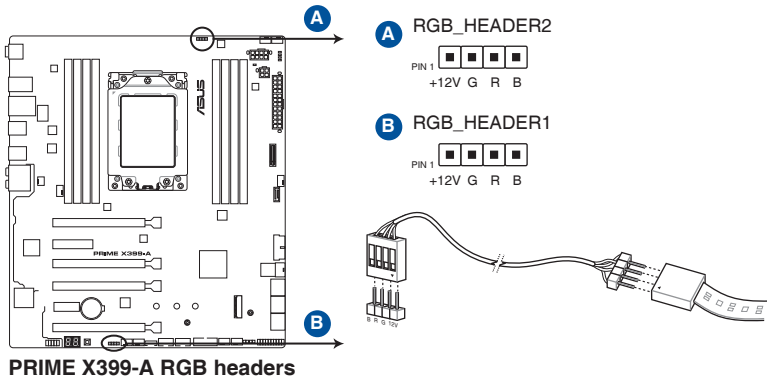

These RGB headers support 5050 RGB multi-color LED strips (12V/G/R/B), with a maximum power rating of 2A (12V), and no longer than 2 m.



Before you install or remove any component, ensure that the ATX power supply is switched off or the power cord is detached from the power supply. Failure to do so may cause severe damage to the motherboard, peripherals, or components.



- Actual lighting and color will vary with LED strip.
- If your LED strip does not light up, check if the RGB LED extension cable and the RGB LED strip is connected in the correct orientation, and the 12V connector is aligned with the 12V header on the motherboard.
- The LED strip will only light up under the operating system.
- The LED strip is purchased separately.





# Basic Installation

# 2

## 2.1 Building your PC system



The diagrams in this section are for reference only. The motherboard layout may vary with models, but the installation steps are the same for all models.

### 2.1.1 CPU installation



Unplug all power cables before installing the CPU.



The AMD SocketTR4 socket is compatible with AMD SocketTR4 processors. Ensure you use a CPU designed for the SocketTR4 socket. The CPU fits in only one correct orientation. **DO NOT** force the CPU into the socket to prevent bending the connectors on the socket and damaging the CPU!

- 1 Use the bundled Torx screwdriver to remove the load plate screws in sequence 3>2>1, then lift the load plate.

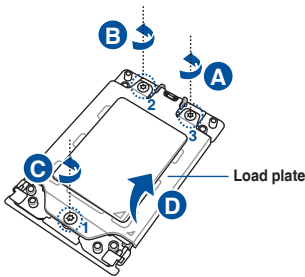

- 2 Use your fingers to pull up the tabs on both sides of the rail frame to release the rail frame, then lift the rail frame to its fully open position.

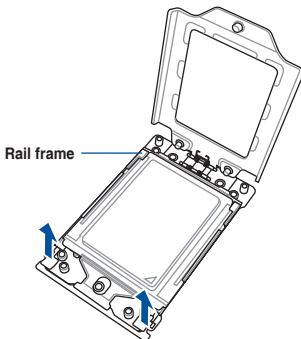

- 3 Remove the external cap.

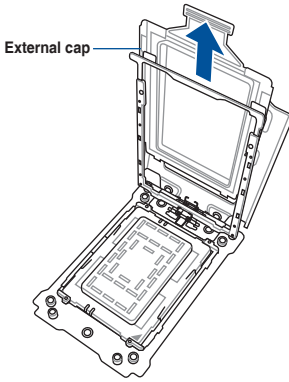

- 4 Slide the carrier frame with CPU into the rail frame until you hear a click sound, then remove the PnP cap.

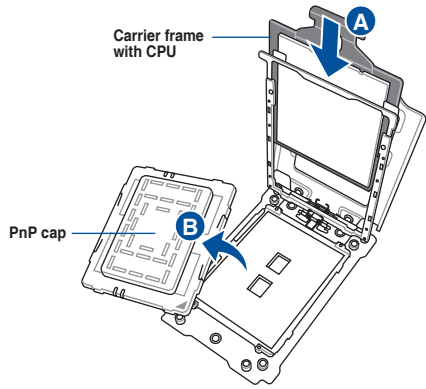

- 5 Gently press down the rail frame until it latches to the socket housing, then press down the load plate.

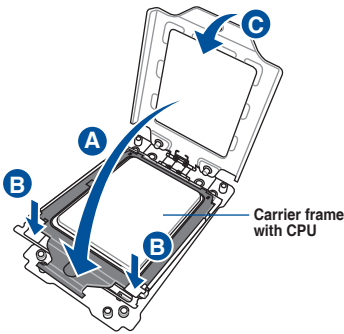

- 6 Drive the three screws slightly into the holes in sequence 1>2>3, just enough to attach the load plate to the socket. When the three screws are attached, tighten them in sequence 1>2>3 to completely secure the load plate. Then apply the Thermal Interface Material to the CPU.

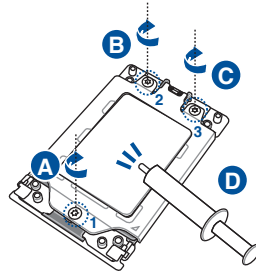

The load plate screws are Torx T20 models. A torque value of 14 inch-lbf is recommended.



Apply the Thermal Interface Material to the CPU heatsink and CPU before you install the heatsink and fan if necessary.

## 2.1.2 CPU heatsink and fan assembly installation

To install the CPU heatsink and fan assembly:

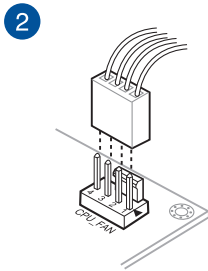
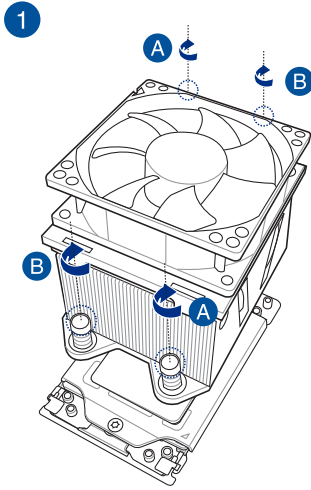

## 2.1.3 Motherboard installation

1. Install the ASUS Q-Shield to the chassis rear I/O panel.

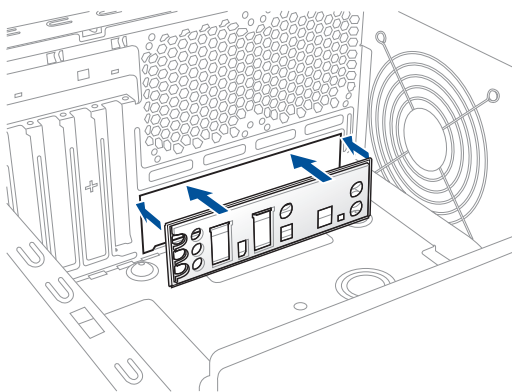

2. Place the motherboard into the chassis, ensuring that its rear I/O ports are aligned to the chassis' rear I/O panel.

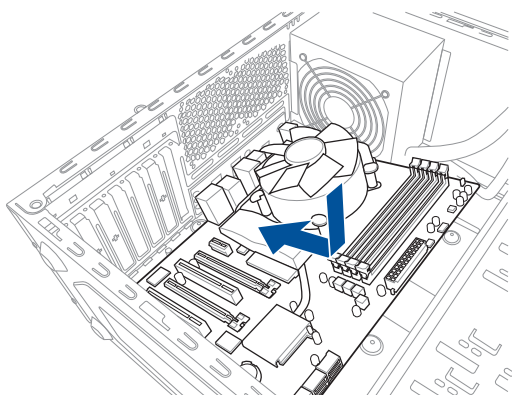

3. Place nine screws into the holes indicated by circles to secure the motherboard to the chassis.

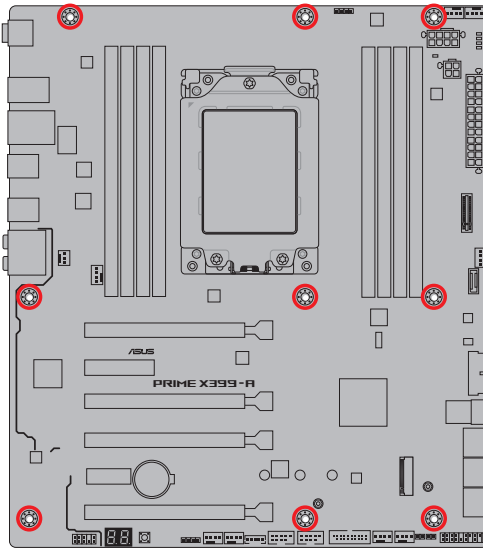
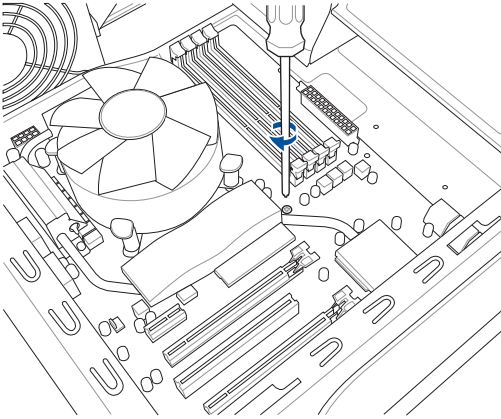

DO NOT overtighten the screws! Doing so can damage the motherboard.

## 2.1.4 DIMM installation

1

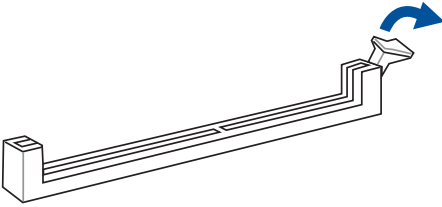

2

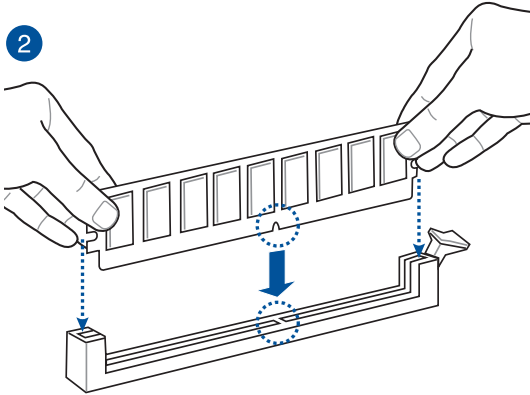

3

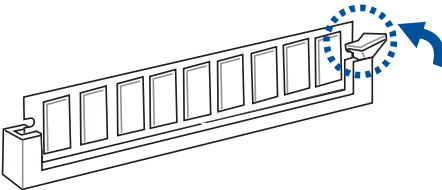

To remove a DIMM

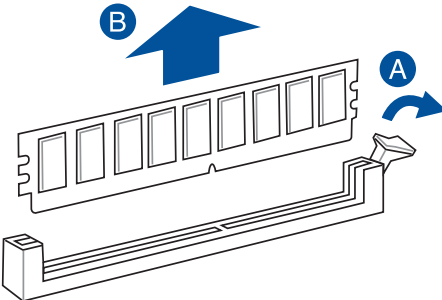

## 2.1.5 ATX power connection

1

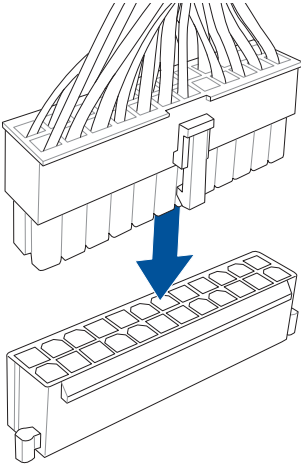

2

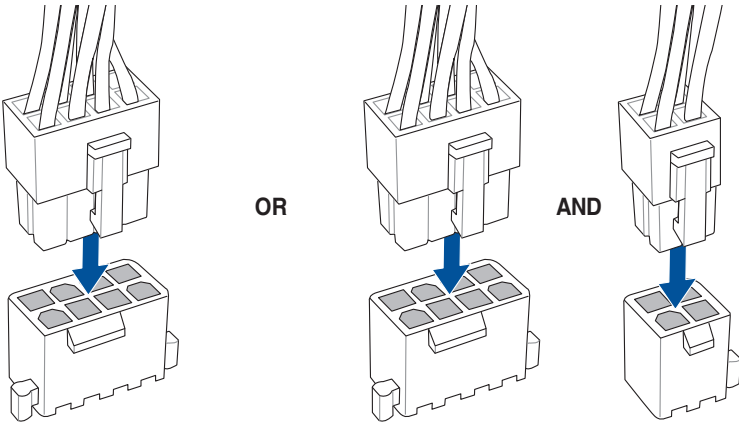

- DO NOT connect the 4-pin power plug only, the motherboard may overheat under heavy usage.
- Ensure to connect the 8-pin power plug, or connect both the 8-pin and 4-pin power plugs.

## 2.1.6 SATA device connection

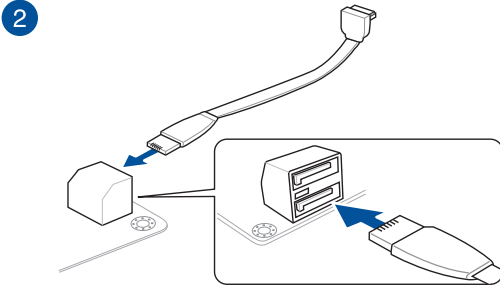
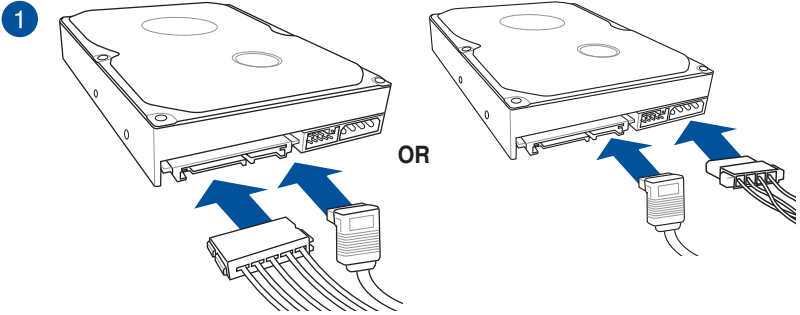



## 2.1.7 Front I/O connector

### To install ASUS Q-Connector

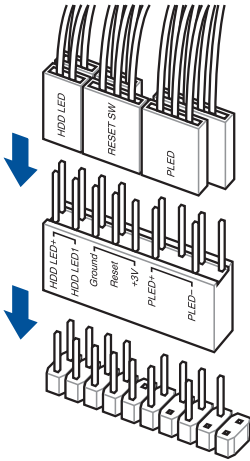

### To install USB 3.1 Gen 2 connector

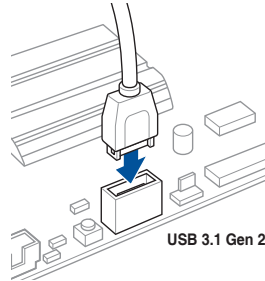

This connector will only fit in one orientation. Push the connector until it clicks into place.

### To install USB 3.1 Gen 1 connector

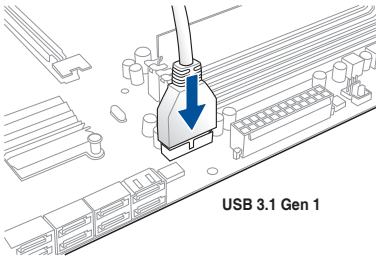

### To install USB 2.0 connector

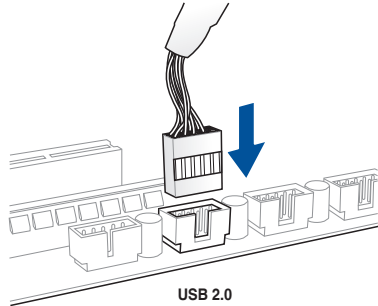

### To install front panel audio connector

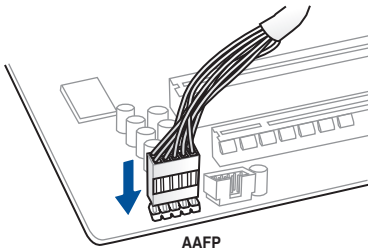

## 2.1.8 Expansion card installation

To install PCIe x16 cards

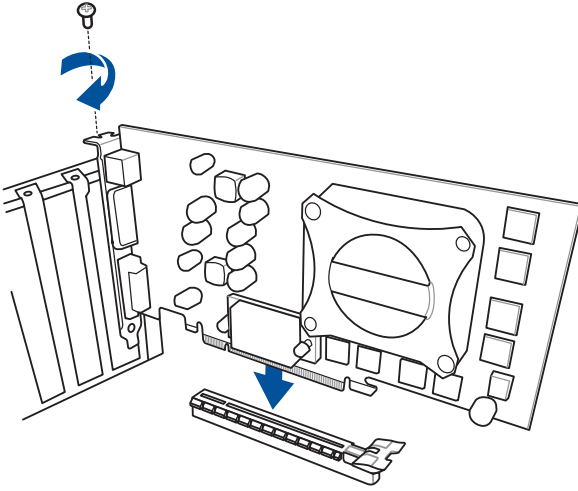

To install PCIe x1 cards

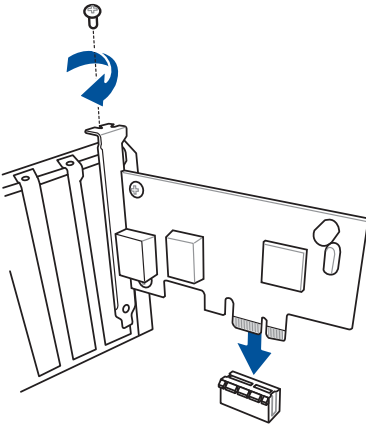

To install PCIe x4 cards

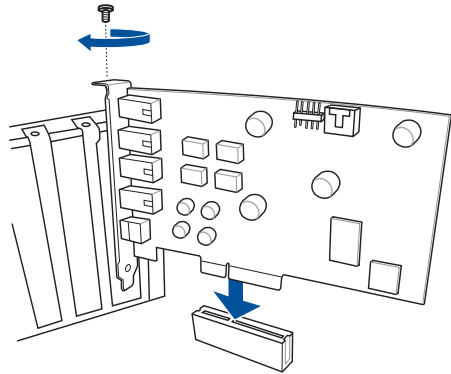

## 2.1.9 M.2 installation

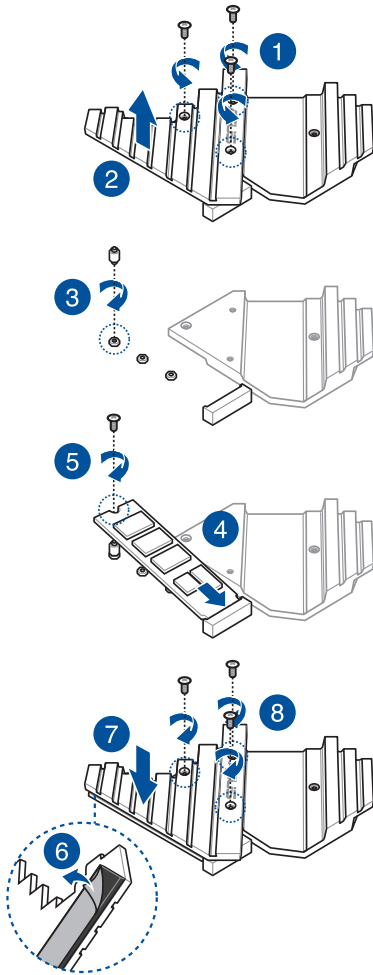

OR

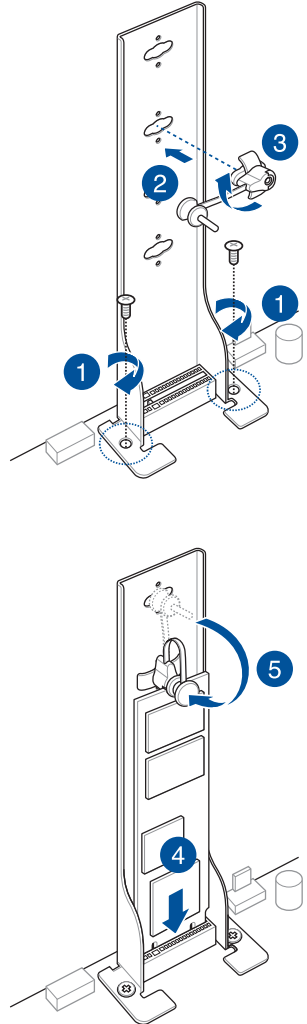

Supported M.2 type varies per motherboard.

## 2.2 BIOS update utility

### USB BIOS Flashback

USB BIOS Flashback allows you to easily update the BIOS without entering the existing BIOS or operating system. Simply insert a USB storage device to the USB port (the USB port hole marked in green on the I/O shield) then press the USB BIOS Flashback button for three seconds to automatically update the BIOS.

#### To use USB BIOS Flashback:

1. Insert a USB storage device to the USB Flashback port.
2. Visit <https://www.asus.com/support/> and download the latest BIOS version for this motherboard.
3. Rename the file as **PX399A.CAP**, then copy it to your USB storage device.
4. Shut down your computer.
5. Press the BIOS Flashback button for three seconds until the Flashback LED blinks three times, indicating that the BIOS Flashback function is enabled.

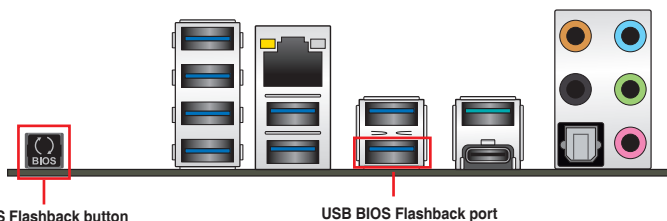

6. Wait until the light goes out, indicating that the BIOS updating process is completed.



For more BIOS update utilities in BIOS setup, refer to the section **3.11 Updating BIOS** in Chapter 3.



- Do not unplug portable disk, power system, or press the CLR\_CMOS button while BIOS update is ongoing, otherwise update will be interrupted. In case of interruption, please follow the steps again.
- If the light flashes for five seconds and turns into a solid light, this means that the BIOS Flashback is not operating properly. This may be caused by improper installation of the USB storage device and filename/file format error. If this scenario happens, please restart the system to turn off the light.
- Updating BIOS may have risks. If the BIOS program is damaged during the process and results to the system's failure to boot up, please contact your local ASUS Service Center.

## 2.3 Motherboard rear and audio connections

### 2.3.1 Rear I/O connection

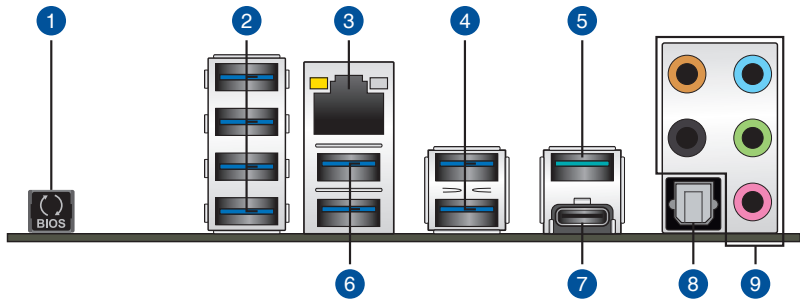

#### Rear panel connectors

1. USB BIOS Flashback button	6. USB 3.1 Gen 1 ports 3, 4
2. USB 3.1 Gen 1 ports 5, 6, 7, and 8.	7. USB 3.1 Gen 2 Type-C™ port EC1
3. LAN (RJ-45) port*	8. Optical S/PDIF Out port
4. USB 3.1 Gen 1 ports 1, 2 (bottom port supports USB BIOS Flashback)	9. Audio jacks**
5. USB 3.1 Gen 2 Type-A port EA2	

\* and \*\*: Refer to the tables on the next page for LAN port LEDs and audio port definitions.



- USB 3.1 Gen 1 / Gen 2 devices can only be used as data storage only.
- We strongly recommend that you connect your devices to ports with matching data transfer rate. Please connect your USB 3.1 Gen 1 devices to USB 3.1 Gen 1 ports and your USB 3.1 Gen 2 devices to USB 3.1 Gen 2 ports for faster and better performance for your devices.

## \* LAN ports LED indications

Activity Link LED		Speed LED	
Status	Description	Status	Description
Off	No link	Off	10 Mbps connection
Orange	Linked	Orange	100 Mbps connection
Orange (Blinking)	Data activity	Green	1 Gbps connection
Orange (Blinking then steady)	Ready to wake up from S5 mode	–	–

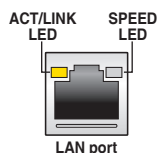

You can disable the LAN controllers in BIOS. Due to hardware design, the LAN port's LEDs may continue to blink even when disabled.

## \*\* Audio 2, 4, 6 or 8-channel configuration

Port	Headset 2-channel	4-channel	6-channel	8-channel
Light Blue	Line In	Line In	Line In	Side Speaker Out
Lime	Line Out	Front Speaker Out	Front Speaker Out	Front Speaker Out
Pink	Mic In	Mic In	Mic In	Mic In
Orange	–	–	Center/Sub woofer	Center/Sub woofer
Black	–	Rear Speaker Out	Rear Speaker Out	Rear Speaker Out

## 2.3.2 Audio I/O connections

### Audio I/O ports

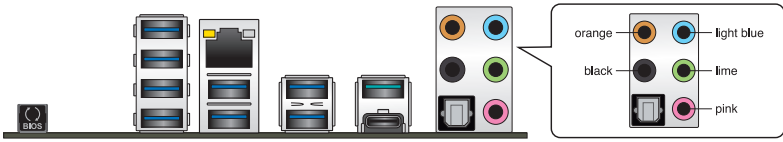

### Connect to Headphone and Mic



### Connect to Stereo Speakers

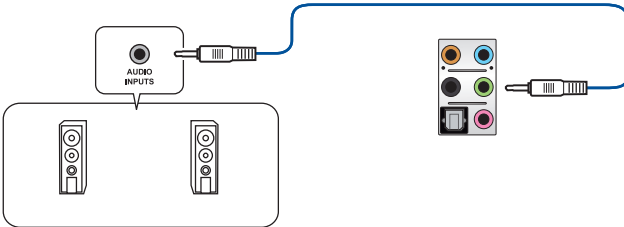

### Connect to 2 Speakers

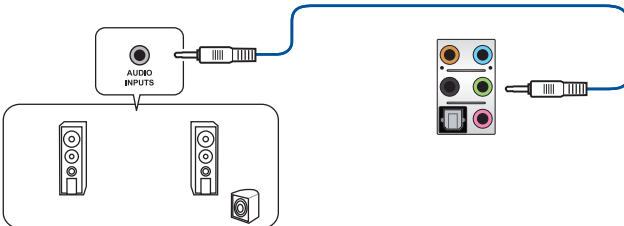

## Connect to 4 Speakers

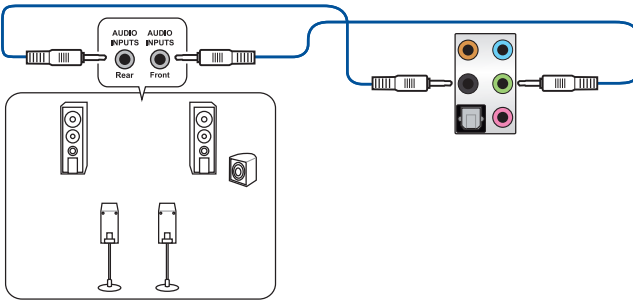

## Connect to 6 Speakers

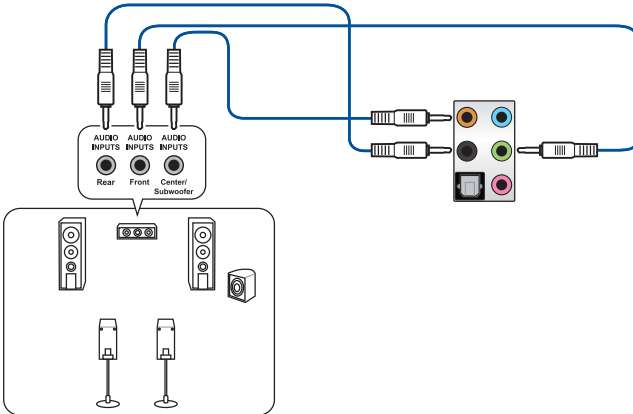

## Connect to 8 Speakers

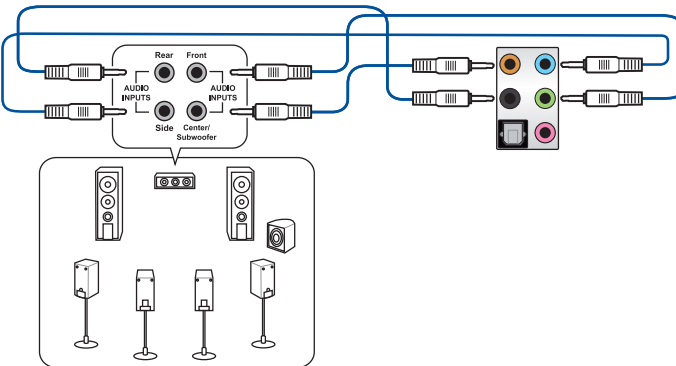



## 2.4 Starting up for the first time

1. After making all the connections, replace the system case cover.
2. Ensure that all switches are off.
3. Connect the power cord to the power connector at the back of the system chassis.
4. Connect the power cord to a power outlet that is equipped with a surge protector.
5. Turn on the devices in the following order:
  - a. Monitor
  - b. External SCSI devices (starting with the last device on the chain)
  - c. System power
6. After applying power, the system power LED on the system front panel case lights up. For systems with ATX power supplies, the system LED lights up when you press the ATX power button. If your monitor complies with the “green” standards or if it has a “power standby” feature, the monitor LED may light up or change from orange to green after the system LED turns on.

The system then runs the power-on self tests (POST). While the tests are running, the BIOS beeps (refer to the BIOS beep codes table) or additional messages appear on the screen. If you do not see anything within 30 seconds from the time you turned on the power, the system may have failed a power-on test. Check the jumper settings and connections or call your retailer for assistance.

BIOS Beep	Description
One short beep	VGA detected Quick boot set to disabled No keyboard detected
One continuous beep followed by three short beeps	No VGA detected
One continuous beep followed by four short beeps	Hardware component failure

7. At power on, hold down the <Delete> key to enter the BIOS Setup. Follow the instructions in Chapter 3.

## 2.5 Turning off the computer

While the system is ON, press the power button for less than four seconds to put the system on sleep mode or soft-off mode, depending on the BIOS setting. Press the power switch for more than four seconds to let the system enter the soft-off mode regardless of the BIOS setting.



# BIOS Setup

# 3

## 3.1 Knowing BIOS



---

The new ASUS UEFI BIOS is a Unified Extensible Interface that complies with UEFI architecture, offering a user-friendly interface that goes beyond the traditional keyboard-only BIOS controls to enable a more flexible and convenient mouse input. You can easily navigate the new UEFI BIOS with the same smoothness as your operating system. The term "BIOS" in this user manual refers to "UEFI BIOS" unless otherwise specified.

---

BIOS (Basic Input and Output System) stores system hardware settings such as storage device configuration, overclocking settings, advanced power management, and boot device configuration that are needed for system startup in the motherboard CMOS. In normal circumstances, the default BIOS settings apply to most conditions to ensure optimal performance. **DO NOT change the default BIOS settings** except in the following circumstances:

- An error message appears on the screen during the system bootup and requests you to run the BIOS Setup.
- You have installed a new system component that requires further BIOS settings or update.



---

Inappropriate BIOS settings may result to instability or boot failure. **We strongly recommend that you change the BIOS settings only with the help of a trained service personnel.**

---



- When downloading or updating the BIOS file, rename it as **PX399A.CAP** for this motherboard.
  - BIOS settings and options may vary due to different BIOS release versions. Please refer to the latest BIOS version for settings and options.
-

## 3.2 BIOS setup program

Use the BIOS Setup to update the BIOS or configure its parameters. The BIOS screen include navigation keys and brief onscreen help to guide you in using the BIOS Setup program.

### Entering BIOS at startup

To enter BIOS Setup at startup, press <Delete> or <F2> during the Power-On Self Test (POST). If you do not press <Delete> or <F2>, POST continues with its routines.

### Entering BIOS Setup after POST

To enter BIOS Setup after POST:

- Press <Ctrl>+<Alt>+<Delete> simultaneously.
- Press the reset button on the system chassis.
- Press the power button to turn the system off then back on. Do this option only if you failed to enter BIOS Setup using the first two options.

After doing either of the three options, press <Delete> key to enter BIOS.



- 
- The BIOS setup screens shown in this section are for reference purposes only, and may not exactly match what you see on your screen.
  - Ensure that a USB mouse is connected to your motherboard if you want to use the mouse to control the BIOS setup program.
  - If the system becomes unstable after changing any BIOS setting, load the default settings to ensure system compatibility and stability. Select the **Load Optimized Defaults** item under the **Exit** menu or press hotkey <F5>. See section **3.10 Exit Menu** for details.
  - If the system fails to boot after changing any BIOS setting, try to clear the CMOS and reset the motherboard to the default value. See section **1.1.6 Jumpers, buttons and holes** for information on how to erase the RTC RAM via the Clear CMOS button.
  - The BIOS setup program does not support the Bluetooth devices.
- 



---

Please visit ASUS website for the detailed BIOS content manual.

---

### BIOS menu screen

The BIOS Setup program can be used under two modes: **EZ Mode** and **Advanced Mode**. You can change modes from **Setup Mode** in **Boot menu** or by pressing the <F7> hotkey.

### 3.2.1 EZ Mode

By default, the EZ Mode screen appears when you enter the BIOS setup program. The EZ Mode provides you an overview of the basic system information, and allows you to select the display language, system performance, mode and boot device priority. To access the Advanced Mode, select **Advanced Mode** or press the <F7> hotkey for the advanced BIOS settings.



The default screen for entering the BIOS setup program can be changed. Refer to the **Setup Mode** item in section **Boot menu** for details.

The screenshot shows the ASUS UEFI BIOS Utility in EZ Mode. The interface is divided into several sections:

- Information:** Displays system properties like BIOS version (PRIME X399-A BIOS Ver. 0304), processor (AMD Ryzen Threadripper 1920 12-Core Processor), speed (3600 MHz), and memory (8192 MB).
- CPU Temperature:** Shows CPU Core Voltage (1.373 V) and Motherboard Temperature (33°C).
- DRAM Status:** Lists DIMM slots and their contents (e.g., DIMM\_A1: Samsung 8192MB 2133MHz).
- SATA Information:** Lists SATA ports and their configurations.
- FAN Profile:** Allows selection of fan profiles (CPU FAN, CHA\_FAN1-3, CPU\_OPT, EXT\_FAN2) and manual tuning via the QFan Control graph.
- EZ System Tuning:** Offers power-saving system environment settings (Quiet, Performance, Energy Saving).
- Boot Priority:** Allows selection of boot devices (e.g., 3SYSTEM USB Flash Disk 1.00).
- Navigation:** Includes buttons for Default(F5), Save & Exit(F10), Advanced Mode(F7), and Search on FAQ.

Callouts provide the following descriptions:

- Displays the system properties of the selected mode. Click < or > to switch EZ System Tuning modes** (points to EZ System Tuning)
- Displays the CPU/motherboard temperature, CPU voltage output, CPU/chassis/power fan speed, and SATA information** (points to Information, CPU Temperature, and SATA Information)
- Selects the display language of the BIOS setup program** (points to English)
- Configures system overclocking** (points to EZ System Tuning)
- Displays the CPU Fan's speed. Click the button to manually tune the fans** (points to QFan Control)
- Saves the changes and resets the system** (points to Save & Exit(F10))
- Click to go to Advanced mode** (points to Advanced Mode(F7))
- Search on the FAQ** (points to Search on FAQ)
- Click to display boot devices** (points to Boot Priority)
- Selects the boot device priority** (points to Boot Priority)
- Loads optimized default settings** (points to Default(F5))



The boot device options vary depending on the devices you installed to the system.

### 3.2.2 Advanced Mode

The Advanced Mode provides advanced options for experienced end-users to configure the BIOS settings. The figure below shows an example of the Advanced Mode. Refer to the following sections for the detailed configurations.



To switch from EZ Mode to Advanced Mode, click **Advanced Mode(F7)** or press the <F7> hotkey.

**Configuration fields**

**Menu bar** Language MyFavorite(F3) Qfan Control(F6) EZ Tuning Wizard(F11) Hot Keys **Scroll bar**

ASUS UEFI BIOS Utility - Advanced Mode  
01/13/2011 Thursday 05:55 English MyFavorite(F3) Qfan Control(F6) EZ Tuning Wizard(F11) Hot Keys

My Favorites Main **AI Tweaker** Advanced Monitor Boot Tool Exit Hardware Monitor

Target CPU Speed : 3200MHz  
Target DRAM Frequency : 2133MHz

Overclocking Presets

AI Overclock Tuner [Auto]

Custom CPU Core Ratio [Auto]

> CPU Core Ratio [Auto]

Performance Bias [Auto]

Memory Frequency [Auto]

Core Performance Boost [Auto]

SMT Mode [Auto]

Spread Spectrum [Enabled]

EPU Power Saving Mode [Disabled]

Simultaneous multithreading. Default is Enabled.

**Hardware Monitor**

**CPU**

Frequency	Temperature
4000 MHz	46°C
BCLK	Core Voltage
100.0 MHz	1.308 V
Ratio	
40.0 x	

**Memory**

Frequency	Vol_CHAB
2133 MHz	1.199 V
Capacity	Vol_CHCD
8192 MB	1.199 V

**Voltage**

+12V	+5V
11.837 V	5.068 V
+3.3V	
3.313 V	

Version 2.17.1246. Copyright (C) 2017 American Megatrends, Inc.

Last Modified EzMode(F7) Search on FAQ

**Menu items** **General help** **Last modified settings** **Go back to EZ Mode** **Search on the FAQ**

**Pop-up Menu** **Displays the CPU temperature, CPU, and memory voltage output**

## Menu bar

The menu bar on top of the screen has the following main items:

<b>My Favorites</b>	For saving the frequently-used system settings and configuration.
<b>Main</b>	For changing the basic system configuration
<b>Ai Tweaker</b>	For changing the overclocking settings
<b>Advanced</b>	For changing the advanced system settings
<b>Monitor</b>	For displaying the system temperature, power status, and changing the fan settings.
<b>Boot</b>	For changing the system boot configuration
<b>Tool</b>	For configuring options for special functions
<b>Exit</b>	For selecting the exit options and loading default settings

## Menu items

The highlighted item on the menu bar displays the specific items for that menu. For example, selecting **Main** shows the Main menu items.

The other items (My Favorites, Ai Tweaker, Advanced, Monitor, Boot, Tool, and Exit) on the menu bar have their respective menu items.

## Submenu items

A greater than sign (>) before each item on any menu screen means that the item has a submenu. To display the submenu, select the item and press <Enter>.

## Language

This button above the menu bar contains the languages that you can select for your BIOS. Click this button to select the language that you want to display in your BIOS screen.

## My Favorites (F3)

This button above the menu bar shows all BIOS items in a Tree Map setup. Select frequently-used BIOS settings and save it to MyFavorites menu.



---

Refer to section **3.3 My Favorites** for more information.

---

## Q-Fan Control (F6)

This button above the menu bar displays the current settings of your fans. Use this button to manually tweak the fans to your desired settings.



---

Refer to section **3.2.3 QFan Control** for more information.

---

## EZ Tuning Wizard (F11)

This button above the menu bar allows you to view and tweak the overclocking settings of your system. It also allows you to change the motherboard's SATA mode from AHCI to RAID mode.



---

Refer to section **3.2.4 EZ Tuning Wizard** for more information.

---

## Search on FAQ

Move your mouse over this button to show a QR code, scan this QR code on your mobile device to connect to the BIOS FAQ web page of the ASUS support website. You can also scan the following QR code:



## Hot keys

This button above the menu bar contains the navigation keys for the BIOS setup program. Use the navigation keys to select items in the menu and change the settings.

## Scroll bar

A scroll bar appears on the right side of a menu screen when there are items that do not fit on the screen. Press the Up/Down arrow keys or <Page Up> / <Page Down> keys to display the other items on the screen.

## General help

At the bottom of the menu screen is a brief description of the selected item. Use <F12> key to capture the BIOS screen and save it to the removable storage device.

## Configuration fields

These fields show the values for the menu items. If an item is user-configurable, you can change the value of the field opposite the item. You cannot select an item that is not user-configurable.

A configurable field is highlighted when selected. To change the value of a field, select it and press <Enter> to display a list of options.

## Last Modified button

This button shows the items that you last modified and saved in BIOS Setup.



### 3.2.3 QFan Control

The QFan Control allows you to set a fan profile or manually configure the operating speed of your CPU and chassis fans.

The screenshot shows the QFan Control utility interface. At the top, it says "Q-Fan Control" and provides instructions: "Select your target fan and then move the slider to select any of these profiles: Standard, Silent, Turbo and Full Speed). You can also move the slider to Manual and manually configure the fan's operating speed." Below this, there are two tabs: "PWM" (selected) and "DC". A graph shows fan speed (%) on the y-axis (0 to 100) and temperature (°C) on the x-axis (0 to 100). A blue line represents the fan speed profile, which is flat at approximately 25% until 30°C, then rises to about 75% at 70°C, and finally reaches 100% at 100°C. Below the graph are five radio buttons for profiles: "Standard" (selected), "Silent", "Turbo", "Full Speed", and "Manual". At the bottom, there are three buttons: "Undo", "Apply", and "Exit (ESC)".

Annotations with red lines pointing to specific elements:

- Click to select a fan to be configured (points to the fan list)
- Click to activate PWM Mode (points to the PWM tab)
- Click to activate DC Mode (points to the DC tab)
- Select a profile to apply to your fans (points to the Standard radio button)
- Click to apply the fan setting (points to the Apply button)
- Click to undo the changes (points to the Undo button)
- Click to go back to main menu (points to the Exit (ESC) button)
- Select to manually configure your fans (points to the Manual radio button)

## Configuring fans manually

Select **Manual** from the list of profiles to manually configure your fans' operating speed.

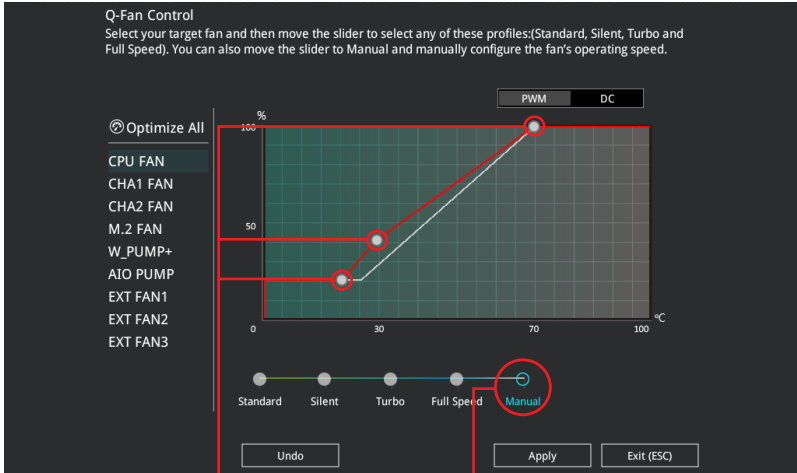

Speed points

Select to manually  
configure your fans

To configure your fans:

1. Select the fan that you want to configure and to view its current status.
2. Click and drag the speed points to adjust the fans' operating speed.
3. Click **Apply** to save the changes then click **Exit (ESC)**.

## 3.2.4 EZ Tuning Wizard

EZ Tuning Wizard allows you to easily overclock your CPU and DRAM, computer usage, and CPU fan to their best settings.

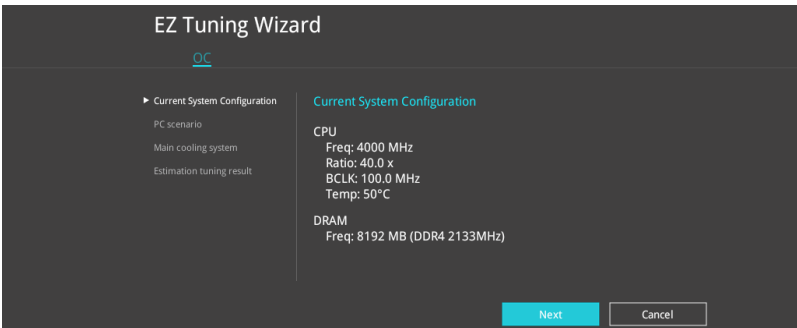

## OC Tuning

To start OC Tuning:

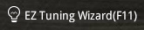
1. Press <F11> on your keyboard or click  from the BIOS screen to open EZ Tuning Wizard screen.
2. Select a PC scenario **Daily Computing** or **Gaming/Media Editing**, then click **Next**.

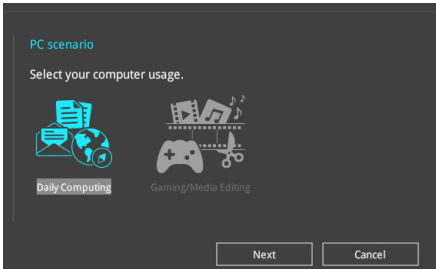

3. Select a Main Cooling System **BOX cooler**, **Tower cooler**, **Water cooler**, or **I'm not sure**, then click **Next**.

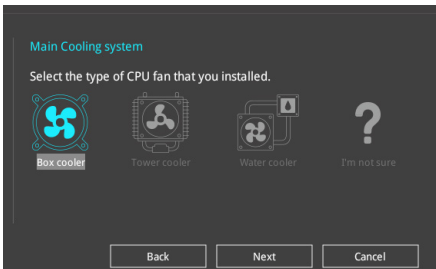

4. After selecting the Main Cooling System, click **Next** then click **Yes** to start the OC Tuning.

### 3.3 My Favorites

My Favorites is your personal space where you can easily save and access your favorite BIOS items. My Favorites comes with several performance, power saving, and fast boot related items by default. You can personalize this screen by adding or removing items.

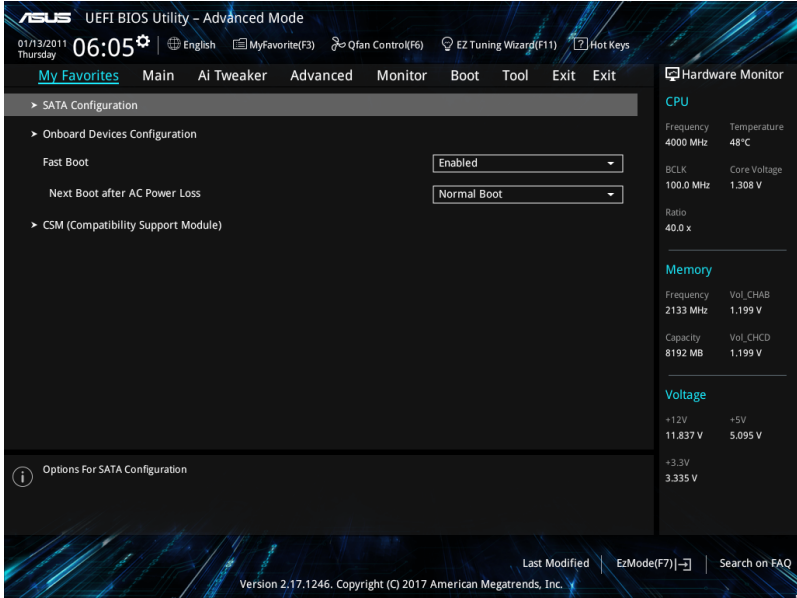

## Adding items to My Favorites

To add BIOS items:

1. Press <F3> on your keyboard or click  (F3)MyFavorite from the BIOS screen to open Setup Tree Map screen.
2. On the Setup Tree Map screen, select the BIOS items that you want to save in My Favorites screen.

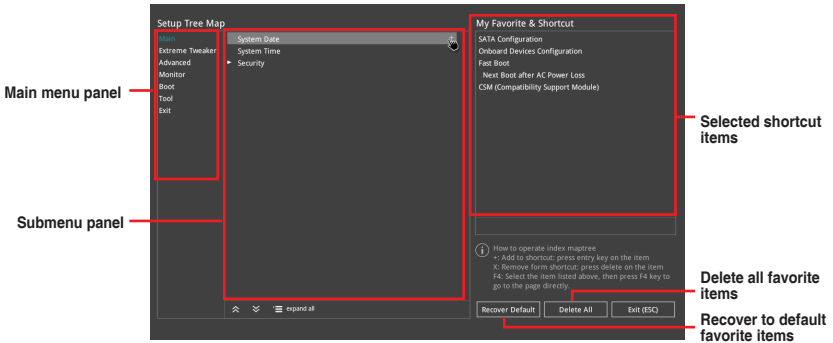

3. Select an item from main menu panel, then click the submenu that you want to save as favorite from the submenu panel and click  or press <Enter> on your keyboard.



You cannot add user-managed items such as language and boot order to My Favorites.

4. Click **Exit (ESC)** or press <Esc> key to close Setup Tree Map screen.
5. Go to My Favorites menu to view the saved BIOS items.

## 3.4 Main menu

The Main menu screen appears when you enter the Advanced Mode of the BIOS Setup program. The Main menu provides you an overview of the basic system information, and allows you to set the system date, time, language, and security settings.

### Security

The Security menu items allow you to change the system security settings.



- If you have forgotten your BIOS password, erase the CMOS Real Time Clock (RTC) RAM to clear the BIOS password. See section 1.1.6 **Jumpers, buttons and holes** for information on how to erase the RTC RAM via the Clear CMOS button.
- The Administrator or User Password items on top of the screen show the default **[Not Installed]**. After you set a password, these items show **[Installed]**.

## 3.5 Ai Tweaker menu

The Extreme Tweaker menu items allow you to configure overclocking-related items.



Be cautious when changing the settings of the Extreme Tweaker menu items. Incorrect field values can cause the system to malfunction



The configuration options for this section vary depending on the CPU and DIMM model you installed on the motherboard.

### Ai Overclock Tuner

Allows you to select the CPU overclocking options to achieve the desired CPU internal frequency. Configuration options:

- |            |  |
|------------|--|
| [Auto]     | Loads the optimal settings for the system.   |
| [Manual]   | Allows you to individually set overclocking parameters.  |
| [D.O.C.P.] | Allows you to select a DRAM O.C. profile, and the related parameters will be adjusted automatically. |



The following items appear only when you set the Ai Overclock Tuner to **[Manual]**.

#### BCLK Frequency

This item allows you to set the BCLK (base clock) frequency to enhance the system performance. Use the <+> or <-> to adjust the value.



We recommend you to set the value based on the CPU specification, as high BCLK frequencies may damage the CPU permanently.

#### Custom CPU Core Ratio

This item allows you to set a custom CPU core ratio. The CPU core ratio is calculated with the formula:  $2 * FID / DID$ . Configuration options: [Auto] [Manual]



The following items appear only when you set the **Custom CPU Core Ratio** to **[Manual]**.

## FID

This item allows you to set the core frequency multiplier. Use the <+> or <-> to adjust the value.

## DID

This item allows you to set the core frequency divisor. Use the <+> or <-> to adjust the value.

## Memory Frequency

This item allows you to set the memory operating frequency. The configurable options vary with the BCLK (base clock) frequency setting. Select the auto mode to apply the optimized setting. Configuration options: [Auto] [DDR4-1333MHz] - [DDR4-4000MHz]

## 3.6 Advanced menu

The Advanced menu items allow you to change the settings for the CPU and other system devices.



Be cautious when changing the settings of the Advanced menu items. Incorrect field values can cause the system to malfunction.

### 3.6.1 Trusted Computing

#### Security Device Support [Enable]

Allows you to enable or disable BIOS support for security devices. Configuration options: [Disable] [Enable]

### 3.6.2 AMD fTPM Configuration

The items in this menu allow you to configure the TPM settings.

### 3.6.3 SATA Configuration

While entering Setup, the BIOS automatically detects the presence of SATA devices. The SATA Port items show **Not Present** if no SATA device is installed to the corresponding SATA port.

#### SATA Port Enable

This item allows you to enable or disable the SATA Device. Configuration options: [Disabled] [Enabled]

#### SATA Mode

This item allows you to set the SATA configuration.

[AHCI] Set to [AHCI] when you want the SATA hard disk drives to use the AHCI (Advanced Host Controller Interface). The AHCI allows the onboard storage driver to enable advanced Serial ATA features that increases storage performance on random workloads by allowing the drive to internally optimize the order of commands.

[RAID] Set to [RAID] when you want to create a RAID configuration from the SATA hard disk drives.

## SMART Self Test

S.M.A.R.T. (Self-Monitoring, Analysis and Reporting Technology) is a monitoring system that shows a warning message during POST (Power-on Self Test) when an error occurs in the hard disks. Configuration options: [On] [Off]

## SATA6G\_1(Gray) - SATA6G\_6(Gray)

### SATA6G\_1 - SATA6G\_6

This item allows you to rename the selected SATA port. Configuration options: [Disabled] [Enabled]

### Hot Plug

These items appears only when the **SATA Mode** is set to [AHCI] and allows you to enable or disable SATA Hot Plug Support. Configuration options: [Disabled] [Enabled]

## 3.6.4 Onboard Devices Configuration

The items in this menu allow you to switch between PCIe Lanes and configure onboard devices.

### HD Audio Controller

This item allows you to enable or disable the Azalia High Definition Audio Controller. Configuration options: [Disabled] [Enabled]

### CPU PCIE Link Mode

This item allows you to set the M.2/PCIE link speed. Configuration options: [Auto] [GEN 1] [GEN 2] [GEN 3]

### SB PCIE Link Mode

This item allows you to set the Southbridge link speed. Configuration options: [Auto] [GEN 1] [GEN 2] [GEN 3]

### PCIEX16\_1 Bandwidth

[X16 Mode] The PCIe x16\_1 slot runs at x16 mode.

[PCIe RAID Mode] The four PCIe x16 slots all run at x4 mode, which allows you to create a RAID array of up to 4 PCIe devices.



---

Use PCIe RAID Mode when installing the Hyper M.2 x16 card or other M.2 adapter cards. Installing other devices when using PCIe RAID Mode may cause your PC to fail to boot up.

---

### PCIEX16\_2 Bandwidth

[X8 Mode] The PCIe x16\_2 slot runs at x8 mode.

[PCIe RAID Mode] The PCIe x16\_2 slot runs at x4 mode, which allows you to create a RAID array of 2 PCIe devices.

### PCIEX16\_3 Bandwidth

[X16 Mode] The PCIe x16\_3 slot runs at x16 mode.

[PCIe RAID Mode] The four PCIe x16 slots all run at x4 mode, which allows you to create a RAID array of up to 4 PCIe devices.



### PCIEX16\_4 Bandwidth

[X8 Mode] The PCIe x16\_4 slot runs at x8 mode.

[PCIe RAID Mode] The PCIe x16\_4 slot runs at x4 mode, which allows you to create a RAID array of 2 PCIe devices.

### Asmedia USB 3.1 Controller

[Disabled] Disables the controller.

[Enabled] Enables the rear USB 3.1 controller.

### USB Type C Power Switch for U31G2\_1 / U31G2\_EC1

[Auto] The system will automatically detect your USB Type C devices and provide suitable power if needed.

[Enabled] The USB Type C port will always provide power to your devices.

### RGB LED lighting

#### When system is in working state

This item allows you to turn the RGB LED lighting on or off when the system is in the working state. Configuration options: [On] [Off]

#### When system is in sleep, hibernate or soft off states

This item allows you to turn the RGB LED lighting on or off when the system is in the sleep, hibernate or soft off states. Configuration options: [On] [Off]

### Intel LAN Controller

This item allows you to enable or disable the Intel LAN controllers. Configuration options: [Disabled] [Enabled]

## 3.6.5 APM Configuration

The items in this menu allow you to set system wake and sleep settings.

### ErP Ready

This item allows you to switch off some power at S4+S5 or S5 to get the system ready for ErP requirement. When set to **[Enabled]**, all other PME options are switched off. Configuration options: [Disabled] [Enable(S4+S5)] [Enable(S5)]

### Restore On AC Power Loss

This item allows your system to go to ON state, OFF state, or both states after an AC power loss. When setting your system to **[Last State]**, it goes to the previous state before the AC power loss. Configuration options: [Power On] [Power Off] [Last State]

### Power On By PCI-E

This item allows you to enable or disable the Wake-on-LAN function of the onboard LAN controller or other installed PCI-E LAN cards. Configuration options: [Disabled] [Enabled]

### Power On By RTC

This item allows you to enable or disable the RTC (Real-Time Clock) to generate a wake event and configure the RTC alarm date. When enabled, you can set the days, hours, minutes, or seconds to schedule an RTC alarm date. Configuration options: [Disabled] [Enabled]

## 3.6.6 CPU Configuration

The items in this menu show the CPU-related information that the BIOS automatically detects.



---

The items in this menu may vary based on the CPU installed.

---

### NX Mode

This item allows you enable or disable no-execute page protection function. Configuration options: [Disabled] [Enabled]

### SVM Mode

This item allows you enable or disable CPU Virtualization. Configuration options: [Disabled] [Enabled]

## 3.6.7 Network Stack Configuration

The items in this menu allow you to enable or disable the UEFI network stack

## 3.6.8 HDD/SSD SMART Information

This menu displays the SMART information of the connected devices.



---

NVM Express devices do not support SMART information.

---

## 3.6.9 USB Configuration

The items in this menu allow you to change the USB-related features.



---

The **Mass Storage Devices** item shows the auto-detected values. If no USB device is detected, the item shows **None**.

---

### Legacy USB Support

- [Enabled] Your system supports the USB devices in legacy operating systems.
- [Disabled] Your USB devices can be used for BIOS setup only and cannot be recognized in the boot devices list.
- [Auto] Your system automatically detects the presence of USB devices at startup. If any USB devices are detected, the legacy USB support is enabled.

### XHCI Hand-off

- [Enabled] Enables the support for operating systems without an XHCI hand-off feature.
- [Disabled] Disables the XHCI Hand-off support.

### USB Mass Storage Driver Support

This item allows you to enable or disable USB Mass Storage Driver Support. Configuration options: [Disabled] [Enabled]

## USB Single Port Control

These items allow you to enable or disable the individual USB ports.



---

Refer to section **1.1.2 Motherboard layout** for the location of the USB ports.

---

### 3.6.10 AMD PBS

The items in this menu display the CPU-related information that the BIOS automatically detects.



---

This item appears only when you install an AMD Ryzen™ processor.

---

### Enumerate all IOMMU in IVRS

- [Enabled] Allows the IOMMU on the primary CPU die to map all device-visible virtual addresses.
- [Disabled] Enables the IOMMU on both CPU dies to map device-visible virtual addresses.

### NVMe RAID mode

This item allows you enable or disable the NVMe RAID mode. Configuration options: [Disabled] [Enabled]

## 3.7 Monitor menu

The Monitor menu displays the system temperature/power status, and allows you to change the fan settings.

### Q-fan Configuration

#### Qfan Tuning

Click this item to automatically detect the lowest speed and configure the minimum duty cycle for each fan.

#### W\_PUMP+ Control

- [Disabled] Disable the Water Pump control feature.
- [Auto] Detects the type of water pump installed and automatically switches the control modes.
- [DC mode] Enable the Water Pump control in DC mode for 3-pin chassis fan.
- [PWM mode] Enable the Water Pump control in PWM mode for 4-pin chassis fan.

## 3.8 Boot menu

The Boot menu items allow you to change the system boot options.

### Fast Boot

[Disabled] Allows your system to go back to its normal boot speed.

[Enabled] Allows your system to accelerate the boot speed.



---

The following items appear only when you set the Fast Boot to **[Enabled]**.

---

### Next Boot after AC Power Loss

[Normal Boot] Returns to normal boot on the next boot after an AC power loss.

[Fast Boot] Accelerates the boot speed on the next boot after an AC power loss.

## Boot Configuration

### Boot Logo Display

[Auto] Sets the boot logo to display during POST.

[Full Screen] Sets the boot logo display in full screen during POST.

[Disabled] Disables the boot logo display during POST.

### Setup Mode

[Advanced Mode] This item allows you to go to Advanced Mode of the BIOS after POST.

[EZ Mode] This item allows you to go to EZ Mode of the BIOS after POST.

## CSM (Compatibility Support Module)

This item allows you to configure the CSM (Compatibility Support Module) items to fully support the various VGA, bootable devices and add-on devices for better compatibility.

### Launch CSM

[Auto] The system automatically detects the bootable devices and the add-on devices.

[Enabled] For better compatibility, enable the CSM to fully support the non-UEFI driver add-on devices or the Windows® UEFI mode.

[Disabled] Disable the CSM to fully support the non-UEFI driver add-on devices or the Windows® UEFI mode.



---

The following items appear only when you set the Launch CSM to **[Enabled]**.

---

### Boot Devices Control

This item allows you to select the type of devices that you want to boot. Configuration options: [UEFI and Legacy OPROM] [Legacy OPROM only] [UEFI only]

### Boot from Network Devices

This item allows you to select the type of network devices that you want to launch. Configuration options: [Ignore] [Legacy only] [UEFI driver first]

**Boot from Storage Devices**

This item allows you to select the type of storage devices that you want to launch. Configuration options: [Ignore] [Legacy only] [UEFI driver first]

**Boot from PCI-E Expansion Devices**

This item allows you to select the type of PCI-E/PCI expansion devices that you want to launch. Configuration options: [Legacy only] [UEFI driver first]

**Secure Boot**

This item allows you to configure the Windows® Secure Boot settings and manage its keys to protect the system from unauthorized access and malwares during POST.

**Boot Option Priorities**

These items specify the boot device priority sequence from the available devices. The number of device items that appears on the screen depends on the number of devices installed in the system.



- To access Windows® OS in Safe Mode, press <F8> after POST (Windows® 8 not supported).
- To select the boot device during system startup, press <F8> when the ASUS Logo appears.

**Boot Override**

These items displays the available devices. The number of device items that appears on the screen depends on the number of devices installed in the system. Click an item to start booting from the selected device.

**3.9 Tool menu**

The Tool menu items allow you to configure options for special functions. Select an item then press <Enter> to display the submenu.

**Setup Animator**

This item allows you to enable or disable the Setup animator.

Configuration options: [Disabled] [Enabled]

**3.9.1 ASUS EZ Flash 3 Utility**

This item allows you to run ASUS EZ Flash 3. When you press <Enter>, a confirmation message appears. Use the left/right arrow key to select between [Yes] or [No], then press <Enter> to confirm your choice.



For more details, refer to section **3.11.2 ASUS EZ Flash 3**.

### 3.9.2 Secure Erase

SSD speeds may lower over time as with any storage medium due to data processing. Secure Erase completely and safely cleans your SSD, restoring it to factory performance levels.



Secure Erase is only available in AHCI mode. Ensure to set the SATA mode to AHCI. Click **Advanced > SATA Configuration > SATA Mode > AHCI**.

To launch Secure Erase, click **Tool > Secure Erase** on the Advanced mode menu.



Secure Erase is only supported on selected SATA SSDs, and cannot erase NVMe storage devices.



- The time to erase the contents of your SSD may take a while depending on its size. Do not turn off the system during the process.
- Secure Erase is only supported on AMD SATA port. For more information about AMD SATA ports, refer to section 1.1.2 **Motherboard layout** of this manual.

Displays the available SSDs

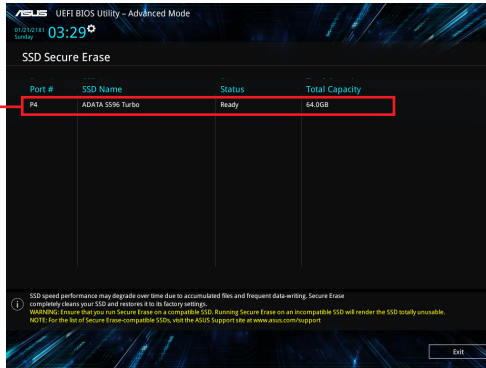

#### Status definition:

- **Frozen.** The frozen state is the result of a BIOS protective measure. The BIOS guards drives that do not have password protection by freezing them prior to booting. If the drive is frozen, a power off or hard reset of your PC must be performed to proceed with the Secure Erase.
- **Locked.** SSDs might be locked if the Secure Erase process is either incomplete or was stopped. This may be due to a third party software that uses a different password defined by ASUS. You have to unlock the SSD in the software before proceeding with Secure Erase.

### 3.9.3 ASUS Overclocking Profile

This item allows you to store or load multiple BIOS settings.

#### Load from Profile

This item allows you to load the previous BIOS settings saved in the BIOS Flash. Key in the profile number that saved your BIOS settings, press <Enter>, and then select **Yes**.



- DO NOT shut down or reset the system while updating the BIOS to prevent the system boot failure!
- We recommend that you update the BIOS file only coming from the same memory/ CPU configuration and BIOS version.

#### Profile Name

This item allows you to key in a profile name.

#### Save to Profile

This item allows you to save the current BIOS settings to the BIOS Flash, and create a profile. Key in a profile number from one to eight, press <Enter>, and then select **Yes**.

#### Load/Save Profile from/to USB Drive

This item allows you to load or save profile from your USB drive, load and save profile to your USB drive.

### 3.9.4 ASUS SPD Information

This item allows you to view the DRAM SPD information.

### 3.9.5 Graphics Card Information

This item displays the information about the graphics card installed in your system.

#### GPU Post

This item displays the information and recommended configuration for the PCIe slots that the graphics card is installed in your system.



This feature is only supported on selected ASUS graphics cards.

#### Bus Interface

This item allows you to select the bus interface. Configuration options: [PCIEX16\_1] [PCIEX16\_2] [PCIEX16\_3] [PCIEX16\_4]

## 3.10 Exit menu

The Exit menu items allow you to load the optimal default values for the BIOS items, and save or discard your changes to the BIOS items. You can access the EZ Mode from the Exit menu.

### Load Optimized Defaults

This option allows you to load the default values for each of the parameters on the Setup menus. When you select this option or if you press <F5>, a confirmation window appears. Select **OK** to load the default values.

### Save Changes & Reset

Once you are finished making your selections, choose this option from the Exit menu to ensure the values you selected are saved. When you select this option or if you press <F10>, a confirmation window appears. Select **OK** to save changes and exit.

### Discard Changes and Exit

This option allows you to exit the Setup program without saving your changes. When you select this option or if you press <Esc>, a confirmation window appears. Select **Yes** to discard changes and exit.

### Launch EFI Shell from USB drives

This item allows you to attempt to launch the EFI Shell application (shellx64.efi) from one of the available filesystem devices.



## 3.11 Updating BIOS

The ASUS website publishes the latest BIOS versions to provide enhancements on system stability, compatibility, and performance. However, BIOS updating is potentially risky. If there is no problem using the current version of BIOS, DO NOT manually update the BIOS. Inappropriate BIOS updating may result to system's failure to boot. Carefully follow the instructions in this chapter to update your BIOS when necessary.



---

Visit <http://www.asus.com> to download the latest BIOS file for this motherboard.

---

The following utilities allow you to manage and update the motherboard BIOS setup program.

1. EZ Update: Updates the BIOS in Windows® environment.
2. ASUS EZ Flash 3: Updates the BIOS using a USB flash drive.
3. ASUS CrashFree BIOS 3: Restores the BIOS using the motherboard support DVD or a USB flash drive when the BIOS file fails or gets corrupted.

### 3.11.1 EZ Update

The EZ Update is a utility that allows you to update the motherboard BIOS in Windows® environment.



- EZ Update requires an Internet connection either through a network or an ISP (Internet Service Provider).
  - This utility is available in the support DVD that comes with the motherboard package.
-

### 3.11.2 ASUS EZ Flash 3

ASUS EZ Flash 3 allows you to download and update to the latest BIOS through the Internet without having to use a bootable floppy disk or an OS-based utility.



Updating through the Internet varies per region and Internet conditions. Check your local Internet connection before updating through the Internet.

#### To update the BIOS by USB:

1. Enter the Advanced Mode of the BIOS setup program. Go to the Tool menu to select **ASUS EZ Flash Utility** and press <Enter>.
2. Insert the USB flash disk that contains the latest BIOS file to the USB port.
3. Select **via Storage Device(s)**.

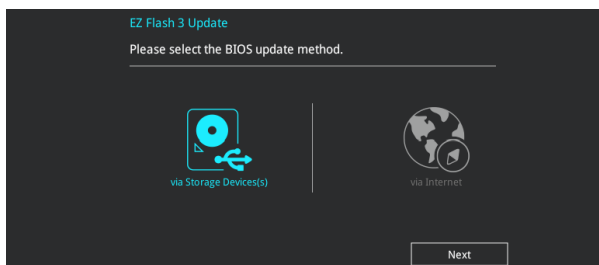

4. Press <Tab> to switch to the Drive field.
5. Press the Up/Down arrow keys to find the USB flash disk that contains the latest BIOS, and then press <Enter>.
6. Press <Tab> to switch to the Folder Info field.
7. Press the Up/Down arrow keys to find the BIOS file, and then press <Enter> to perform the BIOS update process. Reboot the system when the update process is done.





- This function can support devices such as a USB flash disk with FAT 32/16 format and single partition only.
- DO NOT shut down or reset the system while updating the BIOS to prevent system boot failure!



Ensure to load the BIOS default settings to ensure system compatibility and stability. Select the Load Optimized Defaults item under the Exit menu. See section **3.10 Exit Menu** for details.

### To update the BIOS by Internet:

1. Enter the Advanced Mode of the BIOS setup program. Go to the Tool menu to select **ASUS EZ Flash 3 Utility** and press <Enter>.
2. Select **via Internet**.

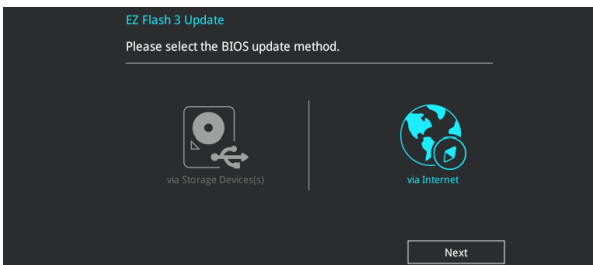

3. Press the Left/Right arrow keys to select an Internet connection method, and then press <Enter>.

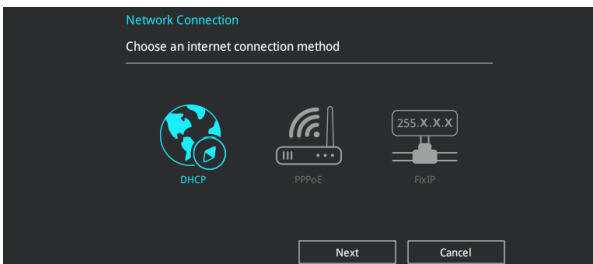

4. Follow the onscreen instructions to complete the update.
5. Reboot the system when the update process is done.



Ensure to load the BIOS default settings to ensure system compatibility and stability. Select the Load Optimized Defaults item under the Exit menu. See section **3.10 Exit Menu** for details.

### 3.11.3 ASUS CrashFree BIOS 3

The ASUS CrashFree BIOS 3 utility is an auto recovery tool that allows you to restore the BIOS file when it fails or gets corrupted during the updating process. You can restore a corrupted BIOS file using the motherboard support DVD or a USB flash drive that contains the BIOS file.



---

The BIOS file in the motherboard support DVD may be older than the BIOS file published on the ASUS official website. If you want to use the newer BIOS file, download the file at <https://www.asus.com/support/> and save it to a USB flash drive.

---

#### Recovering the BIOS

##### To recover the BIOS:

1. Turn on the system.
2. Insert the motherboard support DVD to the optical drive, or the USB flash drive containing the BIOS file to the USB port.
3. The utility automatically checks the devices for the BIOS file. When found, the utility reads the BIOS file and enters ASUS EZ Flash 3 automatically.
4. The system requires you to enter BIOS Setup to recover the BIOS setting. To ensure system compatibility and stability, we recommend that you press <F5> to load default BIOS values.



---

DO NOT shut down or reset the system while updating the BIOS! Doing so can cause system boot failure!

---

# RAID Support

# 4

## 4.1 AMD RAID Array configurations

The motherboard comes with the RaidXpert2 Configuration Utility that supports Volume, RAIDABLE, RAID 0, RAID 1, and RAID 10 (depends on system licensing) configurations.



---

If you want to install a Windows® operating system to a hard disk drive included in a RAID set, you have to create a RAID driver disk and load the RAID driver during OS installation. Refer to section **4.2 Creating a RAID driver disk** for details.

---

### 4.1.1 RAID definitions

**Volume** provides the ability to link-together storage from one or several disks, regardless of the size of the space on those disks. This configuration is useful in scavenging space on disks unused by other disks in the array. This configuration does not provide performance benefits or data redundancy, disk failure will result in data loss.

**RAIDABLE** arrays (also known as RAID Ready) are a special type of Volume (JBOD) that allows the user to add more storage space or create a redundant array after a system is installed. RAIDABLE arrays are created using Option ROM, UEFI, or roadm.



---

The ability to create RAIDABLE arrays may vary per system.

---

**RAID 0 (Data striping)** optimizes two identical hard disk drives to read and write data in parallel, interleaved stacks. Two hard disks perform the same work as a single drive but at a sustained data transfer rate, double that of a single disk alone, thus improving data access and storage. Use of two new identical hard disk drives is required for this setup.

**RAID 1 (Data mirroring)** copies and maintains an identical image of data from one drive to a second drive. If one drive fails, the disk array management software directs all applications to the surviving drive as it contains a complete copy of the data in the other drive. This RAID configuration provides data protection and increases fault tolerance to the entire system. Use two new drives or use an existing drive and a new drive for this setup. The new drive must be of the same size or larger than the existing drive.

**RAID 10** is data striping and data mirroring combined without parity (redundancy data) having to be calculated and written. With the RAID 10 configuration you get all the benefits of both RAID 0 and RAID 1 configurations. Use four new hard disk drives or use an existing drive and three new drives for this setup.

## 4.1.2 Installing storage devices

The motherboard supports Serial ATA hard disk drives and NVMe SSD storage devices. For optimal performance, install identical drives of the same model and capacity when creating a disk array.



Refer to Chapter 2 of this user manual for details on installing storage devices to your motherboard.

## 4.1.3 RaidXpert2 Configuration Utility in UEFI BIOS

To enter the RaidXpert2 Configuration Utility in UEFI BIOS:

1. Enter the BIOS Setup during POST.



Refer to Chapter 3 of this user manual for details on entering and navigating through the BIOS Setup.

2. Go to **Advanced > SATA Configuration**, then set **SATA Mode** to **[RAID]**.



Due to chipset limitation, when SATA ports are set to RAID mode, all SATA ports run at RAID mode together.

3. Configure additional settings for your storage device and RAID configuration:
  - If you are using Hyper M.2 x16 cards, go to **Advanced > Onboard Devices Configuration**, then set all the corresponding PCIe slots to **[PCIe RAID Mode]**.



The Hyper M.2 x16 card is purchased separately.

- If you are setting up an NVMe RAID set, go to **Advanced > AMD PBS**, then set **NVMe RAID mode** to **[Enabled]**.
4. Go to **Boot > CSM (Compatibility Support Module)**, then set **Launch CSM** to **[Disabled]**.
5. Save your changes and exit the BIOS Setup, then enter the BIOS Setup again.
6. Go to **Advanced > RaidXpert2 Configuration Utility** to display the RaidXpert2 Configuration Utility menu.

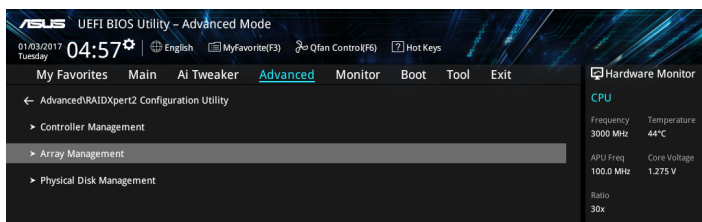

## Creating a RAID set

To create a RAID set:

1. From the RAIDxpert2 Configuration Utility menu, go to **Array Management > Create Array** to enter the Create Array menu. The following screen appears:

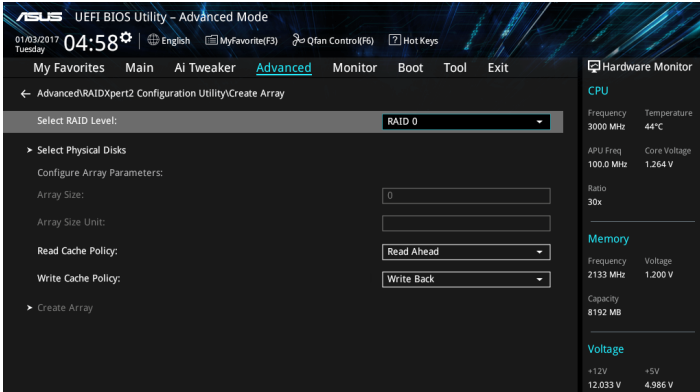

2. When the RAID Level item is selected, press <Enter> to select the RAID level to create, and then press <Enter>.
3. Under Select Physical Disks, press <Enter>. The following screen appears.

You can select SATA, SSD or both. Turn **ON** the disks you want to include in the RAID set and select **Apply Changes**, then press <Enter>.

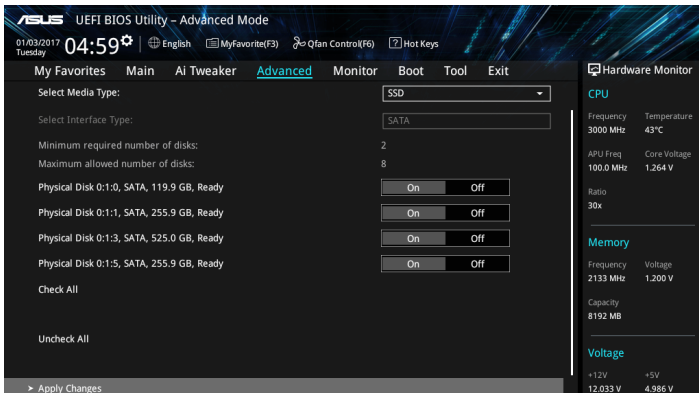

- When return to the RAIDXpert2 Configuration Utility menu, select the Array Size and other detailed policies, press <Enter>. Save changes when finish.



You can specify the array size to be created. Choosing the value 0 will set the maximum supported array size when a valid configuration is selected.

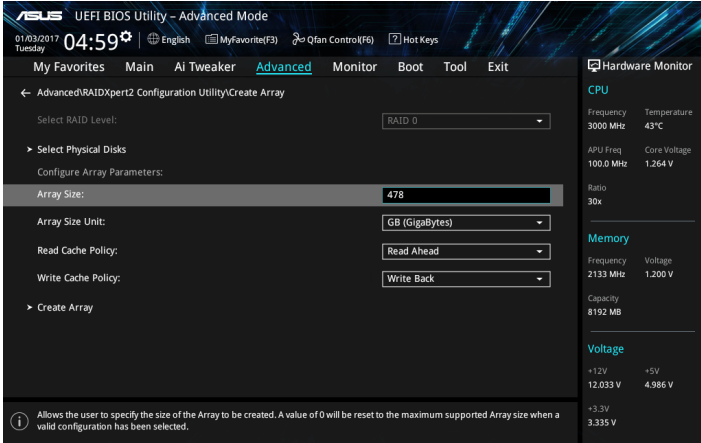

## Deleting a RAID set



Be cautious when deleting a RAID set. You will lose all data on the hard disk drives when you delete a RAID set.

To delete a RAID set:

- Select **RAIDXpert2 Configuration Utility > Delete Array** and press <Enter>. Select the Array you want to delete and select **Delete Array**, press <Enter>.

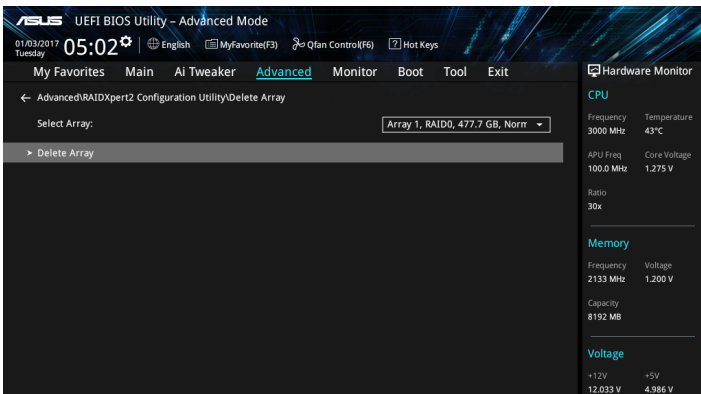



2. Select **On** to confirm your choice and then select **Yes** to delete the RAID Array and return to the **RAIDXpert2 Configuration Utility** menu, or select **No** to cancel.

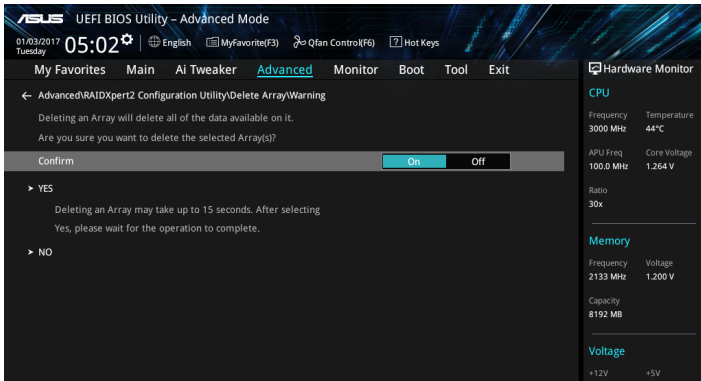

## 4.2 Creating a RAID driver disk

### 4.2.1 Creating a RAID driver disk in Windows®

To install the RAID driver for Windows® OS:

1. During the OS installation, click **Load Driver** to allow you to select the installation media containing the RAID driver.
2. Insert the supported USB flash drive with RAID driver into the USB port, and then click **Browse**.
3. Click the name of the device you've inserted, go to **Drivers > RAID**, and then select the RAID Bottom drivers first and click **OK**, then select the RAID driver for the corresponding OS version, click **OK**.
4. Follow the succeeding screen instructions to complete the installation.



To set up a Windows® UEFI operating system under RAID mode, ensure to load the UEFI driver for your optical drive.



# Appendix

## Notices

### Federal Communications Commission Statement

This device complies with Part 15 of the FCC Rules. Operation is subject to the following two conditions:

- This device may not cause harmful interference.
- This device must accept any interference received including interference that may cause undesired operation.

This equipment has been tested and found to comply with the limits for a Class B digital device, pursuant to Part 15 of the FCC Rules. These limits are designed to provide reasonable protection against harmful interference in a residential installation. This equipment generates, uses and can radiate radio frequency energy and, if not installed and used in accordance with manufacturer's instructions, may cause harmful interference to radio communications. However, there is no guarantee that interference will not occur in a particular installation. If this equipment does cause harmful interference to radio or television reception, which can be determined by turning the equipment off and on, the user is encouraged to try to correct the interference by one or more of the following measures:

- Reorient or relocate the receiving antenna.
- Increase the separation between the equipment and receiver.
- Connect the equipment to an outlet on a circuit different from that to which the receiver is connected.
- Consult the dealer or an experienced radio/TV technician for help.



The use of shielded cables for connection of the monitor to the graphics card is required to assure compliance with FCC regulations. Changes or modifications to this unit not expressly approved by the party responsible for compliance could void the user's authority to operate this equipment.

---

## Compliance Statement of Innovation, Science and Economic Development Canada (ISED)

This Class B digital apparatus complies with Canadian ICES-003, RSS-210, and CAN ICES-3(B)/NMB-3(B).

This device complies with Industry Canada license exempt RSS standard(s). Operation is subject to the following two conditions: (1) this device may not cause interference, and (2) this device must accept any interference, including interference that may cause undesired operation of the device.

## Déclaration de conformité de Innovation, Sciences et Développement économique Canada (ISED)

Cet appareil numérique de classe B est conforme aux normes canadiennes ICES-003, RSS-210 et CAN ICES-3(B)/NMB-3(B).

Cet appareil est conforme aux normes CNR exemptes de licence d'Industrie Canada. Le fonctionnement est soumis aux deux conditions suivantes : (1) cet appareil ne doit pas provoquer d'interférences et (2) cet appareil doit accepter toute interférence, y compris celles susceptibles de provoquer un fonctionnement non souhaité de l'appareil.

## VCCI: Japan Compliance Statement

### Class B ITE

この装置は、クラスB情報技術装置です。この装置は、家庭環境で使用することを目的としていますが、この装置がラジオやテレビジョン受信機に近接して使用されると、受信障害を引き起こすことがあります。

取扱説明書に従って正しい取り扱いをして下さい。

VCCI-B

## KC: Korea Warning Statement

**B급 기기 (가정용 방송통신기자재)**

이 기기는 가정용(B급) 전자파적합기기로서 주로 가정에서 사용하는 것을 목적으로 하며, 모든 지역에서 사용할 수 있습니다.

## REACH

Complying with the REACH (Registration, Evaluation, Authorisation, and Restriction of Chemicals) regulatory framework, we published the chemical substances in our products at ASUS REACH website at <http://csr.asus.com/english/REACH.htm>.



DO NOT throw the motherboard in municipal waste. This product has been designed to enable proper reuse of parts and recycling. This symbol of the crossed out wheeled bin indicates that the product (electrical and electronic equipment) should not be placed in municipal waste. Check local regulations for disposal of electronic products.



DO NOT throw the mercury-containing button cell battery in municipal waste. This symbol of the crossed out wheeled bin indicates that the battery should not be placed in municipal waste.

## ASUS Recycling/Takeback Services

ASUS recycling and takeback programs come from our commitment to the highest standards for protecting our environment. We believe in providing solutions for you to be able to responsibly recycle our products, batteries, other components as well as the packaging materials. Please go to <http://csr.asus.com/english/Takeback.htm> for detailed recycling information in different regions.

## Regional notice for California



### WARNING

Cancer and Reproductive Harm -  
[www.P65Warnings.ca.gov](http://www.P65Warnings.ca.gov)

## Google™ License Terms

Copyright© 2018 Google Inc. All Rights Reserved.

Licensed under the Apache License, Version 2.0 (the “License”); you may not use this file except in compliance with the License. You may obtain a copy of the License at:

<http://www.apache.org/licenses/LICENSE-2.0>

Unless required by applicable law or agreed to in writing, software distributed under the License is distributed on an “AS IS” BASIS, WITHOUT WARRANTIES OR CONDITIONS OF ANY KIND, either express or implied.

See the License for the specific language governing permissions and limitations under the License.

**English** ASUSTeK Computer Inc. hereby declares that this device is in compliance with the essential requirements and other relevant provisions of related Directives. Full text of EU declaration of conformity is available at: [www.asus.com/support](http://www.asus.com/support)

**Français** AsusTek Computer Inc. déclare par la présente que cet appareil est conforme aux critères essentiels et autres clauses pertinentes des directives concernées. La déclaration de conformité de l'UE peut être téléchargée à partir du site Internet suivant: [www.asus.com/support](http://www.asus.com/support).

**Deutsch** ASUSTeK Computer Inc. erklärt hiermit, dass dieses Gerät mit den wesentlichen Anforderungen und anderen relevanten Bestimmungen der zugehörigen Richtlinien übereinstimmt. Der gesamte Text der EU-Konformitätserklärung ist verfügbar unter: [www.asus.com/support](http://www.asus.com/support)

**Italiano** ASUSTeK Computer Inc. con la presente dichiara che questo dispositivo è conforme ai requisiti essenziali e alle altre disposizioni pertinenti con le direttive correlate. Il testo completo della dichiarazione di conformità UE è disponibile all'indirizzo: [www.asus.com/support](http://www.asus.com/support)

**Русский** Компания ASUS заявляет, что это устройство соответствует основным требованиям и другим соответствующим условиям соответствующих директив. Подробную информацию, пожалуйста, смотрите на [www.asus.com/support](http://www.asus.com/support)

**Български** С настоящото ASUSTeK Computer Inc. декларира, че това устройство е в съответствие със съществените изисквания и другите приложими постановления на свързаните директиви. Пълният текст на декларацията за съответствие на ЕС е достъпен на адрес: [www.asus.com/support](http://www.asus.com/support)

**Hrvatski** ASUSTeK Computer Inc. ovim izjavljuje da je ovaj uređaj sukladan s bitnim zahtjevima i ostalim odgovarajućim odredbama vezanih direktiva. Cijeli tekst EU izjave o sukladnosti dostupan je na: [www.asus.com/support](http://www.asus.com/support)

**Čeština** Společnost ASUSTeK Computer Inc. tímto prohlašuje, že toto zařízení splňuje základní požadavky a další příslušná ustanovení souvisejících směrnic. Plné znění prohlášení o shodě EU je k dispozici na adrese: [www.asus.com/support](http://www.asus.com/support)

**Dansk** ASUSTeK Computer Inc. erklærer hermed, at denne enhed er i overensstemmelse med hovedkravene og andre relevante bestemmelser i de relaterede direktiver. Hele EU-overensstemmelseserklæringen kan findes på: [www.asus.com/support](http://www.asus.com/support)

**Nederlands** ASUSTeK Computer Inc. verklaart hierbij dat dit apparaat voldoet aan de essentiële vereisten en andere relevante bepalingen van de verwante richtlijnen. De volledige tekst van de EU-verklaring van conformiteit is beschikbaar op: [www.asus.com/support](http://www.asus.com/support)

**Eesti** Käesolevaga kinnitab ASUSTeK Computer Inc, et see seade vastab asjakohaste direktiivide olulistele nõuetele ja teisteles ajaspeetuvatele sätetele. El vastavusdeklaratsiooni täielik tekst on saadaval järgmisel aadressil: [www.asus.com/support](http://www.asus.com/support)

**Suomi** ASUSTeK Computer Inc. ilmoittaa täten, että tämä laite on asiaankuuluvien direktiivien olennaisien vaatimusten ja muiden tätä koskevien säädösten mukainen. EU-yhdenmukaisuusilmoituksen koko teksti on luettavissa osoitteessa: [www.asus.com/support](http://www.asus.com/support)

**Ελληνικά** Με το παρόν, η ASUSTeK Computer Inc. δηλώνει ότι αυτή η συσκευή συμμορφώνεται με τις θεμελιώδεις απαιτήσεις και άλλες σχετικές διατάξεις των Οδηγιών της ΕΕ. Το πλήρες κείμενο της δήλωσης συμμόρφωσης είναι διαθέσιμο στη διεύθυνση: [www.asus.com/support](http://www.asus.com/support)

**Magyar** Az ASUSTeK Computer Inc. ezennel kijelenti, hogy ez az eszköz megfelel a kapcsolódó irányelvek lényeges követelményeinek és egyéb vonatkozó rendelkezéseinek. Az EU megfélelősegi nyilatkozat teljes szövege innen letölthető: [www.asus.com/support](http://www.asus.com/support)

**Latviski** ASUSTeK Computer Inc. ar šo paziņo, ka šī ierīce atbilst saistošo Direktīvu būtiskajām prasībām un citiem citiem saistošajiem nosacījumiem. Pilns ES atbilstības paziņojuma teksts pieejams šeit: [www.asus.com/support](http://www.asus.com/support)

**Lietuvių** „ASUSTeK Computer Inc.“ šiuo tvirtina, kad šis įrenginys atitinka pagrindinius reikalavimus ir kitas svarbias susijusių direktyvų nuostatas. Visą ES atitikties deklaracijos tekstą galima rasti: [www.asus.com/support](http://www.asus.com/support)

**Norsk** ASUSTeK Computer Inc. erklærer herved at denne enheten er i samsvar med hovedsaklige krav og andre relevante forskrifter i relaterte direktiver. Fullstendig tekst for EU-samsvarserklæringen finnes på: [www.asus.com/support](http://www.asus.com/support)

**Polski** Firma ASUSTeK Computer Inc. niniejszym oświadcza, że urządzenie to jest zgodne z zasadniczymi wymogami i innymi właściwymi postanowieniami powiązanych dyrektyw. Pełny tekst deklaracji zgodności UE jest dostępny pod adresem: [www.asus.com/support](http://www.asus.com/support)

**Português** A ASUSTeK Computer Inc. declara que este dispositivo está em conformidade com os requisitos essenciais e outras disposições relevantes das Diretivas relacionadas. Texto integral da declaração da UE disponível em: [www.asus.com/support](http://www.asus.com/support)

**Română** ASUSTeK Computer Inc. declară că acest dispozitiv se conformează cerințelor esențiale și altor prevederi relevante ale directivelor conexe. Textul complet al declarației de conformitate a Uniunii Europene se găsește la: [www.asus.com/support](http://www.asus.com/support)

**Srpski** ASUSTeK Computer Inc. ovim izjavljuje da je ovaj uređaj u saglasnosti sa osnovnim zahtevima i drugim relevantnijim odredbama povezanih Direktiva. Pun tekst EU deklaracije o usaglasenosti je dostupan da adres: [www.asus.com/support](http://www.asus.com/support)

**Slovensky** Spoločnosť ASUSTeK Computer Inc. týmto vyhlasuje, že toto zariadenie vyhovuje základným požiadavkám a ostatým príslušným ustanoveniam príslušných smerníc. Celý text vyhlásenia o zhode pre štáty EÚ je dostupný na adrese: [www.asus.com/support](http://www.asus.com/support)

**Slovenščina** ASUSTeK Computer Inc. izjavlja, da je ta naprava skladna z bistvenimi zahtevami in drugimi ustreznimi določbami povezanih direktiv. Celotno besedilo EU-izjave o skladnosti je na voljo na spletnem mestu: [www.asus.com/support](http://www.asus.com/support)

**Español** Por la presente, ASUSTeK Computer Inc. declara que este dispositivo cumple los requisitos básicos y otras disposiciones pertinentes de las directivas relacionadas. El texto completo de la declaración de la UE de conformidad está disponible en: [www.asus.com/support](http://www.asus.com/support)

**Svenska** ASUSTeK Computer Inc. förklarar härmed att denna enhet överensstämmer med de grundläggande kraven och andra relevanta föreskrifter i relaterade direktiv. Fulltext av EU-försäkran om överensstämmelse finns på: [www.asus.com/support](http://www.asus.com/support)

**Українська** ASUSTeK Computer Inc. заявляє, що цей пристрій відповідає основним вимогам та іншим відповідним положенням відповідних Директив. Повний текст декларації відповідності стандартам ЄС доступний на: [www.asus.com/support](http://www.asus.com/support)

**Türkçe** ASUSTeK Computer Inc., bu aygıtın temel gereksinimlerle ve ilişkili Yönergelerin diğer ilgili kullarıyla uyumlu olduğunu beyan eder. AB uygunluk bildirimini tam metni şu adreste bulunabilir: [www.asus.com/support](http://www.asus.com/support)

**Bosanski** ASUSTeK Computer Inc. ovim izjavljuje da je ovaj uređaj uskladen sa bitnim zahtjevima i ostalim odgovarajućim odredbama vezanih direktiva. Cijeli tekst EU izjave o uskladenosti dostupan je na: [www.asus.com/support](http://www.asus.com/support)

## ASUS contact information

### ASUSTeK COMPUTER INC.

Address 4F, No. 150, Li-Te Road, Peitou, Taipei 112, Taiwan  
Telephone +886-2-2894-3447  
Fax +886-2-2890-7798  
Web site [www.asus.com](http://www.asus.com)

#### **Technical Support**

Telephone +86-21-38429911  
Fax +86-21-5866-8722, ext. 9101#  
Online support <http://qr.asus.com/techserv>

### ASUS COMPUTER INTERNATIONAL (America)

Address 800 Corporate Way, Fremont, CA 94539, USA  
Telephone +1-510-739-3777  
Fax +1-510-608-4555  
Web site <http://www.asus.com/us/>

#### **Technical Support**

Support fax +1-812-284-0883  
Telephone +1-812-282-2787  
Online support <http://qr.asus.com/techserv>

### ASUS COMPUTER GmbH (Germany and Austria)

Address Harkort Str. 21-23, 40880 Ratingen, Germany  
Fax +49-2102-959931  
Web site <http://www.asus.com/de>  
Online contact <http://eu-rma.asus.com/sales>

#### **Technical Support**

Telephone +49-2102-5789555  
Support Fax +49-2102-959911  
Online support <http://qr.asus.com/techserv>

# DECLARATION OF CONFORMITY

Per FCC Part 2 Section 2. 1077(a)



**Responsible Party Name:** **Asus Computer International**

**Address:** **800 Corporate Way, Fremont, CA 94539.**

**Phone/Fax No:** **(510)739-3777/(510)608-4555**

hereby declares that the product

**Product Name : Motherboard**

**Model Number : PRIME X399-A**

Conforms to the following specifications:

FCC Part 15, Subpart B, Unintentional Radiators

### **Supplementary Information:**

This device complies with part 15 of the FCC Rules. Operation is subject to the following two conditions: (1) This device may not cause harmful interference, and (2) this device must accept any interference received, including interference that may cause undesired operation.

Representative Person's Name : Steve Chang / President

A handwritten signature in blue ink that reads "Steve Chang".

Signature :

Date : Aug. 05, 2017

Ver. 170324