

**STRIX X99  
GAMING**

**ASUS®**

**Motherboard**

E11712  
Revised Edition V2  
May 2016

**Copyright© 2016 ASUSTeK COMPUTER INC. All Rights Reserved.**

No part of this manual, including the products and software described in it, may be reproduced, transmitted, transcribed, stored in a retrieval system, or translated into any language in any form or by any means, except documentation kept by the purchaser for backup purposes, without the express written permission of ASUSTeK COMPUTER INC. ("ASUS").

Product warranty or service will not be extended if: (1) the product is repaired, modified or altered, unless such repair, modification of alteration is authorized in writing by ASUS; or (2) the serial number of the product is defaced or missing.

ASUS PROVIDES THIS MANUAL "AS IS" WITHOUT WARRANTY OF ANY KIND, EITHER EXPRESS OR IMPLIED, INCLUDING BUT NOT LIMITED TO THE IMPLIED WARRANTIES OR CONDITIONS OF MERCHANTABILITY OR FITNESS FOR A PARTICULAR PURPOSE. IN NO EVENT SHALL ASUS, ITS DIRECTORS, OFFICERS, EMPLOYEES OR AGENTS BE LIABLE FOR ANY INDIRECT, SPECIAL, INCIDENTAL, OR CONSEQUENTIAL DAMAGES (INCLUDING DAMAGES FOR LOSS OF PROFITS, LOSS OF BUSINESS, LOSS OF USE OR DATA, INTERRUPTION OF BUSINESS AND THE LIKE), EVEN IF ASUS HAS BEEN ADVISED OF THE POSSIBILITY OF SUCH DAMAGES ARISING FROM ANY DEFECT OR ERROR IN THIS MANUAL OR PRODUCT.

SPECIFICATIONS AND INFORMATION CONTAINED IN THIS MANUAL ARE FURNISHED FOR INFORMATIONAL USE ONLY, AND ARE SUBJECT TO CHANGE AT ANY TIME WITHOUT NOTICE, AND SHOULD NOT BE CONSTRUED AS A COMMITMENT BY ASUS. ASUS ASSUMES NO RESPONSIBILITY OR LIABILITY FOR ANY ERRORS OR INACCURACIES THAT MAY APPEAR IN THIS MANUAL, INCLUDING THE PRODUCTS AND SOFTWARE DESCRIBED IN IT.

Products and corporate names appearing in this manual may or may not be registered trademarks or copyrights of their respective companies, and are used only for identification or explanation and to the owners' benefit, without intent to infringe.

**Offer to Provide Source Code of Certain Software**

This product contains copyrighted software that is licensed under the General Public License ("GPL"), under the Lesser General Public License Version ("LGPL") and/or other Free Open Source Software Licenses. Such software in this product is distributed without any warranty to the extent permitted by the applicable law. Copies of these licenses are included in this product.

Where the applicable license entitles you to the source code of such software and/or other additional data, you may obtain it for a period of three years after our last shipment of the product, either

(1) for free by downloading it from <https://www.asus.com/support/>

or

(2) for the cost of reproduction and shipment, which is dependent on the preferred carrier and the location where you want to have it shipped to, by sending a request to:

ASUSTeK Computer Inc.  
Legal Compliance Dept.  
15 Li Te Rd.,  
Beitou, Taipei 112  
Taiwan

In your request please provide the name, model number and version, as stated in the About Box of the product for which you wish to obtain the corresponding source code and your contact details so that we can coordinate the terms and cost of shipment with you.

The source code will be distributed WITHOUT ANY WARRANTY and licensed under the same license as the corresponding binary/object code.

This offer is valid to anyone in receipt of this information.

ASUSTeK is eager to duly provide complete source code as required under various Free Open Source Software licenses. If however you encounter any problems in obtaining the full corresponding source code we would be much obliged if you give us a notification to the email address [gpl@asus.com](mailto:gpl@asus.com), stating the product and describing the problem (please DO NOT send large attachments such as source code archives, etc. to this email address).

# Contents

Safety information.....	vi
About this guide.....	vii
STRIX X99 GAMING specifications summary.....	ix
Package contents.....	xiii
Installation tools and components.....	xiv

## Chapter 1: Product Introduction

<b>1.1</b>	<b>Motherboard overview.....</b>	<b>1-1</b>
1.1.1	Before you proceed.....	1-1
1.1.2	Motherboard layout.....	1-2
1.1.3	Central Processing Unit (CPU).....	1-4
1.1.4	System memory.....	1-5
1.1.5	Expansion slots.....	1-8
1.1.6	Onboard buttons and switches.....	1-10
1.1.7	Jumpers.....	1-13
1.1.8	Onboard LEDs.....	1-15
1.1.9	Internal connectors.....	1-22

## Chapter 2: Basic Installation

<b>2.1</b>	<b>Building your PC system.....</b>	<b>2-1</b>
2.1.1	Motherboard installation.....	2-1
2.1.2	CPU installation.....	2-3
2.1.3	CPU heatsink and fan assembly installation.....	2-4
2.1.4	DIMM installation.....	2-6
2.1.5	ATX Power connection.....	2-7
2.1.6	SATA device connection.....	2-8
2.1.7	Front I/O Connector.....	2-9
2.1.8	Expansion Card installation.....	2-10
2.1.9	Wi-Fi antenna installation.....	2-12
<b>2.2</b>	<b>BIOS update utility.....</b>	<b>2-13</b>
<b>2.3</b>	<b>Motherboard rear and audio connections.....</b>	<b>2-14</b>
2.3.1	Rear I/O connection.....	2-14
2.3.2	Audio I/O connections.....	2-16
<b>2.4</b>	<b>Starting up for the first time.....</b>	<b>2-18</b>
<b>2.5</b>	<b>Turning off the computer.....</b>	<b>2-19</b>

## Chapter 3: BIOS Setup

<b>3.1</b>	<b>Knowing BIOS</b> .....	<b>3-1</b>
<b>3.2</b>	<b>BIOS setup program</b> .....	<b>3-2</b>
	3.2.1 EZ Mode.....	3-3
	3.2.2 Advanced Mode .....	3-4
	3.2.3 QFan Control.....	3-7
	3.2.4 EZ Tuning Wizard .....	3-9
<b>3.3</b>	<b>My Favorites</b> .....	<b>3-12</b>
<b>3.4</b>	<b>Main menu</b> .....	<b>3-14</b>
<b>3.5</b>	<b>Ai Tweaker menu</b> .....	<b>3-15</b>
<b>3.6</b>	<b>Advanced menu</b> .....	<b>3-19</b>
	3.6.1 CPU Configuration .....	3-20
	3.6.2 PCH Configuration .....	3-21
	3.6.3 PCH Storage Configuration.....	3-22
	3.6.4 System Agent Configuration .....	3-24
	3.6.5 USB Configuration .....	3-24
	3.6.6 Platform Misc Configuration.....	3-25
	3.6.7 Onboard Devices Configuration.....	3-25
	3.6.8 APM Configuration.....	3-28
	3.6.9 Network Stack Configuration.....	3-28
	3.6.10 HDD/SSD SMART Configuration .....	3-29
	3.6.11 NVMe Configuration.....	3-29
<b>3.7</b>	<b>Monitor menu</b> .....	<b>3-30</b>
<b>3.8</b>	<b>Boot menu</b> .....	<b>3-32</b>
<b>3.9</b>	<b>Tool menu</b> .....	<b>3-35</b>
	3.9.1 ASUS EZ Flash 3 Utility .....	3-35
	3.9.2 Secure Erase .....	3-36
	3.9.3 ASUS Overclocking Profile .....	3-37
	3.9.4 ASUS SPD Information .....	3-38
<b>3.10</b>	<b>Exit menu</b> .....	<b>3-39</b>
<b>3.11</b>	<b>Updating BIOS</b> .....	<b>3-40</b>
	3.11.1 EZ Update.....	3-40
	3.11.2 ASUS EZ Flash 3.....	3-40
	3.11.3 ASUS CrashFree BIOS 3.....	3-43



<b>Chapter 4:</b>	<b>RAID Support</b>	
<b>4.1</b>	<b>RAID configurations</b>	<b>4-1</b>
4.1.1	RAID definitions	4-1
4.1.2	Installing Serial ATA hard disks	4-2
4.1.3	Intel® Rapid Storage Technology in UEFI BIOS	4-2
4.1.4	Intel® Rapid Storage Technology Option ROM utility	4-6
<b>4.2</b>	<b>Creating a RAID driver disk</b>	<b>4-10</b>
4.2.1	Creating a RAID driver disk in Windows®	4-10
 <b>Appendix</b>		
<b>Notices</b>		<b>A-1</b>
<b>ASUS contact information</b>		<b>A-6</b>

# Safety information

## Electrical safety

- To prevent electrical shock hazard, disconnect the power cable from the electrical outlet before relocating the system.
- When adding or removing devices to or from the system, ensure that the power cables for the devices are unplugged before the signal cables are connected. If possible, disconnect all power cables from the existing system before you add a device.
- Before connecting or removing signal cables from the motherboard, ensure that all power cables are unplugged.
- Seek professional assistance before using an adapter or extension cord. These devices could interrupt the grounding circuit.
- Ensure that your power supply is set to the correct voltage in your area. If you are not sure about the voltage of the electrical outlet you are using, contact your local power company.
- If the power supply is broken, do not try to fix it by yourself. Contact a qualified service technician or your retailer.

## Operation safety

- Before installing the motherboard and adding devices on it, carefully read all the manuals that came with the package.
- Before using the product, ensure all cables are correctly connected and the power cables are not damaged. If you detect any damage, contact your dealer immediately.
- To avoid short circuits, keep paper clips, screws, and staples away from connectors, slots, sockets and circuitry.
- Avoid dust, humidity, and temperature extremes. Do not place the product in any area where it may become wet.
- Place the product on a stable surface.
- If you encounter technical problems with the product, contact a qualified service technician or your retailer.

## About this guide

This user guide contains the information you need when installing and configuring the motherboard.

## How this guide is organized

This guide contains the following parts:

### 1. Chapter 1: Product Introduction

This chapter describes the features of the motherboard and the new technology it supports. It includes description of the switches, jumpers, and connectors on the motherboard.

### 2. Chapter 2: Basic Installation

This chapter lists the hardware setup procedures that you have to perform when installing system components.

### 3. Chapter 3: BIOS Setup

This chapter tells how to change system settings through the BIOS Setup menus. Detailed descriptions of the BIOS parameters are also provided.

### 4. Chapter 4: RAID Support

This chapter describes the RAID configurations.

## Where to find more information

Refer to the following sources for additional information and for product and software updates.

### 1. ASUS website

The ASUS website ([www.asus.com](http://www.asus.com)) provides updated information on ASUS hardware and software products.

### 2. Optional documentation

Your product package may include optional documentation, such as warranty flyers that may have been added by your dealer. These documents are not part of the standard package.

## Conventions used in this guide

To ensure that you perform certain tasks properly, take note of the following symbols used throughout this manual.



**DANGER/WARNING:** Information to prevent injury to yourself when trying to complete a task.



**CAUTION:** Information to prevent damage to the components when trying to complete a task.



**IMPORTANT:** Instructions that you **MUST** follow to complete a task.



**NOTE:** Tips and additional information to help you complete a task.

## Typography

**Bold text**

Indicates a menu or an item to select.

*Italics*

Used to emphasize a word or a phrase.

<Key>

Keys enclosed in the less-than and greater-than sign means that you must press the enclosed key.

Example: <Enter> means that you must press the Enter or Return key.

<Key1> + <Key2> + <Key3>

If you must press two or more keys simultaneously, the key names are linked with a plus sign (+).

## STRIX X99 GAMING specifications summary

<b>CPU</b>	<p>New Intel® Core™ i7 X-Series Processors on LGA 2011-v3 Socket</p> <p>Supports 14nm CPU</p> <p>Supports Intel® Turbo Boost Max Technology 3.0*</p> <p>* <b>The support of these features depends on the CPU types.</b></p>
<b>Chipset</b>	Intel® X99 Chipset
<b>Memory</b>	<p>8 x DIMM DDR4 max at 128 GB</p> <p>3333 (O.C.)* / 3300 (O.C.)* / 3000 (O.C.)* / 2800 (O.C.)* / 2666 (O.C.)* / 2400 (O.C.)* / 2133 MHz, non-ECC unbuffered memory</p> <p>Quad channel memory architecture</p> <p>Supports Intel® Extreme Memory Profile (XMP)</p> <p>* <b>Hyper DIMM support is subject to the physical characteristics of individual CPUs. Please refer to Memory QVL (Qualified Vendors Lists) on <a href="http://www.asus.com">www.asus.com</a> for details.</b></p>
<b>Expansion Slots</b>	<p>3 x PCI Express 3.0/2.0 x16 slots (support x16, x16/x16, x8/x16/x8 mode with 40-LANE CPU; x16, x16/x8, x8/x8/x8 mode with 28-LANE CPU)*</p> <p>1 x PCI Express 2.0 x16 slot (max. at x4 mode)**</p> <p>2 x PCI Express 2.0 x1 slot***</p> <p>* <b>The PCIEX16_2 slot supports x8 devices only with 28-LANE CPU.</b></p> <p>** <b>The PCIEX4_1, PCIEX1_2, and USB3.1_EC1EA2 connectors share the same bandwidth. By default, the PCIEX4_1 slot and PCIEX1_2 slot automatically run at x1 mode with USB3.1_EC1 and USB3.1_EA2 enabled for best resource optimization.</b></p> <p>*** <b>PCIEX1_1 slot shares bandwidth with WI-FI port at back panel.</b></p>
<b>Multi-GPU Support</b>	<p>Supports NVIDIA® 3-Way/2-Way SLI® Technology</p> <p>Supports AMD® 3-Way/2-Way CrossFireX™ Technology</p>
<b>Storage</b>	<p><b>New Intel® Core™ i7 X-Series Processors</b></p> <ul style="list-style-type: none"> <li>- 1 x M.2 Socket 3 with M Key, type 2242/2260/2280/22110 storage devices support (supports PCIe SSDs only)*</li> <li>- 1 x U.2 port (supports PCIe 3.0 x4 NVM Express storage)*</li> </ul> <p>* <b>The M.2 slot shares bandwidth with U.2 slot.</b></p> <p><b>Intel® X99 Chipset</b></p> <ul style="list-style-type: none"> <li>- 1 x SATA Express port, compatible with 2 x SATA 6Gb/s ports</li> <li>- 8 x SATA 6Gb/s ports</li> <li>- Supports Intel® Smart Response Technology, Intel® Rapid Recovery Technology*</li> </ul> <p>* <b>These functions will work depending on the CPU installed.</b></p>
<b>LAN</b>	<p>Intel® I218-V Gigabit LAN-Dual interconnect between the integrated Media Access Controller (MAC) and physical layer (PHY)</p> <p>Anti-surge LANGuard</p> <p>ROG GameFirst technology</p>

(continued on the next page)

## STRIX X99 GAMING specifications summary

Wireless & Bluetooth	<p>Wi-Fi 802.11 a/b/g/n/ac supports dual frequency band 2.4/5 GHz with MU-MIMO support</p> <p>Bluetooth v4.1, 4.0LE, 3.0+HS</p>
Audio	<p><b>SupremeFX 8-Channel High Definition Audio CODEC</b></p> <ul style="list-style-type: none"> <li>- SupremeFX Shielding Technology</li> <li>- Dual Headphone Amplifiers</li> <li>- Jack-detection, Multi-streaming, and Front Panel Jack-retasking</li> </ul> <p><b>Audio Features</b></p> <ul style="list-style-type: none"> <li>- Sonic Radar II</li> </ul>
USB	<p><b>Intel® X99 Chipset - supports ASUS USB 3.0 Boost</b></p> <ul style="list-style-type: none"> <li>- 5 x USB 3.0 ports (1 port at back panel [blue], 4 ports at mid-board)</li> <li>- 8 x USB 2.0 ports (4 ports at back panel, 4 ports at mid-board)*</li> </ul> <p><b>ASMedia® USB 3.0 controller - supports ASUS USB 3.0 Boost</b></p> <ul style="list-style-type: none"> <li>- 3 x USB 3.0 ports at back panel [blue]</li> </ul> <p><b>ASMedia® USB 3.1 controller - supports ASUS USB 3.1 Boost</b></p> <ul style="list-style-type: none"> <li>- 2 x USB 3.1 ports (1 x Type-A [red] and 1 x Type-C ports at back panel)**</li> </ul> <p>* 2 x USB 2.0 ports at mid-board share with ROG extension (ROG_EXT) port.</p> <p>** USB3.1_EC1 and USB3.1_EA2 ports at back panel will be disabled when the PCIe4_1 slot is occupied by a X4 bandwidth device.</p>
ROG Exclusive Features	<p>ROG RAMCache</p> <p>ROG CPU-Z</p>
Special Features	<p><b>Media Streamer</b></p> <p><b>ASUS Exclusive Features</b></p> <ul style="list-style-type: none"> <li>- Ai Suite 3</li> <li>- USB 3.1 Boost</li> <li>- Ai Charger+</li> <li>- Push Notice</li> <li>- Disk Unlocker</li> </ul> <p><b>ASUS EZ DIY</b></p> <ul style="list-style-type: none"> <li>- USB BIOS Flashback</li> <li>- ASUS CrashFree BIOS 3</li> <li>- ASUS EZ Flash 3</li> <li>- MemOK!</li> </ul> <p><b>ASUS Q-Design</b></p> <ul style="list-style-type: none"> <li>- Q-Code</li> <li>- Q-Shield</li> <li>- Q-Connector</li> <li>- Q-LED (CPU, DRAM, VGA, Boot Device LED)</li> <li>- Q-Slot</li> <li>- Q-DIMM</li> </ul>

(continued on the next page)

## STRIX X99 GAMING specifications summary

<p><b>Back I/O Ports</b></p>	<ul style="list-style-type: none"> <li>1 x USB BIOS Flashback button</li> <li>1 x PS/2 keyboard/mouse combo port</li> <li>4 x USB 2.0 ports</li> <li>4 x USB 3.0 ports [blue]</li> <li>2 x USB 3.1 ports (1 x Type-A [red] and 1 x Type-C ports)</li> <li>1 x Anti-surge LAN (RJ45) port</li> <li>1 x ASUS Wi-Fi GO! module (Wi-Fi 802.11 a/b/g/n/ac and Bluetooth v4.1)</li> <li>5 x Audio jacks</li> </ul>
<p><b>Internal I/O Ports</b></p>	<ul style="list-style-type: none"> <li>2 x USB 3.0 connectors support additional 4 USB 3.0 ports</li> <li>2 x USB 2.0 connectors support additional 4 USB 2.0 ports (one connector via ROG_EXT header)</li> <li>1 x SATA Express connector (compatible with 2 x SATA 6Gb/s ports)</li> <li>8 x SATA 6.0 Gb/s connectors</li> <li>1 x ROG extension (ROG_EXT) header</li> <li>1 x 4-pin Water pump connector</li> <li>1 x 4-pin H_AMP fan connector</li> <li>1 x 4-pin CPU fan connector</li> <li>1 x 4-pin CPU_OPT fan connector</li> <li>2 x 4-pin Chassis fan connectors</li> <li>1 x 5-pin Extension fan connector</li> <li>1 x 24-pin EATX power connector</li> <li>1 x 8-pin EATX 12V power connector</li> <li>1 x 4-pin EATX 12V power connector</li> <li>1 x Power-on button</li> <li>1 x Reset button</li> <li>1 x MemOK! button</li> <li>1 x M.2 Socket 3 for M Key, type 2242/2260/2280/22110 storage devices support (supports PCIE SSD only)</li> <li>1 x U.2 port (supports PCIe 3.0 x4 NVM Express storage)</li> <li>1 x 5-pin Thunderbolt header for ASUS ThunderboltEX III series support</li> <li>1 x Front panel audio connector (AAFP)</li> <li>1 x COM connector</li> <li>1 x RGB header</li> <li>1 x TPM connector</li> <li>1 x System panel connector</li> <li>1 x Thermal sensor connector</li> <li>1 x CPU OverVoltage (OV) header</li> <li>1 x DirectKey (DRCT) connector</li> <li>1 x 2-pin Clear CMOS jumper</li> <li>1 x XMP switch</li> </ul>

*(continued on the next page)*

# STRIX X99 GAMING specifications summary

<b>BIOS Features</b>	128 Mb Flash ROM, UEFI AMI BIOS, PnP, WfM 2.0, SM BIOS 3.0, ACPI 5.0, Multi-language BIOS, ASUS EZ Flash 2, CrashFree BIOS 3, F11 EZ Tuning Wizard, F6 Qfan Control, F3 My Favorites, Quick Note, Last Modified Log, F12 PrintScreen function, F3 Shortcut function, and ASUS DRAM SPD (Serial Presence Detect) memory information
<b>Manageability</b>	WfM 2.0, WOL by PME, PXE
<b>Software</b>	Drivers Anti-virus software (OEM version) ASUS Utilities
<b>Operating System</b>	Windows® 10* Windows® 8.1 Windows® 7 * <b>64-bit supported only.</b>
<b>Form Factors</b>	ATX Form Factor, 12 in. x 9.6 in. (30.5 cm x 24.4 cm)



---

The specifications are subject to change without notice.

---



## Package contents

Check your motherboard package for the following items:

Motherboard	STRIX X99 GAMING
Cables	2 x 2-in-1 SATA 6 Gb/s cables 1 x SLI® cable 1 x 80 cm RGB LED extension cable
Accessories	1 x I/O Shield 1 x 1-in-1 Q-Connector kit 1 x CPU installation tool for Broadwell-E CPU 1 x ASUS 2T2R dual band Wi-Fi moving antennas (Wi-Fi 802.11 a/b/g/n/ac compliant) 1 x ROG cable label 1 x ROG fan label 1 x M.2 screw package 1 x Pack of cable ties 1 x Pack of customizable color decals
Application DVD	ROG motherboard support DVD
Documentation	User guide



If any of the above items is damaged or missing, contact your retailer.

# Installation tools and components

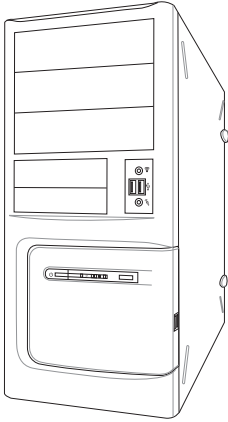

PC chassis

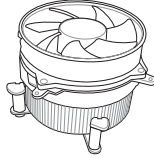

Intel® LGA2011-v3 compatible CPU Fan

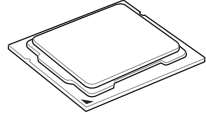

Intel® LGA2011-v3 CPU

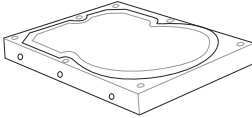

SATA hard disk drive



Philips (cross) screwdriver

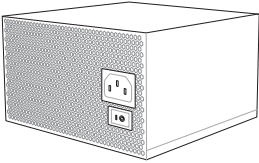

Power supply unit

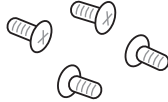

1 bag of screws

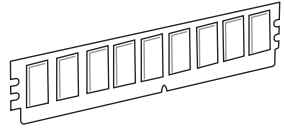

DIMM

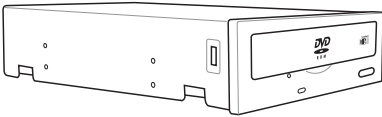

SATA optical disc drive (optional)

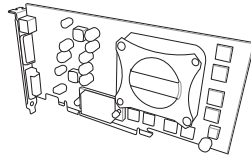

Graphics card



---

The tools and components in the table above are not included in the motherboard package.

---

# Product Introduction

## 1.1 Motherboard overview

### 1.1.1 Before you proceed

Take note of the following precautions before you install motherboard components or change any motherboard settings.



- 
- Unplug the power cord from the wall socket before touching any component.
  - Before handling components, use a grounded wrist strap or touch a safely grounded object or a metal object, such as the power supply case, to avoid damaging them due to static electricity.
  - Hold components by the edges to avoid touching the ICs on them.
  - Whenever you uninstall any component, place it on a grounded antistatic pad or in the bag that came with the component.
  - Before you install or remove any component, ensure that the ATX power supply is switched off or the power cord is detached from the power supply. Failure to do so may cause severe damage to the motherboard, peripherals, or components.
-

## 1.1.2 Motherboard layout

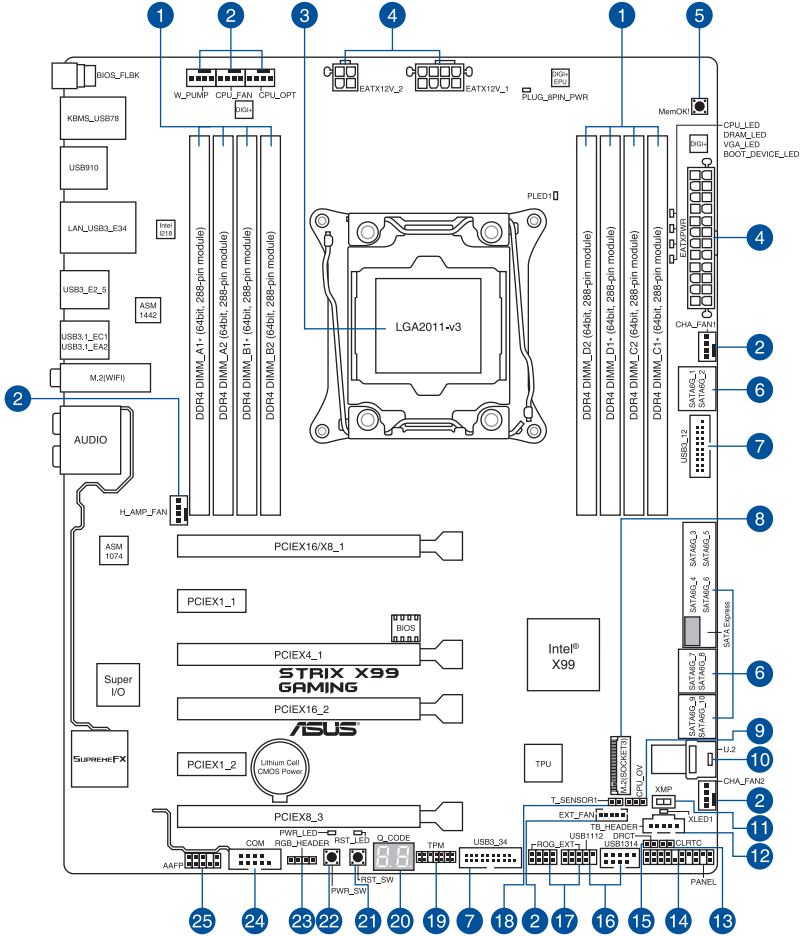

Refer to [1.1.9 Internal connectors](#) and [2.3.1 Rear I/O connection](#) for more information about rear panel connectors and internal connectors.

## Layout contents

Connectors/Jumpers/Buttons and switches/Slots	Page
1. DDR4 DIMM slots	1-5
2. CPU, CPU optional, water pump, high amp, extension, and chassis fan connectors (4-pin CPU_FAN; 4-pin CPU_OPT; 4-pin W_PUMP; 4-pin H_AMP_FAN; 5-pin EXT_FAN; 4-pin CHA_FAN1-2)	1-26
3. LGA2011-v3 CPU socket	1-4
4. ATX power connectors (24-pin EATXPWR; 8-pin EATX12V_1; 4-pin EATX12V_2)	1-27
5. MemOK! button	1-11
6. Intel® Serial ATA 6Gb/s connectors (7-pin SATA6G_12, SATA6G_34, SATA6G_56/SATAEXPRESS, SATA6G_78, SATA6G_910)	1-22
7. USB 3.0 connectors (20-1 pin USB3_12, USB3_34)	1-24
8. M.2 Socket 3	1-23
9. CPU Over Voltage jumper (3-pin CPU_OV)	1-14
10. U.2 connector	1-23
11. EZ XMP switch	1-12
12. Thunderbolt header (5-pin TB_HEADER)	1-30
13. Clear RTC RAM jumper (2-pin CLRRTC)	1-13
14. System panel connector (20-3 pin PANEL)	1-28
15. DirectKey connector (2-pin DRCT)	1-29
16. USB 2.0 connectors (10-1 pin USB1112, USB1314)	1-25
17. ROG Extension connector (18-1 pin ROG_EXT)	1-32
18. T_Sensor connector (2-pin T_SENSOR1)	1-30
19. TPM connector (14-1 pin TPM)	1-29
20. Q-Code LEDs	1-17
21. Reset button	1-10
22. Power-on button	1-10
23. RGB header (4-pin RGB_HEADER)	1-31
24. Serial port connector (10-1 pin COM)	1-32
25. Front panel audio connector (10-1 pin AAFP)	1-33

### 1.1.3 Central Processing Unit (CPU)

The motherboard comes with a surface mount LGA2011-v3 socket designed for Intel® Core™ i7 processors.

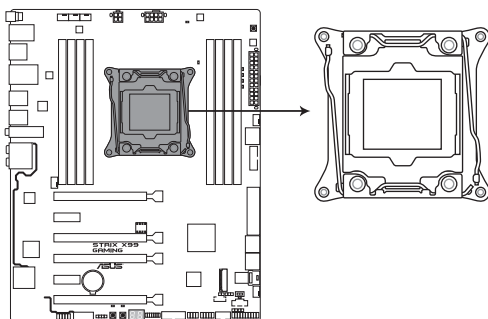

**STRIX X99 GAMING CPU LGA2011-v3 Socket**



- 
- Ensure that all power cables are unplugged before installing the CPU.
  - Upon purchase of the motherboard, ensure that the PnP cap is on the socket and the socket contacts are not bent. Contact your retailer immediately if the PnP cap is missing, or if you see any damage to the PnP cap/socket contacts/motherboard components. ASUS will shoulder the cost of repair only if the damage is shipment/transit-related.
  - Keep the cap after installing the motherboard. ASUS will process Return Merchandise Authorization (RMA) requests only if the motherboard comes with the cap on the LGA2011-v3 socket.
  - The product warranty does not cover damage to the socket contacts resulting from incorrect CPU installation/removal, or misplacement/loss/incorrect removal of the PnP cap.
-

## 1.1.4 System memory

The motherboard comes with eight (8) DDR4 (Double Data Rate 4) Quad Inline Memory Modules (DIMM) slots.



A DDR4 module is notched differently from a DDR, DDR2, or DDR3 module. Do NOT install a DDR, DDR2, or DDR3 memory module to the DDR4 slot.



Ensure to install at least one of the memory modules into the A1+/B1+/C1+/D1+ slot.

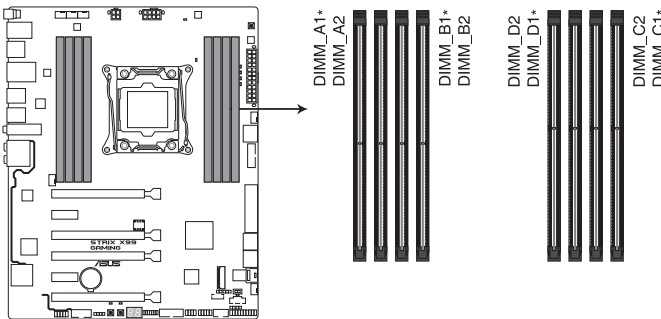

STRIX X99 GAMING 288-pin DDR4 DIMM socket

### Recommended memory configurations

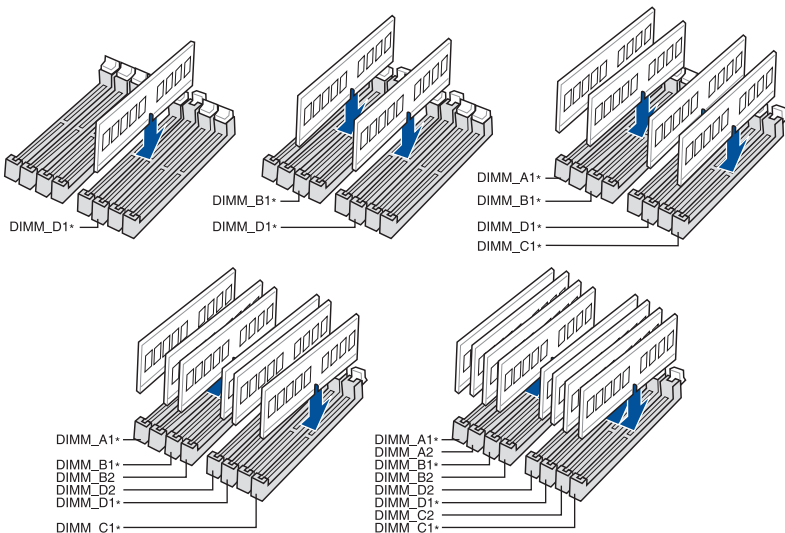



- 
- Side(s): SS - Single-sided    DS - Double-sided DIMM support:
    - 1 Supports one (1) module inserted into any slot as single-channel memory configuration. We suggest that you install the module into D1\* slot.
    - 2 Supports two (2) modules inserted into one pair of the slots as quad-channel memory configuration. We suggest that you install the modules into slots B1\* and D1\* for better compatibility.
    - 4 Supports four (4) modules inserted into two pairs of the slots as quad-channel memory configuration. We suggest that you install the modules into slots A1\*, B1\*, C1\*, and D1\* for better compatibility.
    - 6 Supports six (6) modules inserted into the slots as three pairs of quad-channel memory configuration. We suggest that you install the modules into slots A1\*, B1\*, B2\*, C1\*, D1\*, and D2\* for better compatibility.
    - 8 Supports eight (8) modules inserted into all slots as fully-loaded quad-channel memory configurations.
- 



- ASUS exclusively provides hyper DIMM support function.
  - Hyper DIMM support is subject to the physical characteristics of individual CPUs. Load the X.M.P. or D.O.C.P. settings in the BIOS for the hyper DIMM support.
  - Visit the ASUS website for the latest QVL.
-



## Memory configurations

You may install 2 GB, 4 GB and 8 GB unbuffered and non-ECC DDR4 DIMMs into the DIMM sockets.



- 
- You may install varying memory sizes in Channel A, Channel B, Channel C, and Channel D. The system maps the total size of the lower-sized channel for the quad-channel configuration. Any excess memory from the higher-sized channel is then mapped for single-channel operation.
  - According to Intel® CPU spec, DIMM voltage below 1.65 V is recommended to protect the CPU.
  - Due to the memory address limitation on 32-bit Windows® OS, when you install 4GB or more memory on the motherboard, the actual usable memory for the OS can be about 3GB or less. For effective use of memory, we recommend that you do any of the following:
    - a) Use a maximum of 3GB system memory if you are using a 32-bit Windows® OS.
    - b) Install a 64-bit Windows® OS when you want to install 4 GB or more on the motherboard.
    - c) For more details, refer to the Microsoft® support site at <http://support.microsoft.com/kb/929605/en-us>.
- 



- 
- The default memory operation frequency is dependent on its Serial Presence Detect (SPD), which is the standard way of accessing information from a memory module. Under the default state, some memory modules for overclocking may operate at a lower frequency than the vendor-marked value. To operate at the vendor-marked or at a higher frequency, refer to section **3.5 Ai Tweaker menu** for manual memory frequency adjustment.
  - For system stability, use a more efficient memory cooling system to support a full memory load (8 DIMMs) or overclocking condition.
  - Always install the DIMMs with the same CAS Latency. For an optimum compatibility, we recommend that you install memory modules of the same version or data code (D/C) from the same vendor. Check with the vendor to get the correct memory modules.
  - The design of the DIMM fan may vary. Ensure that the DIMM fan fits to the motherboard.
-

## 1.1.5 Expansion slots



Unplug the power cord before adding or removing expansion cards. Failure to do so may cause you physical injury and damage motherboard components.

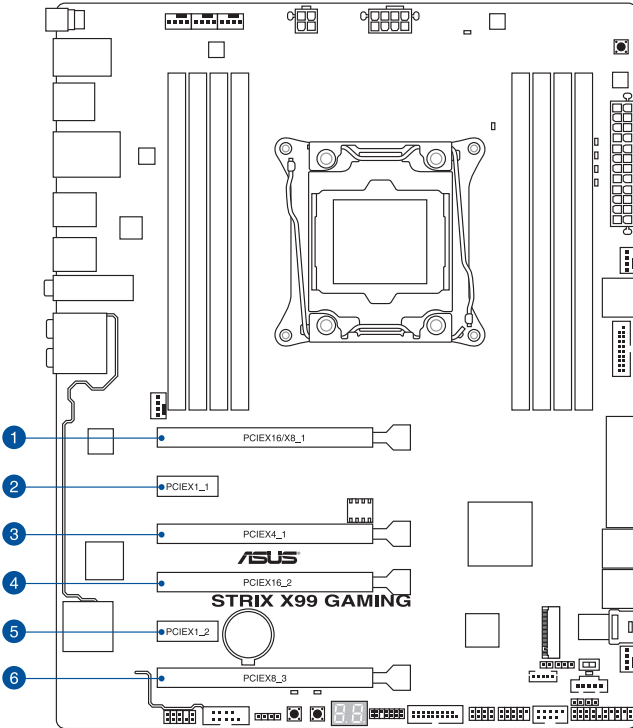

40-LANE CPU	PCI Express 3.0 operating mode		
	VGA configuration	PCIEX16/X8_1	PCIEX16_2
Single VGA/PCIe card	x16 (single VGA recommended)	N/A	N/A
Dual VGA/PCIe cards	x16	x16	N/A
Triple VGA/PCIe cards	x8	x16	x8

28-LANE CPU	PCI Express 3.0 operating mode		
	VGA configuration	PCIEX16/X8_1	PCIEX16_2
Single VGA/PCIe card	x16 (single VGA recommended)	N/A	N/A
Dual VGA/PCIe cards	x16	x8	N/A
Triple VGA/PCIe cards	x8	x8	x8



- We recommend that you provide sufficient power when running CrossFireX™ or SLI® mode.
- Connect a chassis fan to the motherboard connector labeled CHA\_FAN1-2 when using multiple graphics cards for better thermal environment.
- PCIEX4\_1 is set to x1 mode by default.
- Wi-Fi Controller/PCIEX1\_1 is set to **[Enabled]** by default. Set this item in BIOS to **[Disabled]** to enable auto detection of PCIEX1\_1 device.
- If the x1 device is not detected on PCIEX8\_3 slot, set the PCIEX8\_3 Slot Bandwidth item in BIOS to **[X8 Mode]**. Refer to section 3.6.7 **Onboard Devices Configuration** for details.

## 1.1.6 Onboard buttons and switches

Onboard buttons and switches allow you to fine-tune performance when working on a bare or open-case system. This is ideal for overclockers and gamers who continually change settings to enhance system performance.

### 1. Power-on button

The motherboard comes with a power-on button that allows you to power up or wake up the system. The LED near the button also lights up when the system is plugged to a power source indicating that you should shut down the system and unplug the power cable before removing or installing any motherboard component.

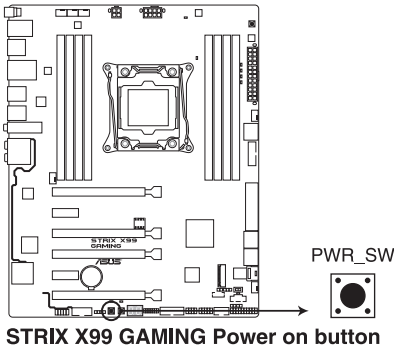

---

Refer to section 1.1.8 Onboard LEDs for the exact location of the PWR\_LED.

---

### 2. Reset button

Press the reset button to reboot the system.

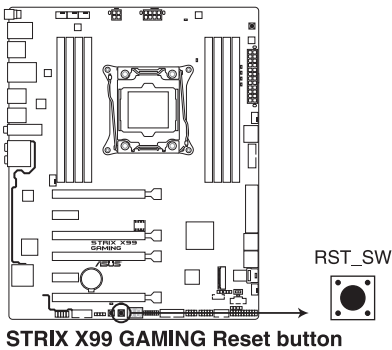

### 3. MemOK! button

Installing DIMMs that are not compatible with the motherboard may cause system boot failure. If the system fails to boot during POST stage and the DRAM\_LED near the MemOK! button lights continuously, press the MemOK! button until the DRAM\_LED starts blinking. System will begin automatic memory compatibility tuning and reboot for successful boot.

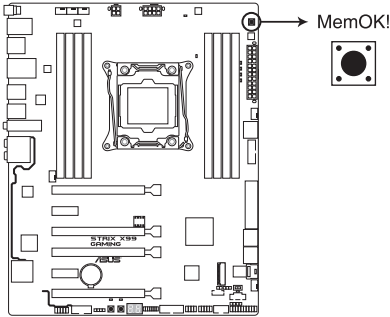

**STRIX X99 GAMING MemOK! button**



- Refer to section **1.1.8 Onboard LEDs** for the exact location of the DRAM\_LED.
- The DRAM\_LED also lights up when the DIMM is not properly installed. Turn off the system and reinstall the DIMM before using the MemOK! function.
- The MemOK! button does not function under Windows® OS environment.
- During the tuning process, the system loads and tests failsafe memory settings. It takes about 30 seconds for the system to test one set of failsafe settings. If the test fails, the system reboots and tests the next set of failsafe settings. The blinking speed of the DRAM\_LED increases, indicating different test processes.
- Due to memory tuning requirement, the system automatically reboots when each timing set is tested. If the installed DIMMs still fail to boot after the whole tuning process, the DRAM\_LED lights continuously. Replace the DIMMs with ones recommended in the Memory QVL (Qualified Vendors Lists) in this user manual or at [www.asus.com](http://www.asus.com).
- If you turn off the computer and replace DIMMs during the tuning process, the system continues memory tuning after turning on the computer. To stop memory tuning, turn off the computer and unplug the power cord for about 5–10 seconds.
- If your system fails to boot up due to BIOS overlocking, press the MemOK! button to boot and load the BIOS default settings. A message will appear during POST reminding you that the BIOS has been restored to its default settings.
- We recommend that you download and update to the latest BIOS version from [www.asus.com](http://www.asus.com) after using the MemOK! function.

#### 4. EZ XMP switch

Enable this switch to overclock the installed DIMMs, allowing you to enhance the DIMM's speed and performance.

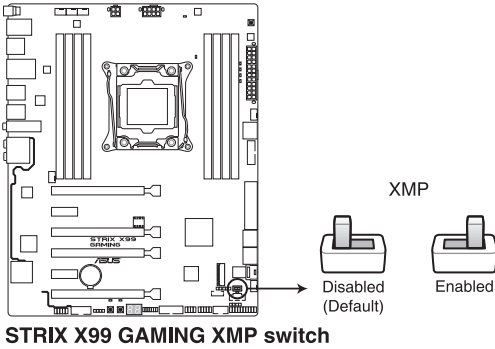

---

The EZ XMP LED (XLED1) lights up when you enable the EZ XMP switch. Refer to section **1.1.8 Onboard LEDs** for the exact location of the XLED1.

---

## 1.1.7 Jumpers

### 1. Clear RTC RAM jumper (2-pin CLRRTC)

This jumper allows you to clear the Real Time Clock (RTC) RAM in CMOS. You can clear the CMOS memory of date, time, and system setup parameters by erasing the CMOS RTC RAM data. The onboard button cell battery powers the RAM data in CMOS, which includes system setup information such as system passwords.

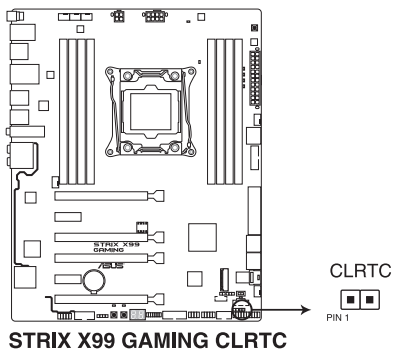

To erase the RTC RAM:

1. Turn OFF the computer and unplug the power cord.
2. Short-circuit pin 1-2 with a metal object for about 5-10 seconds.
3. Plug the power cord and turn ON the computer.
4. Hold down the <Delete> key during the boot process and enter BIOS setup to re-enter data.



Except when clearing the RTC RAM, never remove the cap on CLRRTC jumper default position. Removing the cap will cause system boot failure!



- If the steps above do not help, remove the onboard battery and move the jumper again to clear the CMOS RTC RAM data. After the CMOS clearance, reinstall the battery.
- You do not need to clear the RTC when the system hangs due to overclocking. For system failure due to overclocking, use the C.P.R. (CPU Parameter Recall) feature. Shut down and reboot the system so the BIOS can automatically reset parameter settings to default values.
- Due to the chipset behavior, AC power off is required to enable C.P.R. function. You must turn off and on the power supply or unplug and plug the power cord before rebooting the system.

**2. CPU Over Voltage jumper (3-pin CPU\_OV)**

The CPU Over Voltage jumper allows you to set a higher CPU voltage for a flexible overclocking system, depending on the type of the installed CPU. To gain more CPU voltage setting, insert the jumper to pins 2-3. To go back to its default CPU voltage setting, insert the jumper to pins 1-2.

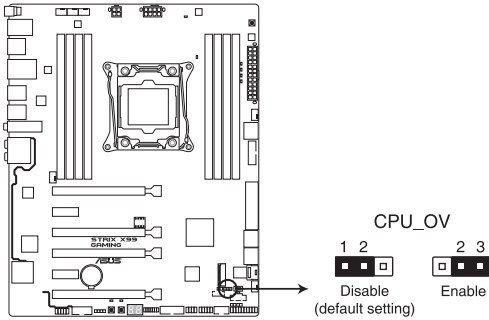

**STRIX X99 GAMING CPU\_OV setting**



## 1.1.8 Onboard LEDs

### 1. POST State LEDs

The POST State LEDs provide the status of these key components during POST (Power-On Self-Test): CPU, memory modules, VGA card, and hard disk drives. If an error is found, the critical component's LED stays lit up until the problem is solved.

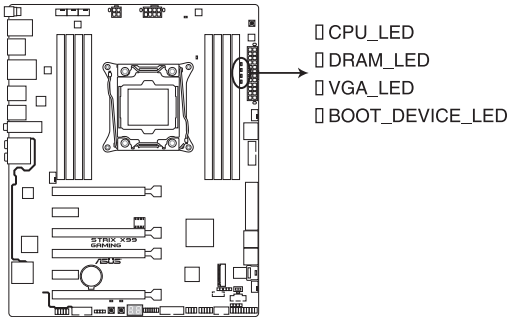

**STRIX X99 GAMING CPU/ DRAM/  
BOOT\_DEVICE/ VGA LED**

### 2. EZ XMP LED (XLED1)

This LED lights up when you enable the EZ XMP switch.

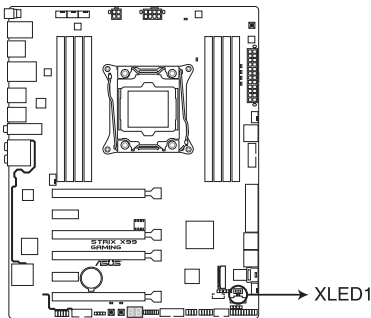

**STRIX X99 GAMING XLED1**

### 3. Standby Power LED (PWR\_LED)

The motherboard comes with a standby power LED that lights up to indicate that the system is ON, in sleep mode, or in soft-off mode. This is a reminder that you should shut down the system and unplug the power cable before removing or plugging any motherboard components. The illustration below shows the location of the onboard LED.

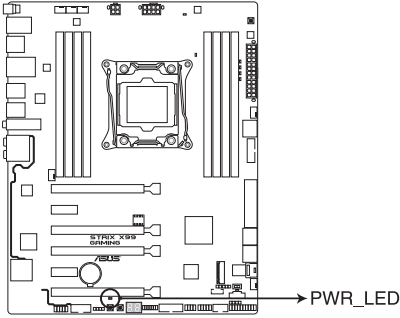

**STRIX X99 GAMING PWR\_LED**

### 4. PCIE LEDs

The PCIE LEDs light up to indicate the PCIe slots that share lane with the CPU.

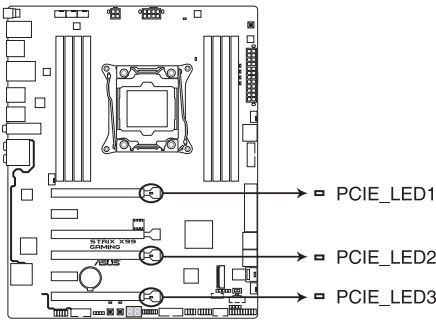

**STRIX X99 GAMING PCIE LEDs**



---

PCIEX4\_1 slot will not light up as it shares lane with the PCH controller.

---

## 5. Q-Code LED

The Q-Code LED design provides you with a 2-digit error code that displays the system status. Refer to the Q-Code table below for details.

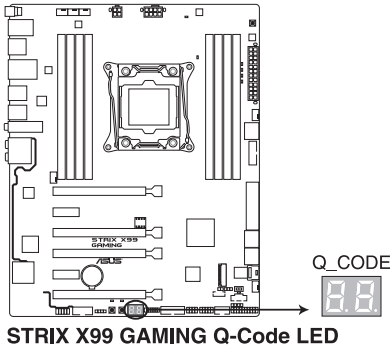

## Q-Code table

Code	Description
00	Not used
01	Power on. Reset type detection (soft/hard).
02	AP initialization before microcode loading
03	System Agent initialization before microcode loading
04	PCH initialization before microcode loading
06	Microcode loading
07	AP initialization after microcode loading
08	System Agent initialization after microcode loading
09	PCH initialization after microcode loading
0B	Cache initialization
0C – 0D	Reserved for future AMI SEC error codes
0E	Microcode not found
0F	Microcode not loaded
10	PEI Core is started
11 – 14	Pre-memory CPU initialization is started
15 – 18	Pre-memory System Agent initialization is started
19 – 1C	Pre-memory PCH initialization is started
2B – 2F	Memory initialization
30	Reserved for ASL (see ASL Status Codes section below)
31	Memory Installed
32 – 36	CPU post-memory initialization
37 – 3A	Post-Memory System Agent initialization is started
3B – 3E	Post-Memory PCH initialization is started
4F	DXE IPL is started
50 – 53	Memory initialization error. Invalid memory type or incompatible memory speed
54	Unspecified memory initialization error
55	Memory not installed
56	Invalid CPU type or Speed
57	CPU mismatch
58	CPU self test failed or possible CPU cache error
59	CPU micro-code is not found or micro-code update is failed

*(continued on the next page)*

## Q-Code table

Code	Description
5A	Internal CPU error
5B	Reset PPI is not available
5C – 5F	Reserved for future AMI error codes
E0	S3 Resume is started (S3 Resume PPI is called by the DXE IPL)
E1	S3 Boot Script execution
E2	Video repost
E3	OS S3 wake vector call
E4 – E7	Reserved for future AMI progress codes
E8	S3 Resume Failed
E9	S3 Resume PPI not Found
EA	S3 Resume Boot Script Error
EB	S3 OS Wake Error
EC – EF	Reserved for future AMI error codes
F0	Recovery condition triggered by firmware (Auto recovery)
F1	Recovery condition triggered by user (Forced recovery)
F2	Recovery process started
F3	Recovery firmware image is found
F4	Recovery firmware image is loaded
F5 – F7	Reserved for future AMI progress codes
F8	Recovery PPI is not available
F9	Recovery capsule is not found
FA	Invalid recovery capsule
FB – FF	Reserved for future AMI error codes
60	DXE Core is started
61	NVRAM initialization
62	Installation of the PCH Runtime Services
63 – 67	CPU DXE initialization is started
68	PCI host bridge initialization
69	System Agent DXE initialization is started
6A	System Agent DXE SMM initialization is started
6B – 6F	System Agent DXE initialization (System Agent module specific)

*(continued on the next page)*

## Q-Code table

Code	Description
70	PCH DXE initialization is started
71	PCH DXE SMM initialization is started
72	PCH devices initialization
73 – 77	PCH DXE Initialization (PCH module specific)
78	ACPI module initialization
79	CSM initialization
7A – 7F	Reserved for future AMI DXE codes
90	Boot Device Selection (BDS) phase is started
91	Driver connecting is started
92	PCI Bus initialization is started
93	PCI Bus Hot Plug Controller Initialization
94	PCI Bus Enumeration
95	PCI Bus Request Resources
96	PCI Bus Assign Resources
97	Console Output devices connect
98	Console input devices connect
99	Super IO Initialization
9A	USB initialization is started
9B	USB Reset
9C	USB Detect
9D	USB Enable
9E – 9F	Reserved for future AMI codes
A0	IDE initialization is started
A1	IDE Reset
A2	IDE Detect
A3	IDE Enable
A4	SCSI initialization is started
A5	SCSI Reset
A6	SCSI Detect
A7	SCSI Enable
A8	Setup Verifying Password

*(continued on the next page)*

## Q-Code table

Code	Description
A9	Start of Setup
AA	Reserved for ASL (see ASL Status Codes section below)
AB	Setup Input Wait
AC	Reserved for ASL (see ASL Status Codes section below)
AD	Ready To Boot event
AE	Legacy Boot event
AF	Exit Boot Services event
B0	Runtime Set Virtual Address MAP Begin
B1	Runtime Set Virtual Address MAP End
B2	Legacy Option ROM Initialization
B3	System Reset
B4	USB hot plug
B5	PCI bus hot plug
B6	Clean-up of NVRAM
B7	Configuration Reset (reset of NVRAM settings)
B8– BF	Reserved for future AML codes
D0	CPU initialization error
D1	System Agent initialization error
D2	PCH initialization error
D3	Some of the Architectural Protocols are not available
D4	PCI resource allocation error. Out of Resources
D5	No Space for Legacy Option ROM
D6	No Console Output Devices are found
D7	No Console Input Devices are found
D8	Invalid password
D9	Error loading Boot Option (LoadImage returned error)
DA	Boot Option is failed (StartImage returned error)
DB	Flash update is failed
DC	Reset protocol is not available

## 1.1.9 Internal connectors

### 1. Intel® X99 Serial ATA 6Gb/s connectors (7-pin SATA6G\_12, SATA6G\_34, SATA6G\_56/SATAEXPRESS, SATA6G\_78, SATA6G\_910)

These connectors connect to Serial ATA 6Gb/s hard disk drives via Serial ATA 6Gb/s signal cables.

If you installed Serial ATA hard disk drives, you can create a RAID 0, 1, 5, and 10 configuration with the Intel® Rapid Storage Technology through the onboard Intel® X99 chipset.

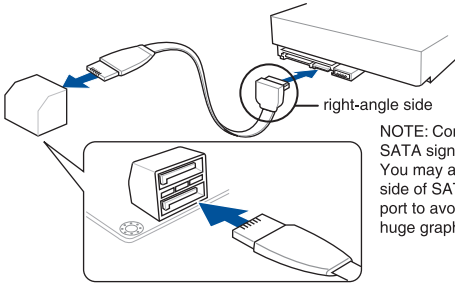
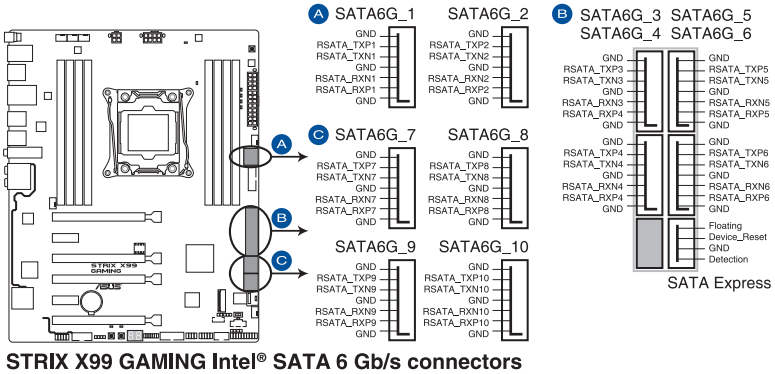

NOTE: Connect the right-angle side of SATA signal cable to SATA device. You may also connect the right-angle side of SATA cable to the onboard SATA port to avoid mechanical conflict with huge graphics cards.



- These connectors are set to **[AHCI Mode]** by default. If you intend to create a Serial ATA RAID set using these connectors, set the SATA Mode item in the BIOS to **[RAID Mode]**. Refer to section 3.6.3 PCH Storage Configuration for details.
- Before creating a RAID set, refer to the manual bundled in the motherboard support DVD.



- The SATAEXPRESS connector can support one SATA Express device or two SATA devices.
- Due to chipset behavior, the SATA6G\_78 and SATA6G\_910 ports do not support Intel® Rapid Storage Technology and RAID configuration.



## 2. M.2 socket 3

This socket allows you to install an M.2 (NGFF) SSD module.

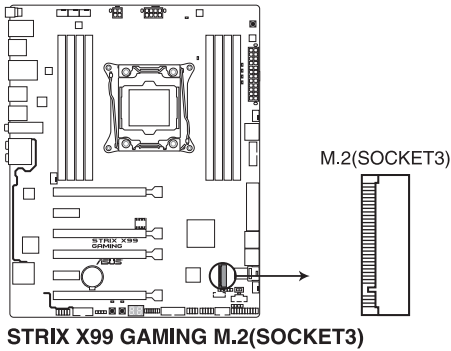

- This socket supports M Key and type 2242/2260/2280/22110 storage devices.
- The M.2 connector shares bandwidth with U.2 connector.

## 3. U.2 connector (U.2)

This motherboard comes with a U.2 connector which supports PCIe 3.0 x4 NVM Express storage.

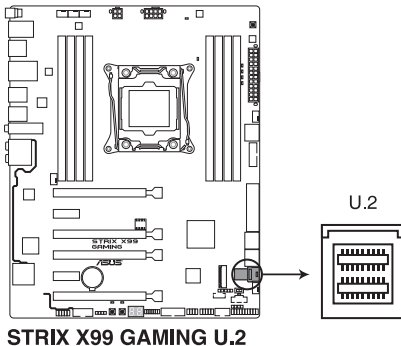

The U.2 connector shares bandwidth with M.2 connector.

#### 4. USB 3.0 connectors (20-pin USB3\_12, USB3\_34)

These connectors allow you to connect a USB 3.0 module for additional USB 3.0 front or rear panel ports. With an installed USB 3.0 module, you can enjoy all the benefits of USB 3.0 including faster data transfer speeds of up to 5Gb/s, faster charging time for USB-chargeable devices, optimized power efficiency, and backward compatibility with USB 2.0.

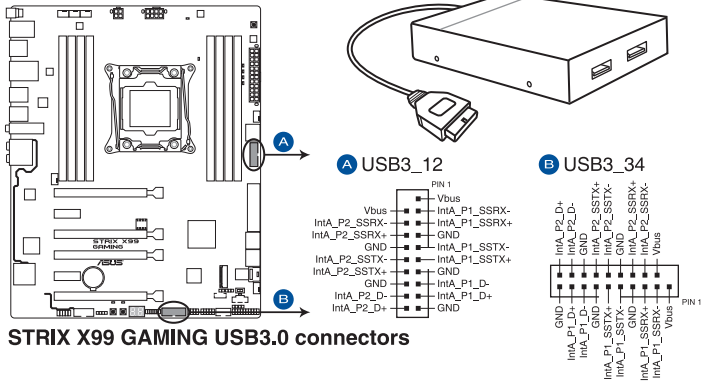

**STRIX X99 GAMING USB3.0 connectors**



The USB 3.0 module is purchased separately.



- Ensure to install the related driver to fully use the USB 3.0 ports under Windows® 7.
- The plugged USB 3.0 device may run on xHCI or EHCI mode depending on the operating system's setting.
- These USB 3.0 ports support native UASP transfer standard in Windows® 8 / Windows® 8.1 and Turbo Mode when using USB 3.0 Boost feature.

## 5. USB 2.0 connectors (10-1 pin USB1112; USB1314)

These connectors are for USB 2.0 ports. Connect the USB module cable to any of these connectors, then install the module to a slot opening at the back of the system chassis. These USB connectors comply with USB 2.0 specification that supports up to 480Mb/s connection speed.

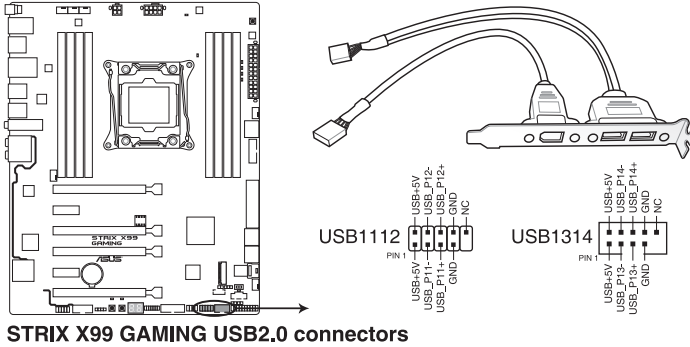

DO NOT connect a 1394 cable to the USB connectors. Doing so will damage the motherboard!



- You can connect the front panel USB cable to the ASUS Q-Connector (USB) first, and then install the Q-Connector (USB) to the USB connector onboard if your chassis supports front panel USB ports.
- 1 x USB 2.0 port (USB1112) at mid-board shares with ROG extension (ROG\_EXT) port.



The USB 2.0 module is purchased separately.

6. CPU, CPU optional, water pump, high amp, extension, and chassis fan connectors (4-pin CPU\_FAN; 4-pin CPU\_OPT; 4-pin W\_PUMP; 4-pin H\_AMP\_FAN; 5-pin EXT\_FAN; 4-pin CHA\_FAN1-2)

Connect the fan cables to the fan connectors on the motherboard, ensuring that the black wire of each cable matches the ground pin of the connector.



- DO NOT forget to connect the fan cables to the fan connectors. Insufficient air flow inside the system may damage the motherboard components. These are not jumpers! Do not place jumper caps on the fan connectors!
- Ensure that the CPU fan cable is securely installed to the CPU fan connector.

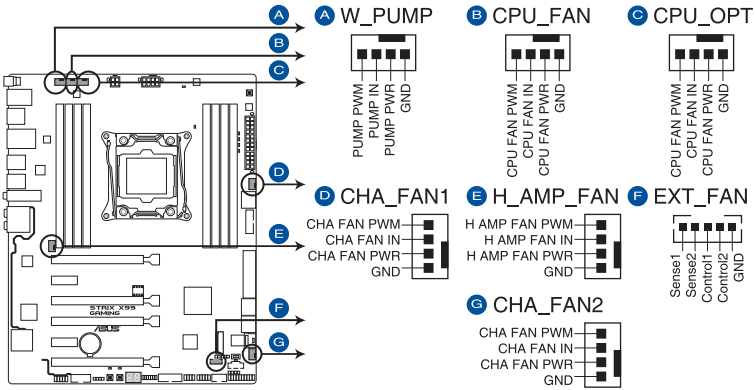

STRIX X99 GAMING Fan connectors



- The CPU\_FAN connector supports the CPU fan of maximum 1A (12W) fan power.
- The CPU\_FAN, CHA\_FAN, and EXT\_FAN connectors support the ASUS FAN Xpert 3 feature on X99 platform.
- The EXT\_FAN connector supports 2 of 5 thermal sensor sources.
- The CPU fan connector detects the type of CPU fan installed and automatically switches the control modes. To configure the CPU fan's control mode, go to **Advanced Mode > Monitor > CPU Q-Fan Control** item in BIOS.
- The chassis fan connectors support DC and PWM modes. To set these fans to DC or PWM, go to **Advanced Mode > Monitor > Chassis Fan 1/2 Q-Fan Control** items in BIOS.



The FAN EXTENSION CARD is purchased separately.

## 7. ATX power connectors (24-pin EATXPWR; 8-pin EATX12V\_1; 4-pin EATX12V\_2)

These connectors are for ATX power supply plugs. The power supply plugs are designed to fit these connectors in only one orientation. Find the proper orientation and push down firmly until the connectors completely fit.

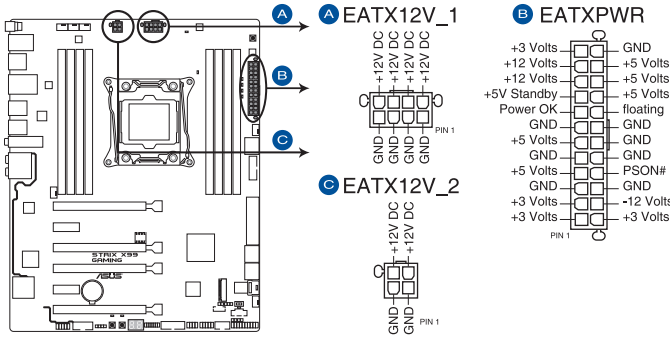

**STRIX X99 GAMING ATX power connectors**



- For a fully configured system, we recommend that you use a power supply unit (PSU) that complies with ATX 12V Specification 2.0 (or later version) and provides a minimum power of 350W.
- DO NOT forget to connect the 4-pin/8-pin EATX12V power plug. Otherwise, the system will not boot.
- We recommend that you use a PSU with a higher power output when configuring a system with more power-consuming devices. The system may become unstable or may not boot up if the power is inadequate.
- If you want to use two or more high-end PCI Express x16 cards, use a PSU with 1000W power or above to ensure the system stability.

## 8. System panel connector (20-3 pin PANEL)

This connector supports several chassis-mounted functions.

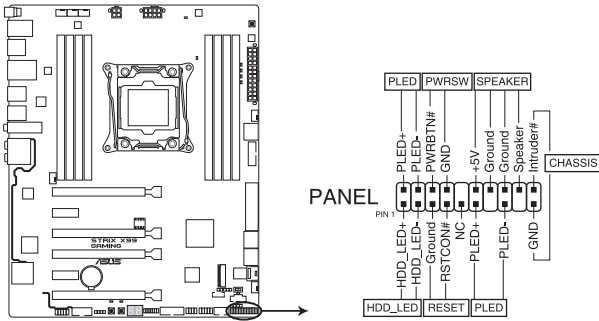

**STRIX X99 GAMING System panel connector**

- **System power LED (2-pin or 3-1 pin PLED)**

The 2-pin or 3-1 pin connector is for the system power LED. Connect the chassis power LED cable to this connector. The system power LED lights up when you turn on the system power, and blinks when the system is in sleep mode.

- **Hard disk drive activity LED (2-pin HDD\_LED)**

This 2-pin connector is for the HDD Activity LED. Connect the HDD Activity LED cable to this connector. The HDD LED lights up or flashes when data is read from or written to the HDD.

- **System warning speaker (4-pin SPEAKER)**

This 4-pin connector is for the chassis-mounted system warning speaker. The speaker allows you to hear system beeps and warnings.

- **ATX power button/soft-off button (2-pin PWRSW)**

This connector is for the system power button. Pressing the power button turns the system on or puts the system in sleep or soft-off mode depending on the operating system settings. Pressing the power switch for more than four seconds while the system is ON turns the system OFF.

- **Reset button (2-pin RESET)**

This 2-pin connector is for the chassis-mounted reset button for system reboot without turning off the system power.

- **Chassis intrusion connector (2-pin CHASSIS)**

This connector is for a chassis-mounted intrusion detection sensor or switch. Connect one end of the chassis intrusion sensor or switch cable to this connector. The chassis intrusion sensor or switch sends a high-level signal to this connector when a chassis component is removed or replaced. The signal is then generated as a chassis intrusion event.

## 9. TPM connector (14-1 pin TPM)

This connector supports a Trusted Platform Module (TPM) system, which securely stores keys, digital certificates, passwords and data. A TPM system also helps enhance network security, protect digital identities, and ensures platform integrity.

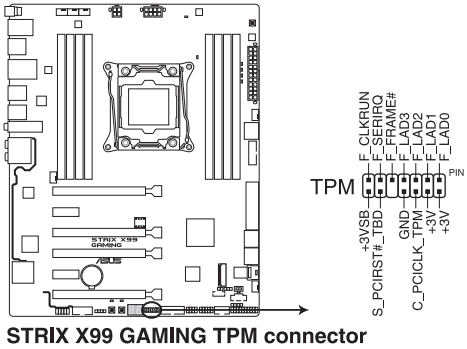

The TPM module is purchased separately.

## 10. DirectKey connector (2-pin DRCT)

This connector is for the chassis-mounted button that supports the DirectKey function. Connect the button cable that supports DirectKey from the chassis to this connector on the motherboard.

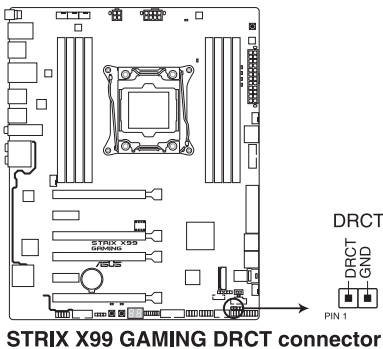

Ensure that your chassis comes with the extra button cable that supports the DirectKey feature. Refer to the technical documentation that came with the chassis for details.

### 11. Thunderbolt header (5-pin TB\_HEADER)

This connector is for the add-on Thunderbolt I/O card that supports Intel's Thunderbolt Technology, allowing you to connect up to six Thunderbolt-enabled devices and a DisplayPort-enabled display in a daisy-chain configuration.

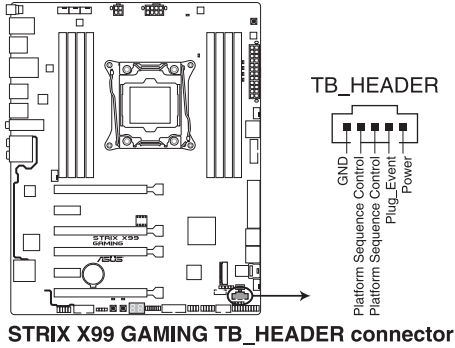

The add-on Thunderbolt I/O card and Thunderbolt cables are purchased separately.

### 12. Thermal Sensor connector (2-pin T\_SENSOR1)

This connector is for the thermistor cable that monitors the temperature of the devices and the critical components inside the motherboard. Connect the thermistor cable and place the sensor on the device or the motherboard's component to detect its temperature.

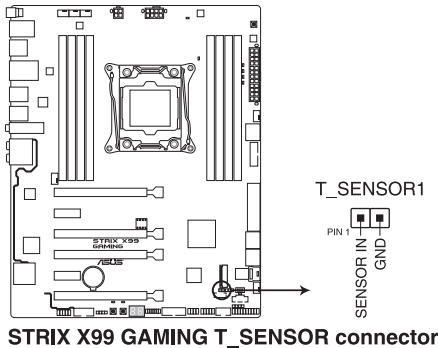

The thermistor cable is purchased separately.



### 13. RGB header (4-pin RGB\_HEADER)

This connector is for RGB LED strips.

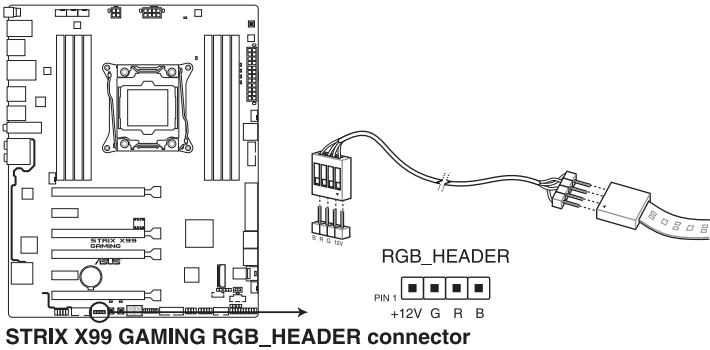

- The RGB header supports 5050 multi-color LED strips (+12V/G/R/B), with a maximum power rating of 2A (12V), and no longer than 2 m.
- Ensure that the RGB LED extension cable and the RGB LED strip is connected in the correct orientation, and the +12V connector is aligned with the +12V header on the motherboard.



Before you install or remove any component, ensure that the ATX power supply is switched off or the power cord is detached from the power supply. Failure to do so may cause severe damage to the motherboard, peripherals, or components.



- Actual lighting and color will vary with LED strip.
- The lighting effects may be customized with the help of AURA software.

#### 14. ROG Extension connector (18-1 pin ROG\_EXT)

This connector is for the OC Panel I/II, Front Base, and other ROG devices.

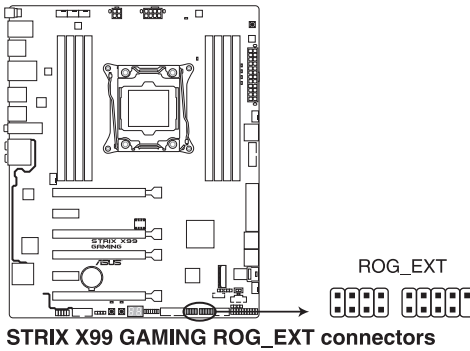

- The Front Base is purchased separately.
- Visit [www.asus.com](http://www.asus.com) for more information about the OC Panel and Front Base.

#### 15. Serial port connector (10-1 pin COM)

These connectors are for the serial (COM) port. Connect the serial port module cable to one of these connectors, then install the module to a slot opening at the back of the system chassis.

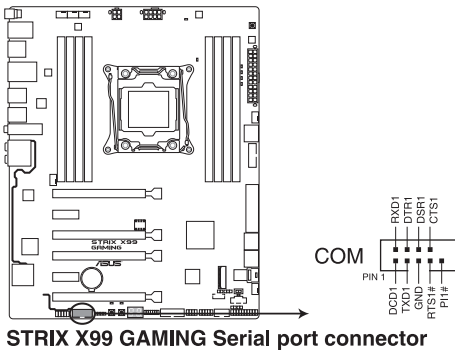

## 16. Front panel audio connector (10-1 pin AAFP)

This connector is for a chassis-mounted front panel audio I/O module that supports either HD Audio or legacy AC'97 audio standard. Connect one end of the front panel audio I/O module cable to this connector.

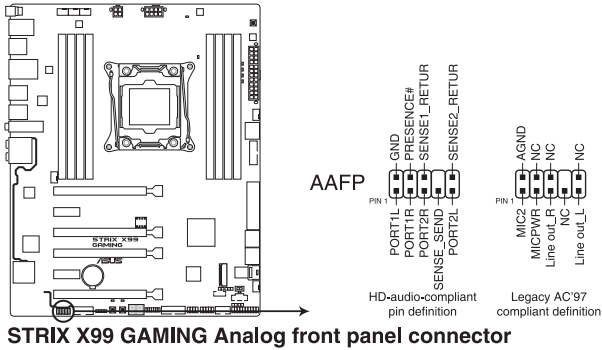

**STRIX X99 GAMING Analog front panel connector**



- We recommend that you connect a high-definition front panel audio module to this connector to avail of the motherboard's high-definition audio capability.
- If you want to connect a high-definition or an AC'97 front panel audio module to this connector, set the Front Panel Type item in the BIOS setup to **[HD]** or **[AC97]**.



# Basic Installation

# 2

## 2.1 Building your PC system

### 2.1.1 Motherboard installation



The diagrams in this section are for references only. The motherboard layout may vary with models, but the installation steps are the same for all models.

1. Install the ASUS Q-Shield to the chassis rear I/O panel.

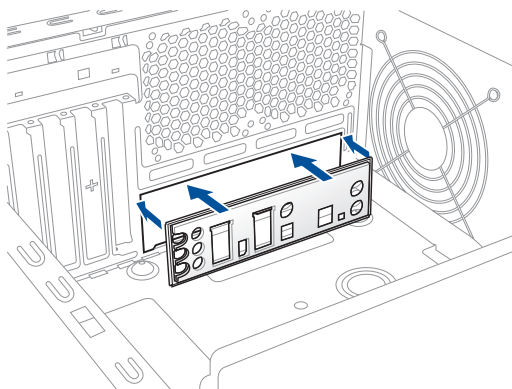

2. Place the motherboard into the chassis, ensuring that its rear I/O ports are aligned to the chassis' rear I/O panel.

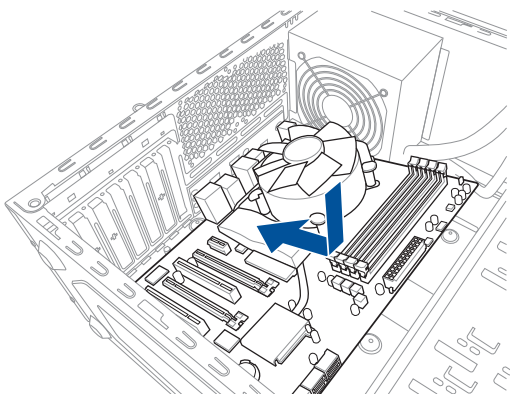

3. Place nine screws into the holes indicated by circles to secure the motherboard to the chassis.

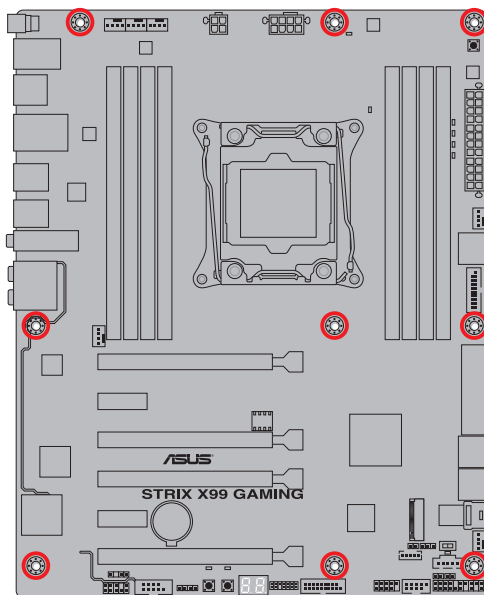
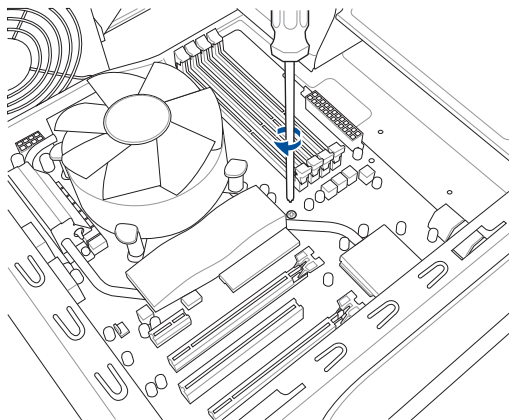

DO NOT overtighten the screws! Doing so can damage the motherboard.

## 2.1.2 CPU installation



Please note the order in opening/closing the double latch. Follow the instructions printed on the metal sealing hatch or the illustrations shown below in this manual. The plastic cap will pop up automatically once the CPU is in place and the hatch properly sealed down.

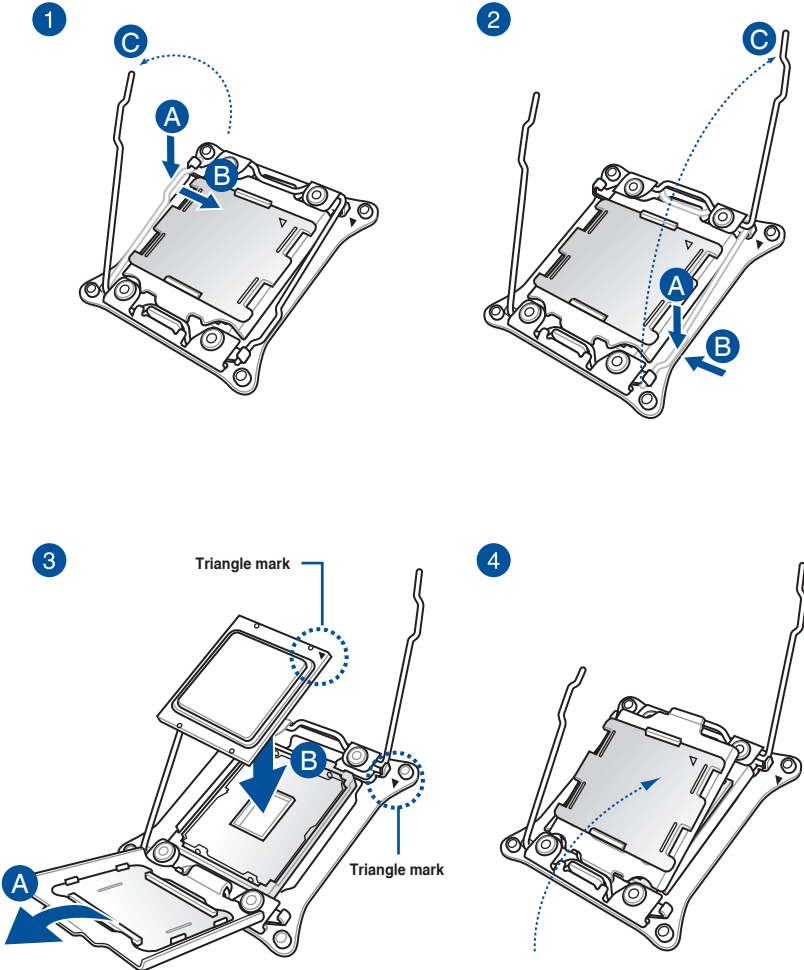

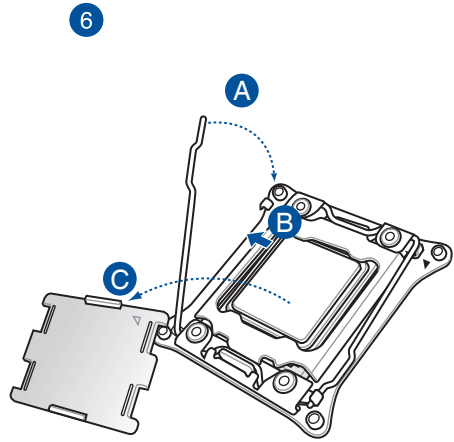
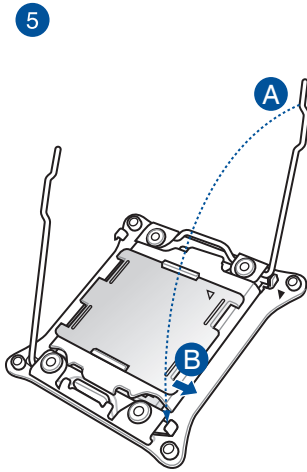

### 2.1.3 CPU heatsink and fan assembly installation

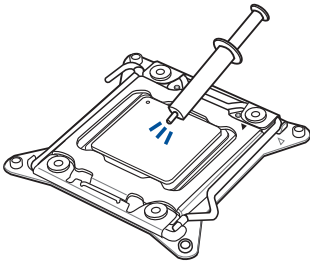

Apply the Thermal Interface Material to the CPU heatsink and CPU before you install the heatsink and fan, if necessary.



To install the CPU heatsink and fan assembly:

1

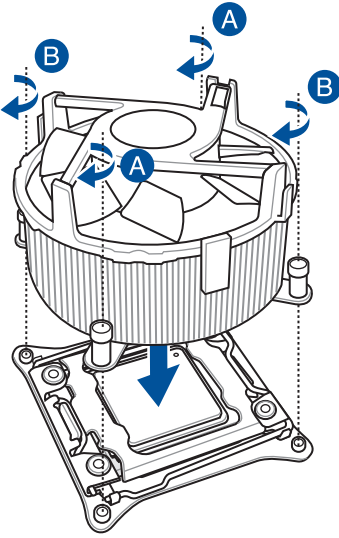

2

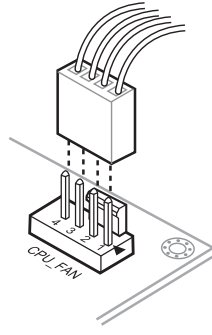

## 2.1.4 DIMM installation



Ensure to install at least one of the memory modules into the A1+/B1+/C1+/D1+ slot.

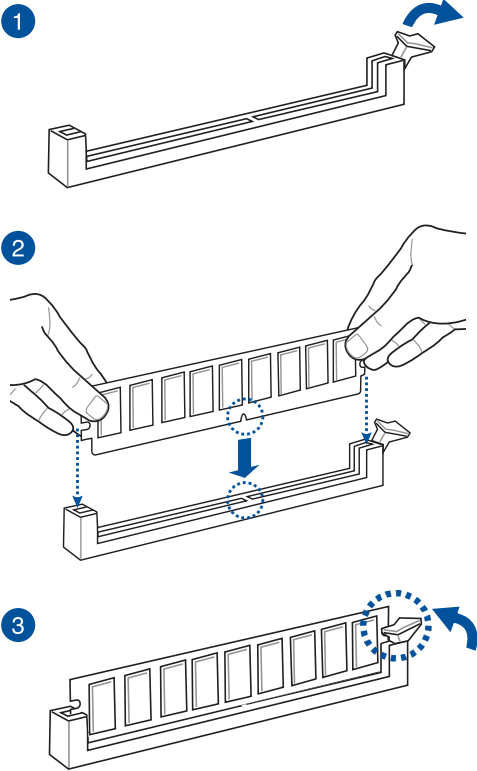

### To remove a DIMM

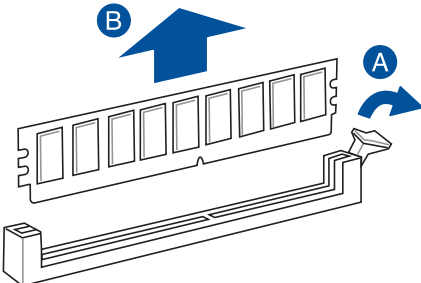

## 2.1.5 ATX Power connection

1

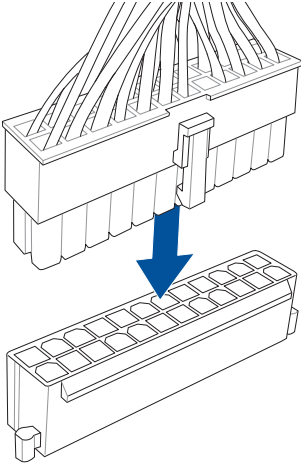

2

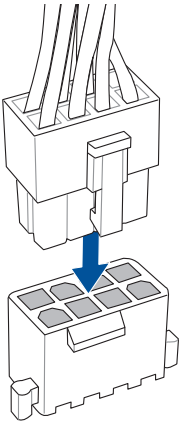

OR

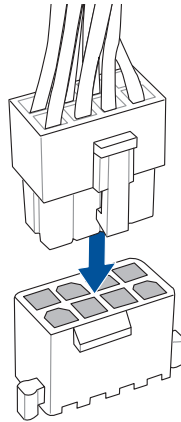

AND

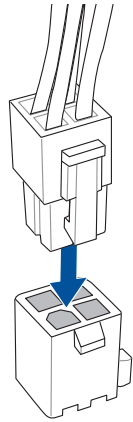

- DO NOT connect the 4-pin power plug only, the motherboard may overheat under heavy usage.
- Ensure to connect the 8-pin power plug, or connect both 8-pin and 4-pin power plugs.

## 2.1.6 SATA device connection

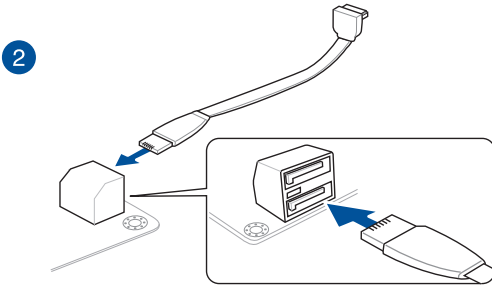
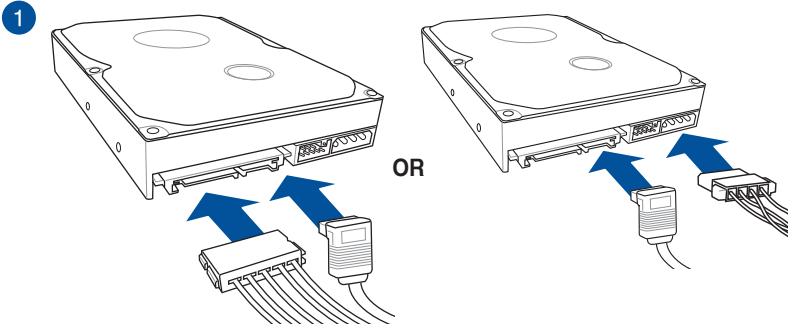

OR

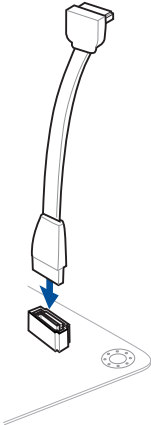

## 2.1.7 Front I/O Connector

To install ASUS Q-Connector

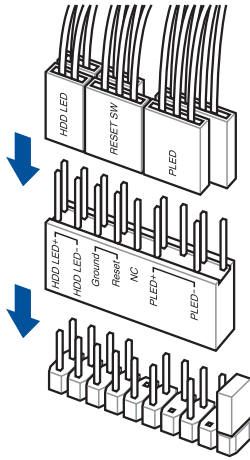

To install front panel audio connector

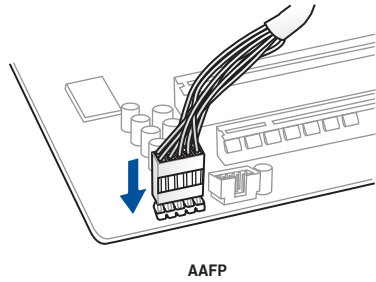

To install USB 2.0 connector

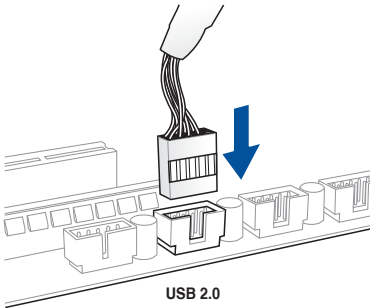

To install USB 3.0 connector

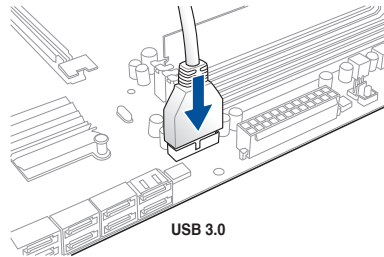

The USB 2.0 and USB 3.0 module are purchased separately.

## 2.1.8 Expansion Card installation

To install PCIe x16 cards

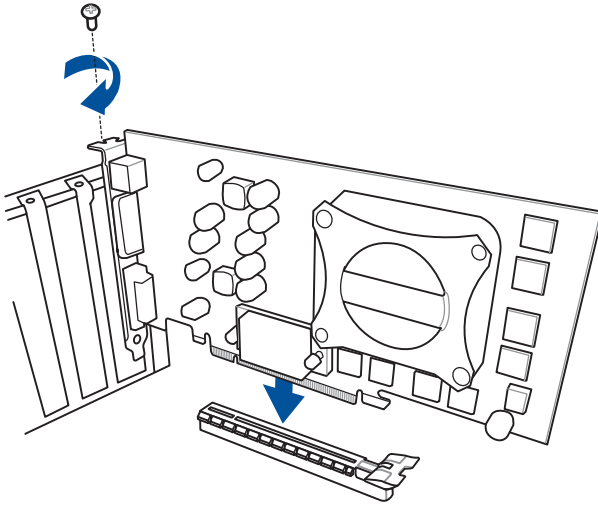

To install PCIe x1 cards

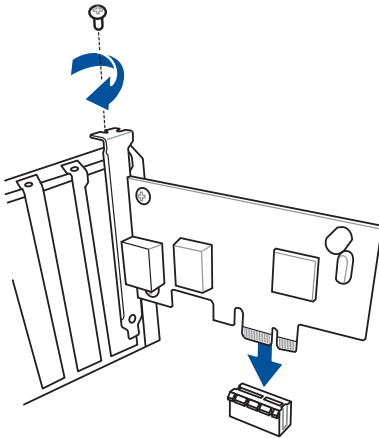

## To install FAN EXTENSION CARD

1

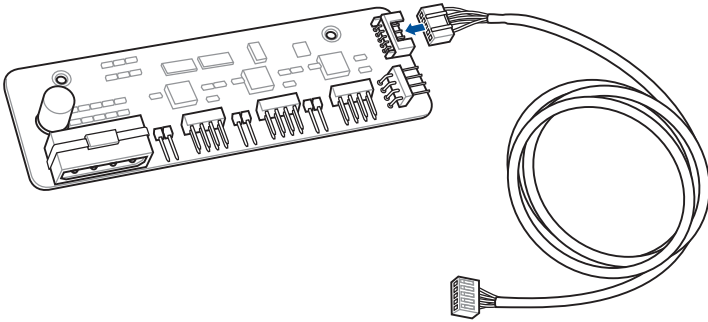

2

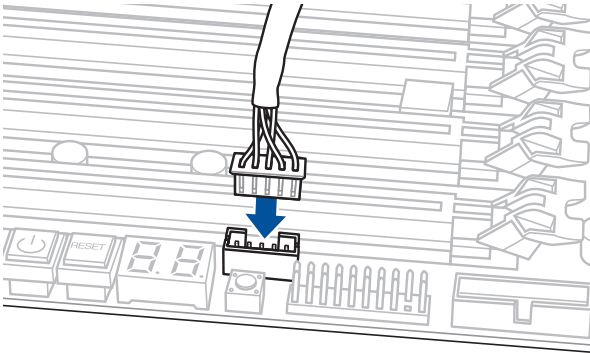

- The illustrations in this section are for reference only. The motherboard layout may vary with models, but the installation steps are the same for all models.
- The FAN Extension card is purchased separately.

## 2.1.9 Wi-Fi antenna installation

### Installing the ASUS 2T2R dual band W-Fi antenna

Connect the bundled ASUS 2T2R dual band Wi-Fi antenna connector to the Wi-Fi ports at the back of the chassis.

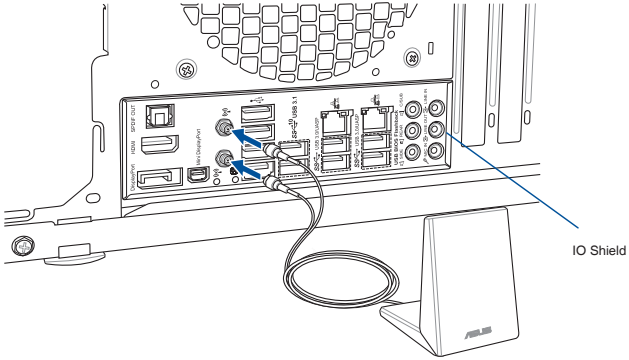

- Ensure that the ASUS 2T2R dual band Wi-Fi antenna is securely installed to the Wi-Fi ports.
- Ensure that the antenna is at least 20 cm away from all persons.



The illustration above is for reference only. The I/O port layout may vary with models, but the Wi-Fi antenna installation procedure is the same for all models.



## 2.2 BIOS update utility

### USB BIOS Flashback

USB BIOS Flashback allows you to easily update the BIOS without entering the existing BIOS or operating system. Simply insert a USB storage device to the USB port (the USB port hole marked in green on the I/O shield) then press the USB BIOS Flashback button for three seconds to automatically update the BIOS.

#### To use USB BIOS Flashback:

1. Place the bundled support DVD to the optical drive and install the USB BIOS Flashback Wizard. Follow the onscreen instructions to complete the installation.
2. Insert the USB storage device to the USB Flashback port.



- We recommend you to use a USB 2.0 storage device to save the latest BIOS version for better compatibility and stability.
- Refer to section **2.3.1 Rear I/O connection** for the location of the USB port that supports USB BIOS Flashback.

3. Launch the USB BIOS Flashback Wizard to automatically download the latest BIOS version.
4. Shut down your computer.
5. Press the BIOS Flashback button for three seconds until the Flashback LED blinks three times, indicating that the BIOS Flashback function is enabled.

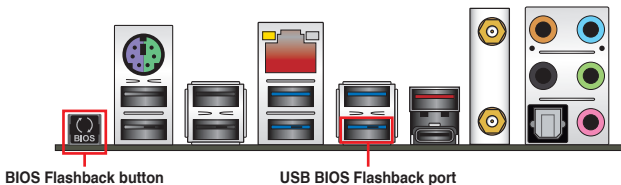

6. Wait until the light goes out, indicating that the BIOS updating process is completed.



For more BIOS update utilities in BIOS setup, refer to the section **3.11 Updating BIOS** in Chapter 3.



- Do not unplug portable disk, power system, or press the CLR\_CMOS button while BIOS update is ongoing, otherwise update will be interrupted. In case of interruption, please follow the steps again.
- If the light flashes for five seconds and turns into a solid light, this means that the BIOS Flashback is not operating properly. This may be caused by improper installation of the USB storage device and filename/file format error. If this scenario happens, please restart the system to turn off the light.
- Updating BIOS may have risks. If the BIOS program is damaged during the process and results to the system's failure to boot up, please contact your local ASUS Service Center.

## 2.3 Motherboard rear and audio connections

### 2.3.1 Rear I/O connection

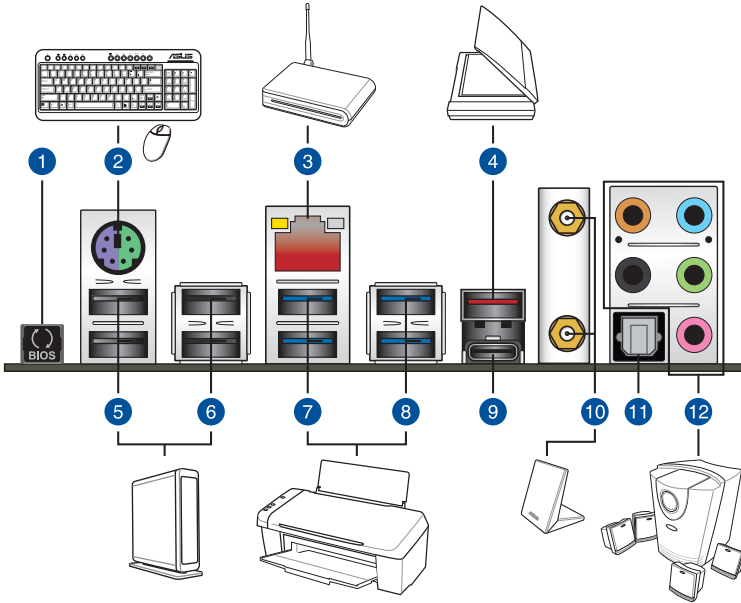

Rear panel connectors	
1. USB BIOS Flashback button	7. USB 3.0 ports E34
2. Keyboard/Mouse combo port	8. USB 3.0 ports E2_5 (Bottom port supports USB BIOS Flashback)
3. Intel® LAN port*	9. USB 3.1 Type-C port EC1
4. USB 3.1 Type-A port EA2	10. Wi-Fi 802.11 a/b/g/n/ac, Bluetooth V4.0*
5. USB 2.0 ports 78	11. Optical S/PDIF Out port
6. USB 2.0 ports 910	12. Audio I/O ports**

\* and \*\*: Refer to the tables on the next page for LAN port LEDs and audio port definitions.



- The plugged USB 3.0 device may run on xHCI mode or EHCI mode, depending on the operating system's setting.
- USB 3.0 devices can only be used as data storage only.
- We strongly recommend that you connect USB 3.0 devices to USB 3.0 ports for faster and better performance for your USB 3.0 devices.
- Due to the design of the Intel® X99 series chipset, all USB devices connected to the USB 2.0 and USB 3.0 ports are controlled by the xHCI controller. Some legacy USB devices must update their firmware for better compatibility.

### \* LAN ports LED indications

Activity Link LED		Speed LED	
Status	Description	Status	Description
Off	No link	Off	10 Mbps connection
Orange	Linked	Orange	100 Mbps connection
Orange (Blinking)	Data activity	Green	1 Gbps connection
Orange (Blinking then steady)	Ready to wake up from S5 mode		

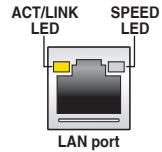

You can disable the LAN controllers in BIOS. Due to hardware design, the LAN port's LEDs may continue to blink even when disabled.

### \*\* Audio 2, 4, 6, or 8-channel configuration

Port	Headset 2-channel	4-channel	6-channel	8-channel
Light Blue	Line In	Line In	Line In	Side Speaker Out
Line	Front Speaker Out	Front Speaker Out	Front Speaker Out	Front Speaker Out
Pink	Mic In	Mic In	Mic In	Mic In
Orange	–	–	Center/Subwoofer	Center/Subwoofer
Black	–	Rear Speaker Out	Rear Speaker Out	Rear Speaker Out

## 2.3.2 Audio I/O connections

### Audio I/O ports

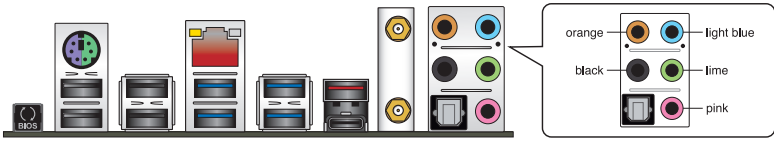

### Connect to Headphone and Mic



### Connect to Stereo Speakers

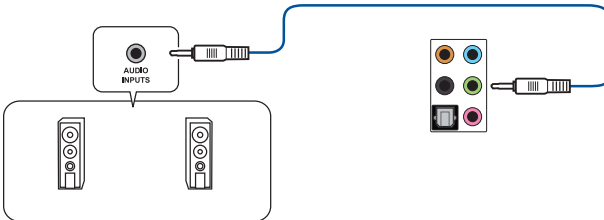

### Connect to 2.1 channel Speakers

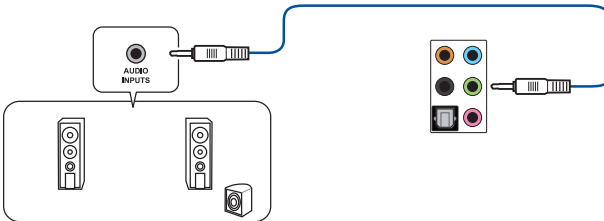

## Connect to 4.1 channel Speakers

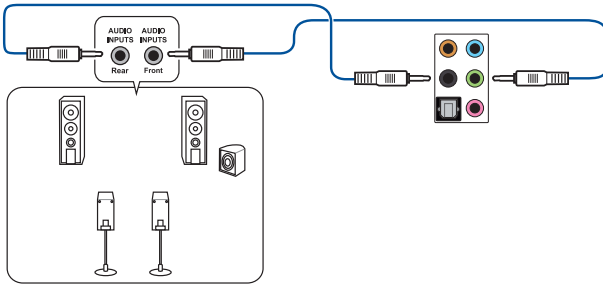

## Connect to 5.1 channel Speakers

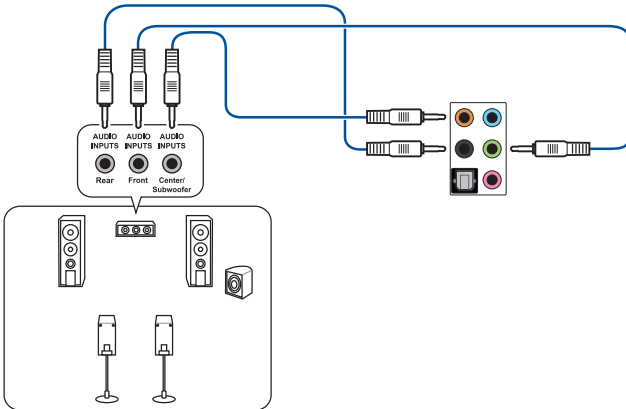

If you are using Windows® 8.1/10 platform, use only the light blue audio port for Side Speaker Out in a 6-channel configuration.

## Connect to 7.1 channel Speakers

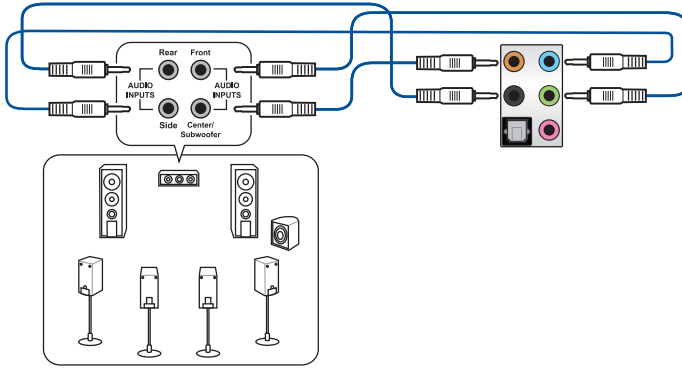

When the DTS UltraPC II function is enabled, ensure to connect the rear speaker to the light blue port.

## 2.4 Starting up for the first time

1. After making all the connections, replace the system case cover.
2. Ensure that all switches are off.
3. Connect the power cord to the power connector at the back of the system chassis.
4. Connect the power cord to a power outlet that is equipped with a surge protector.
5. Turn on the devices in the following order:
  - a. Monitor
  - b. External SCSI devices (starting with the last device on the chain)
  - c. System power
6. After applying power, the system power LED on the system front panel case lights up. For systems with ATX power supplies, the system LED lights up when you press the ATX power button. If your monitor complies with the “green” standards or if it has a “power standby” feature, the monitor LED may light up or change from orange to green after the system LED turns on.

The system then runs the power-on self tests (POST). While the tests are running, the BIOS beeps (refer to the BIOS beep codes table) or additional messages appear on the screen. If you do not see anything within 30 seconds from the time you turned on the power, the system may have failed a power-on test. Check the jumper settings and connections or call your retailer for assistance.

BIOS Beep	Description
One short beep	VGA detected Quick boot set to disabled No keyboard detected
One continuous beep followed by two short beeps then a pause (repeated)	No memory detected
One continuous beep followed by three short beeps	No VGA detected
One continuous beep followed by four short beeps	Hardware component failure

- At power on, hold down the <Delete> key to enter the BIOS Setup. Follow the instructions in Chapter 3.

## 2.5 Turning off the computer

While the system is ON, press the power button for less than four seconds to put the system on sleep mode or soft-off mode, depending on the BIOS setting. Press the power switch for more than four seconds to let the system enter the soft-off mode regardless of the BIOS setting.





# BIOS Setup

# 3

## 3.1 Knowing BIOS



---

The new ASUS UEFI BIOS is a Unified Extensible Interface that complies with UEFI architecture, offering a user-friendly interface that goes beyond the traditional keyboard-only BIOS controls to enable a more flexible and convenient mouse input. You can easily navigate the new UEFI BIOS with the same smoothness as your operating system. The term "BIOS" in this user manual refers to "UEFI BIOS" unless otherwise specified.

---

BIOS (Basic Input and Output System) stores system hardware settings such as storage device configuration, overclocking settings, advanced power management, and boot device configuration that are needed for system startup in the motherboard CMOS. In normal circumstances, the default BIOS settings apply to most conditions to ensure optimal performance. **DO NOT change the default BIOS settings** except in the following circumstances:

- An error message appears on the screen during the system bootup and requests you to run the BIOS Setup.
- You have installed a new system component that requires further BIOS settings or update.



---

Inappropriate BIOS settings may result in instability or boot failure. We strongly recommend that you change the BIOS settings only with the help of a trained service personnel.

---



---

When downloading or updating the BIOS file, rename it as **STXX99.CAP** for this motherboard.

---

## 3.2 BIOS setup program

Use the BIOS Setup to update the BIOS or configure its parameters. The BIOS screen include navigation keys and brief onscreen help to guide you in using the BIOS Setup program.

### Entering BIOS at startup

To enter BIOS Setup at startup, press <Delete> during the Power-On Self Test (POST). If you do not press <Delete>, POST continues with its routines.

### Entering BIOS Setup after POST

To enter BIOS Setup after POST:

- Press <Ctrl>+<Alt>+<Delete> simultaneously.
- Press the reset button on the system chassis.
- Press the power button to turn the system off then back on. Do this option only if you failed to enter BIOS Setup using the first two options.

After doing either of the three options, press <Delete> key to enter BIOS.



- 
- The BIOS setup screens shown in this section are for reference purposes only, and may not exactly match what you see on your screen.
  - Ensure that a USB mouse is connected to your motherboard if you want to use the mouse to control the BIOS setup program.
  - If the system becomes unstable after changing any BIOS setting, load the default settings to ensure system compatibility and stability. Select the **Load Optimized Defaults** item under the **Exit** menu or press hotkey <F5>. See section **3.10 Exit menu** for details.
  - If the system fails to boot after changing any BIOS setting, try to clear the CMOS and reset the motherboard to the default value. See section **1.1.6 Onboard buttons and switches** for information on how to erase the RTC RAM via the Clear CMOS button.
  - The BIOS setup program does not support the Bluetooth devices.
- 

### BIOS menu screen

The BIOS Setup program can be used under two modes: **EZ Mode** and **Advanced Mode**. You can change modes from **Setup Mode** in **Boot** menu or by pressing the <F7> hotkey.

### 3.2.1 EZ Mode

By default, the EZ Mode screen appears when you enter the BIOS setup program. The EZ Mode provides you an overview of the basic system information, and allows you to select the display language, system performance mode and boot device priority. To access the Advanced Mode, select **Advanced Mode** or press <F7> hotkey for the advanced BIOS settings.



The default screen for entering the BIOS setup program can be changed between EZ Mode or Advanced Mode. Refer to the **Setup Mode** item in section 3.8 **Boot menu** for details.

The screenshot shows the UEFI BIOS Utility - EZ Mode interface. The interface is divided into several sections:

- Information:** Displays system properties like date (03/02/2016), time (10:56), language (English), and EZ Tuning Wizard (F11).
- System Properties:** Displays CPU/Motherboard temperature (55°C), CPU voltage output (1.123 V), CPU/chassis/power fan speed (3100 MHz), and SATA information.
- System Tuning:** Allows selecting the display language of the BIOS setup program and creating storage RAID and configuring system overlocking.
- System Tuning Modes:** Offers options for Performance, Quiet, and Energy Saving.
- Boot Priority:** Allows selecting the boot device priority.
- Intel Rapid Storage Technology:** Includes a section for enabling or disabling SATA RAID mode.
- FAN Profile:** Displays CPU Fan's speed (4838 RPM) and allows manual tuning of fans.
- QFan Control:** A graph showing CPU Fan speed vs. temperature, with a QFan Control button.
- Navigation:** Includes buttons for Default (F5), Save & Exit (F10), Advanced Mode (F7), and Search on FAQ.

Annotations on the screenshot include:

- Displays the system properties of the selected mode. Click < > to switch EZ System Tuning modes
- Displays the CPU/Motherboard temperature, CPU voltage output, CPU/chassis/power fan speed, and SATA information
- Selects the display language of the BIOS setup program
- Creates storage RAID and configures system overlocking
- Click the icon to specify your preferred system settings for an improved system performance or a power-saving system environment
- Choose one and drag the items. Switch all
- Enables or disables the SATA RAID mode for Intel Rapid Storage Technology
- Loads optimized default settings
- Click to go to Advanced mode
- Search on the FAQ
- Click to display boot devices
- Selects the boot device priority
- Saves the changes and resets the system
- Displays the CPU Fan's speed. Click the button to manually tune the fans



The boot device options vary depending on the devices you installed to the system.

### 3.2.2 Advanced Mode

The Advanced Mode provides advanced options for experienced end-users to configure the BIOS settings. The figure below shows an example of the Advanced Mode. Refer to the following sections for the detailed configurations.



To switch from EZ Mode to Advanced Mode, click **Advanced Mode(F7)** or press the <F7> hotkey.

The screenshot shows the ASUS UEFI BIOS Advanced Mode interface. The top bar includes the date (03/02/2016), time (14:59), language (English), and various utility shortcuts like MyFavorite(F3), Qfan Control(F6), EZ Tuning Wizard(F11), Quick Note(F9), and Hot Keys. A menu bar at the top lists: My Favorites, Main, Ai Tweaker (highlighted), Advanced, Monitor, Boot, Tool, and Exit. The main area is divided into sections: AI Overclock Tuner (set to Auto), ASUS MultiCore Enhancement, and CPU Core Ratio (with 1-6 Core Ratio Limits). A Hardware Monitor panel on the right displays CPU (3100 MHz, 53°C), BCLK (100.0 MHz), Memory (2133 MHz, 4096 MB), and Voltage (+12V, +5V, +3.3V) information. A scroll bar is visible at the bottom right. A search bar for the FAQ is located at the bottom right. A 'Last Modified' section is at the bottom center. A 'Goes back to EZ Mode' button is at the bottom left. A 'Menu items' label points to the left side of the interface. A 'General help' label points to the bottom left. A 'Last modified settings' label points to the bottom center. A 'Search on the FAQ' label points to the bottom right. A 'Displays the CPU temperature, CPU, and memory voltage output' label points to the Hardware Monitor panel.

## Menu bar

The menu bar on top of the screen has the following main items:

<b>My Favorites</b>	For saving the frequently-used system settings and configuration
<b>Main</b>	For changing the basic system configuration
<b>Ai Tweaker</b>	For changing the overclocking settings
<b>Advanced</b>	For changing the advanced system settings
<b>Monitor</b>	For displaying the system temperature, power status, and changing the fan settings
<b>Boot</b>	For changing the system boot configuration
<b>Tool</b>	For configuring options for special functions
<b>Exit</b>	For selecting the exit options and loading default settings

## Menu items

The highlighted item on the menu bar displays the specific items for that menu. For example, selecting **Main** shows the Main menu items.

The other items (My Favorites, Ai Tweaker, Advanced, Monitor, Boot, Tool, and Exit) on the menu bar have their respective menu items.

## Submenu items

A greater than sign (>) before each item on any menu screen means that the item has a submenu. To display the submenu, select the item and press <Enter>.

## Language

This button above the menu bar contains the languages that you can select for your BIOS. Click this button to select the language that you want to display in your BIOS screen.

## MyFavorite(F3)

This button above the menu bar shows all BIOS items in a Tree Map setup. Select frequently-used BIOS settings and save it to My Favorites menu.



---

Refer to section **3.3 My Favorites** for more information.

---

## Qfan Control(F6)

This button above the menu bar displays the current settings of your fans. Use this button to manually tweak the fans to your desired settings.



---

Refer to section **3.2.3 QFan Control** for more information.

---

## EZ Tuning Wizard (F11)

This button above the menu bar allows you to view and tweak the overclocking settings of your system. It also allows you to change the motherboard's SATA mode from AHCI to RAID mode.



---

Refer to section **3.2.4 EZ Tuning Wizard** for more information.

---

## Quick Note(F9)

This button above the menu bar allows you to key in notes of the activities that you have done in BIOS.



- The Quick Note function does not support the following keyboard functions: delete, cut, copy and paste.
- You can only use the alphanumeric characters to enter your notes.

## Hot Keys

This button above the menu bar contains the navigation keys for the BIOS setup program. Use the navigation keys to select items in the menu and change the settings.

## Scroll bar

A scroll bar appears on the right side of a menu screen when there are items that do not fit on the screen. Press the Up/Down arrow keys or <Page Up> / <Page Down> keys to display the other items on the screen.

## General help

At the bottom of the menu screen is a brief description of the selected item. Use <F12> key to capture the BIOS screen and save it to the removable storage device.

## Configuration fields

These fields show the values for the menu items. If an item is user-configurable, you can change the value of the field opposite the item. You cannot select an item that is not user-configurable.

A configurable field is highlighted when selected. To change the value of a field, select it and press <Enter> to display a list of options.

## Last Modified button

This button shows the items that you last modified and saved in BIOS Setup.

## Search on FAQ

Move your mouse over this button to show a QR code, scan this QR code on your mobile device to connect to the BIOS FAQ web page of the ASUS support website. You can also scan the following QR code:



### 3.2.3 QFan Control

The QFan Control allows you to set a fan profile or manually configure the operating speed of your CPU and chassis fans.

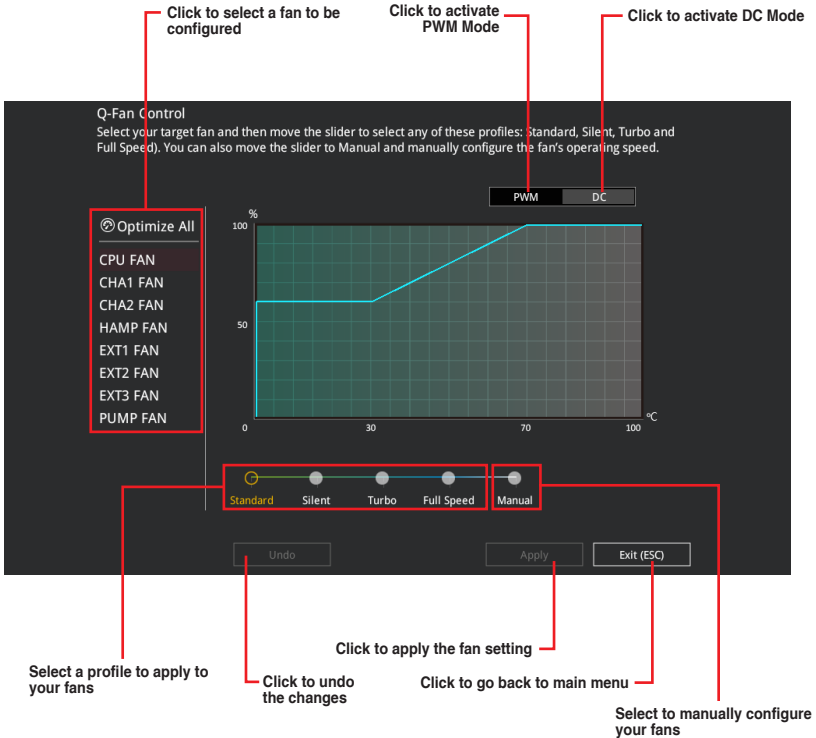

## Configuring fans manually

Select **Manual** from the list of profiles to manually configure your fans' operating speed.

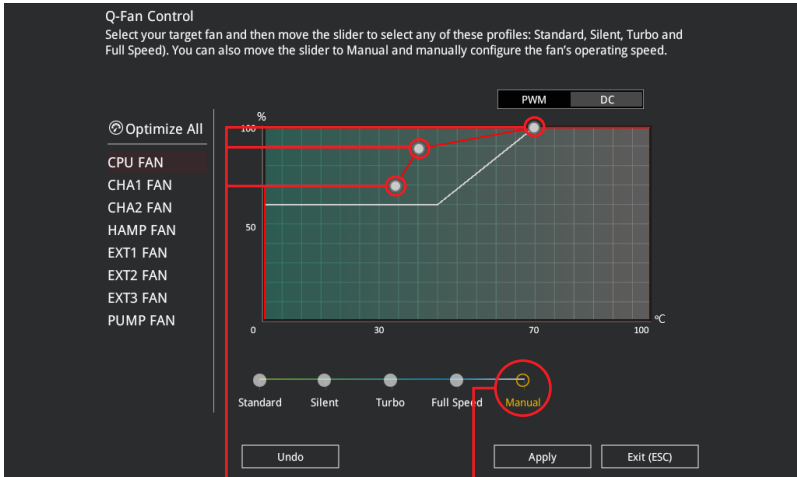

Speed points

Select to manually  
configure your fans

To configure your fans:

1. Select the fan that you want to configure and to view its current status.
2. Click and drag the speed points to adjust the fans' operating speed.
3. Click **Apply** to save the changes then click **Exit (ESC)**.



### 3.2.4 EZ Tuning Wizard

EZ Tuning Wizard allows you to easily overclock your CPU and DRAM, computer usage, and CPU fan to their best settings. You can also set RAID in your system using this feature.

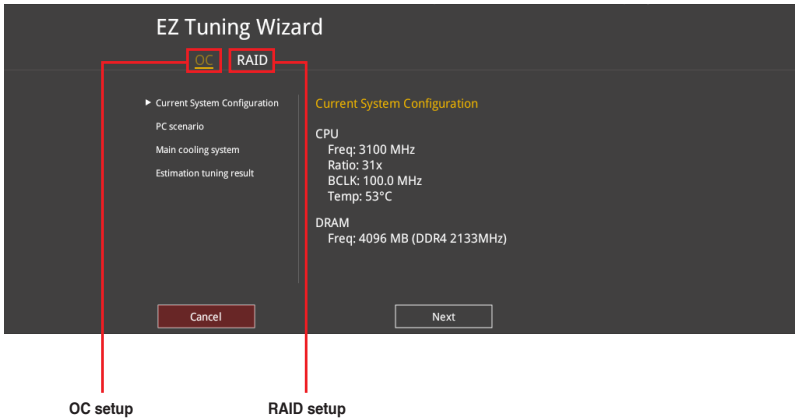

#### OC Tuning

To start OC Tuning:

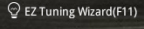
1. Press <F11> on your keyboard or click  from the BIOS screen to open EZ Tuning Wizard screen, then click **Next**.
2. Click **OC** then click **Next**.
3. Select a PC scenario **Daily Computing** or **Gaming/Media Editing**, then click **Next**.



4. Select a Main Cooling system **Box cooler**, **Tower cooler**, **Water cooler**, or **I'm not sure**, then click **Next**.



5. After selecting the Main Cooling system, click **Next** then click **Yes** to start the OC Tuning.

## Creating RAID

To create RAID:

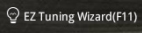
1. Press <F11> on your keyboard or click  from the BIOS screen to open EZ Tuning Wizard screen.
2. Click **RAID** then click **Next**.



- Ensure that your HDDs have no existing RAID volumes.
- Ensure to connect your HDDs to Intel® SATA connectors.

3. Check the available storage disk drives, then click **Next**.

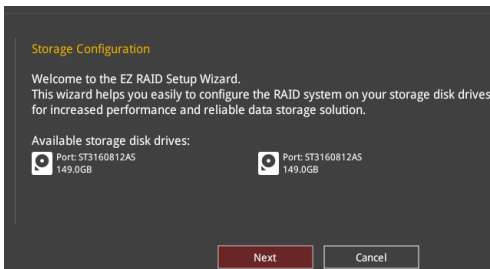

4. Select the type of storage for your RAID, **Easy Backup** or **Super Speed**, then click **Next**.

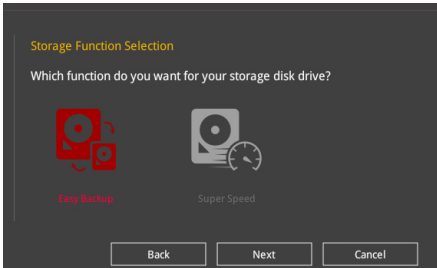

- a. For Easy Backup, click **Next** then select from **Easy Backup (RAID1)** or **Easy Backup (RAID10)**.

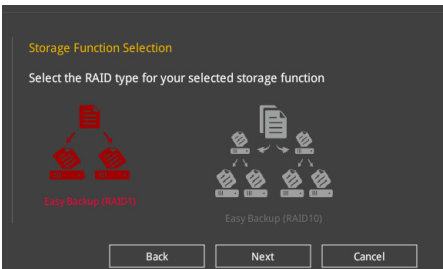

---

You can only select Easy Backup (RAID10) if you connect four (4) HDDs.

---

- b. For Super Speed, click **Next** then select from **Super Speed (RAID 0)** or **Super Speed (RAID 5)**.

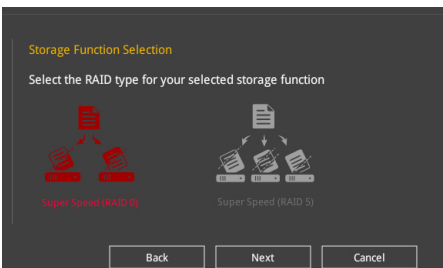

5. After selecting the type of RAID, click **Next** then click **Yes** to continue the RAID setup.
6. After the RAID setup is done, click **Yes** to exit the setup then click **OK** to reset your system.

### 3.3 My Favorites

MyFavorites is your personal space where you can easily save and access your favorite BIOS items.

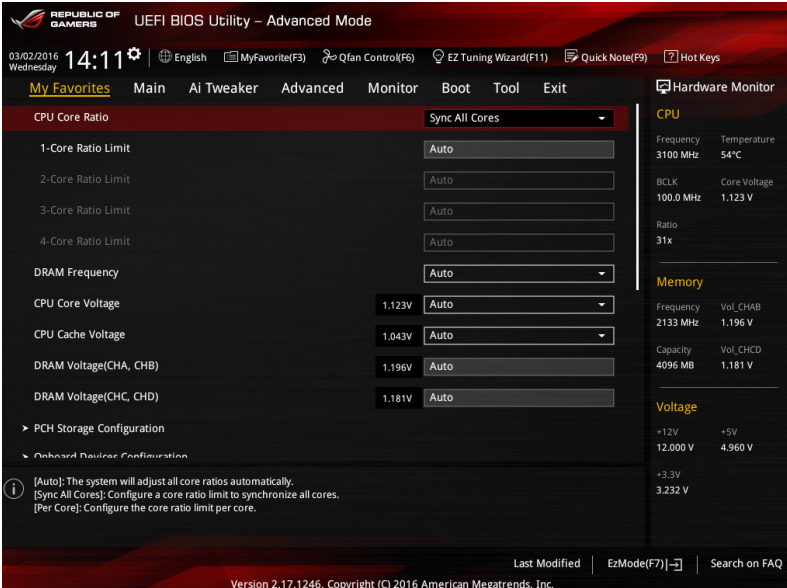



My Favorites comes with several performance, power saving, and fast boot related items by default. You can personalize this screen by adding or removing items.

## Adding items to My Favorites

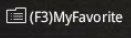
To add BIOS items:

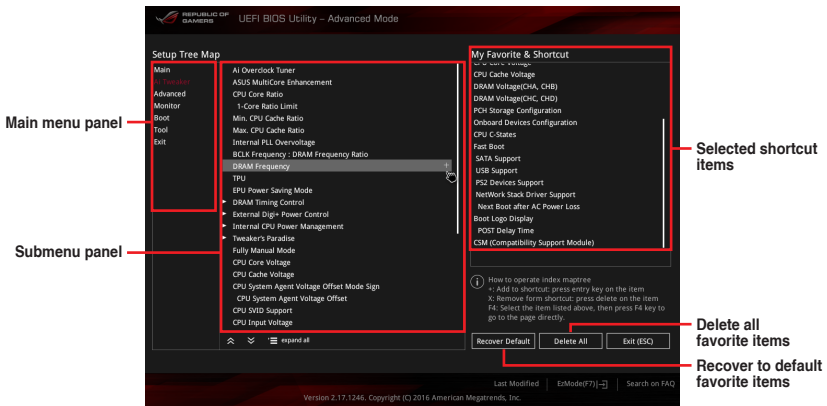
1. Press <F3> on your keyboard or click  from the BIOS screen to open Setup Tree Map screen.
2. On the Setup Tree Map screen, select the BIOS items that you want to save in My Favorites screen.



3. Select an item from main menu panel, then click the submenu that you want to save as favorite from the submenu panel and tap or click  or press <Enter> on your keyboard.



You cannot add the following items to My Favorite items:

- Items with submenu options
- User-managed items such as language and boot order
- Configuration items such as Memory SPD Information, system time and date

4. Click **Exit (ESC)** or press <Esc> key to close Setup Tree Map screen.
5. Go to My Favorites menu to view the saved BIOS items.

### 3.4 Main menu

The Main menu screen appears when you enter the Advanced Mode of the BIOS Setup program. The Main menu provides you an overview of the basic system information, and allows you to set the system date, time, language, and security settings.

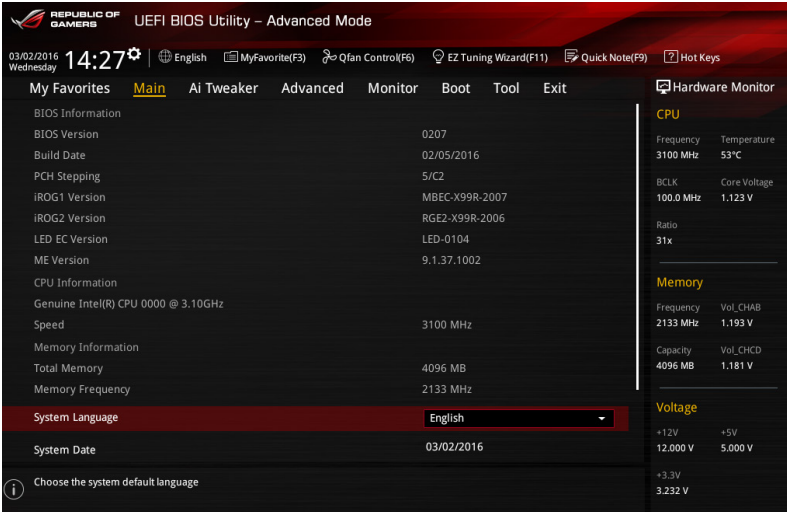

### Security

The Security menu items allow you to change the system security settings.

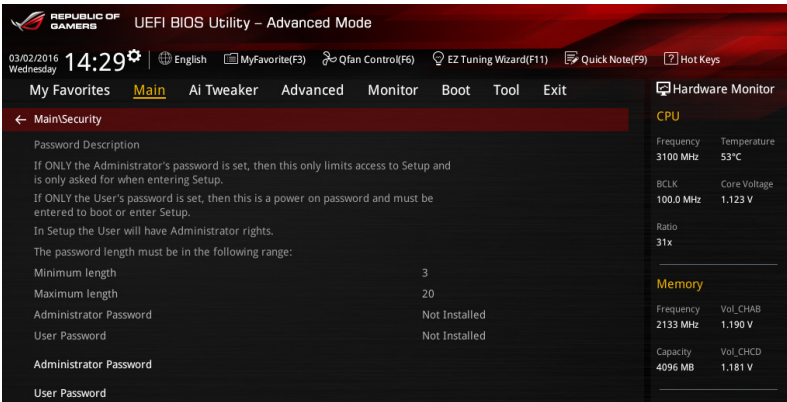

- If you have forgotten your BIOS password, erase the CMOS Real Time Clock (RTC) RAM to clear the BIOS password. See section 1.1.6 Onboard buttons and switches for information on how to erase the RTC RAM via the Clear CMOS button.
- The Administrator or User Password items on top of the screen show the default **[Not Installed]**. After you set a password, these items show **[Installed]**.

## 3.5 Ai Tweaker menu

The Ai Tweaker menu items allow you to configure overclocking-related items.



Be cautious when changing the settings of the Ai Tweaker menu items. Incorrect field values can cause the system to malfunction.



The configuration options for this section vary depending on the CPU and DIMM model you installed on the motherboard.

Scroll down to display other BIOS items.

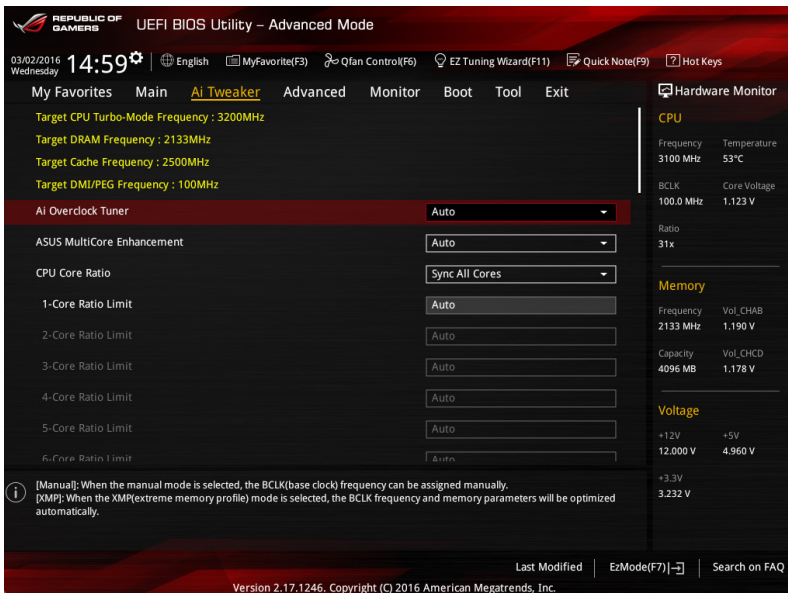

### Ai Overclock Tuner [Auto]

This item allows you to select the CPU overclocking options to achieve the desired CPU internal frequency. Select any of these preset overclocking configuration options:

- [Auto] Loads the optimal settings for the system.
- [Manual] Automatically optimizes the CPU ratio and BCLK frequency.



The following item appears only when you set the Ai Overclocking Tuner to [Manual].

### CPU Strap [Auto]

This item allows you to select a strap value close to the target BCLK frequency for an extreme overclocking.

Configuration options: [Auto] [100MHz] [125MHz] [167MHz] [250MHz]



---

The following item appears only when you set the CPU Strap to [100MHz], [125MHz], [167MHz], or [250MHz].

---

#### **Source Clock Tuner [Auto]**

This item allows you to select the source clock based on the assigned CPU strap for a better overlocking capability.

Configuration options: [Auto] [8Ohm db] [7Ohm db] [6Ohm db]  
[5Ohm db] [4Ohm db] [3Ohm db] [2Ohm db]

#### **PLL Selection [Auto]**

This item is set to LC PLL by default for better stability. Select SB PLL when BCLK (base clock) frequency is far away from 100MHz. This may affect the functionality of other devices which need precise clock jitters.

Configuration options: [Auto] [LC PLL] [SB PLL]

#### **Filter PLL [Auto]**

Set this item to high BCLK (base clock) mode when using a very high BCLK to improve the overlocking capability.

Configuration options: [Auto] [Low BCLK mode] [High BCLK mode]

#### **BCLK Frequency [100.0]**

This item allows you to set the BCLK (base clock) frequency to enhance the system performance. Use the <+> or <-> to adjust the value. The value ranges from 80.0MHz to 300.0MHz.



---

We recommend you to set the value based on the CPU specification as high BCLK frequencies may damage the CPU permanently.

---

#### **Initial BCLK Frequency [Auto]**

This item allows you to start overlocking the system from the initial BCLK (base clock) frequency to the assigned BCLK frequency. Use the <+> or <-> to adjust the value.

The value ranges depend on the value you set on BCLK frequency.

#### **ASUS MultiCore Enhancement [Auto]**

[Auto] This item allows you to apply ASUS optimized core ratio settings when overlocking.

[Disabled] This item allows you to apply the default core ratio settings.

#### **CPU Core Ratio [Sync All Cores]**

This item allows you to set the CPU core ratio limit per core or synchronize automatically to all cores.

Configuration options: [Auto] [Sync All Cores] [Per Core]



### **BCLK Frequency: DRAM Frequency Ratio [Auto]**

This item allows you to set the BCLK frequency to DRAM frequency ratio.

- [Auto] The BCLK frequency to DRAM frequency ratio will be set to the optimized setting.
- [100:100] The BCLK frequency to DRAM frequency ratio will be set to 100:100.
- [100:133] The BCLK frequency to DRAM frequency ratio will be set to 100:133.

### **DRAM Frequency [Auto]**

This item allows you to select the DRAM operating frequency. The configurable options vary with the BCLK (base clock) frequency setting. Select the auto mode to apply the optimized setting.

Configuration options: [Auto] [DDR4-800MHz] – [DDR4-4000MHz]

### **TPU [Keep Current Settings]**

This item allows you to automatically overclock the frequency and voltage of CPU and DRAM respectively to enhance the system performance.

- [Keep Current Settings] Keep the current settings without changing anything.
- [TPU I] Applies air cooling overclocking conditions.
- [TPU II] Applies water cooling overclocking conditions.

### **EPU Power Saving Mode [Disabled]**

The ASUS EPU (Energy Processing Unit) sets the CPU in its minimum power consumption settings. Enable this item to set lower CPU Input Voltage and Vcore voltages and achieve the best energy saving condition.

Configuration options: [Disabled] [Enabled]

### **DRAM Timing Control**

The subitems in this menu allow you to set the DRAM timing control features. Use the <+> or <-> keys to adjust the value. To restore the default setting, type [auto] using the keyboard and press the <Enter> key.



---

Changing the values in this menu may cause the system to become unstable! If this happens, revert to the default settings.

---

## External Digi+ Power Control

### CPU Input Boot Voltage [Auto]

This item allows you to set a higher CPU input boot voltage for better overclocking capability. Use the <+> or <-> to adjust the value. The values range from 0.80V to 2.7V with an interval of 0.01V.

### CPU Load-line Calibration [Auto]

The load-line is defined by the Intel VRM specification and affects the CPU power voltage. The CPU working voltage will decrease proportionally depending on the CPU loading. Higher levels of the load-line calibration can get a higher voltage and a better overclocking performance, but increase the CPU and VRM thermal production. Select from levels 1 to 9 to adjust the CPU power voltage from 0% to 125%.

Configuration options [Auto] [Level 1] - [Level 9]



---

The actual performance boost may vary depending on your CPU specification.

---



---

DO NOT remove the thermal module. The thermal conditions should be monitored.

---

## Internal CPU Power Management

The subitems in this menu allow you to set the CPU ratio and its features.

### Turbo Mode [Enabled]

This item enables the CPU cores to run faster than the base operating frequency when they are below the operating power, current and temperature specification.

Configuration options: [Disabled] [Enabled]

### Extreme Over-voltage [Disabled]

Disable this item to protect the CPU from damage by over-voltage or enable to choose a high voltage for overclocking.

Configuration options: [Disabled] [Enabled]



---

This item can only be enabled when the onboard CPU OverVoltage jumper is switched on. Refer to section 1.1.2 **Motherboard layout** for the location of the CPU Overvoltage jumper.

---

### CPU Core Voltage [Auto]

This item allows you to configure the amount of voltage fed to the CPU cores. Increase the voltage when configuring a high CPU core frequency.

Configuration options: [Auto] [Manual Mode] [Offset Mode] [Adaptive Mode]

### 3.6 Advanced menu

The Advanced menu items allow you to change the settings for the CPU and other system devices.



Be cautious when changing the settings of the Advanced menu items. Incorrect field values can cause the system to malfunction.

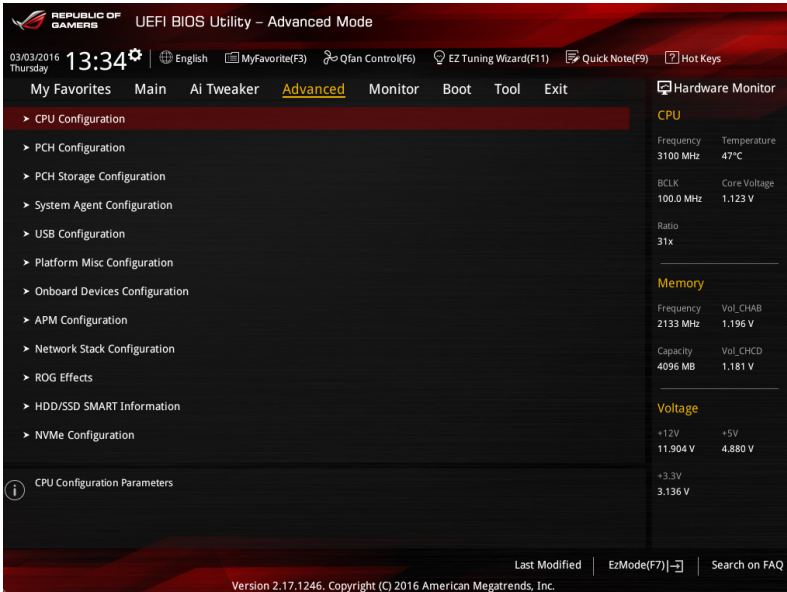

### 3.6.1 CPU Configuration

The items in this menu show the CPU-related information that the BIOS automatically detects.



The items in this menu may vary based on the CPU installed.



#### Hyper-Threading [ALL] [Enabled]

This item allows you to enable or disable the Hyper Threading for Logical Processor threads. Configuration options: [Disabled] [Enabled]

#### CPU Power Management Configuration

The items in this menu allow you to manage and configure the CPU's power.

## 3.6.2 PCH Configuration

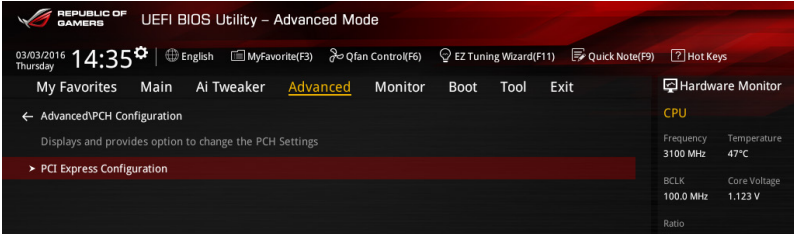

### PCI Express Configuration

This item allows you to configure the PCI Express slots.

#### PCIEX4\_1 Speed [Auto]

This item allows you to configure the speed for PCIe x4\_1 slot.  
Configuration options: [Auto] [Gen1] [Gen2]

#### PCIEX1\_2 Speed [Auto]

This item allows you to configure the speed for PCIe x1\_2 slot.  
Configuration options: [Auto] [Gen1] [Gen2]

### 3.6.3 PCH Storage Configuration

While entering Setup, the BIOS automatically detects the presence of SATA devices. The SATA Port items show **Not Installed** if no SATA device is installed to the corresponding SATA port.

Scroll down to display the other BIOS items.

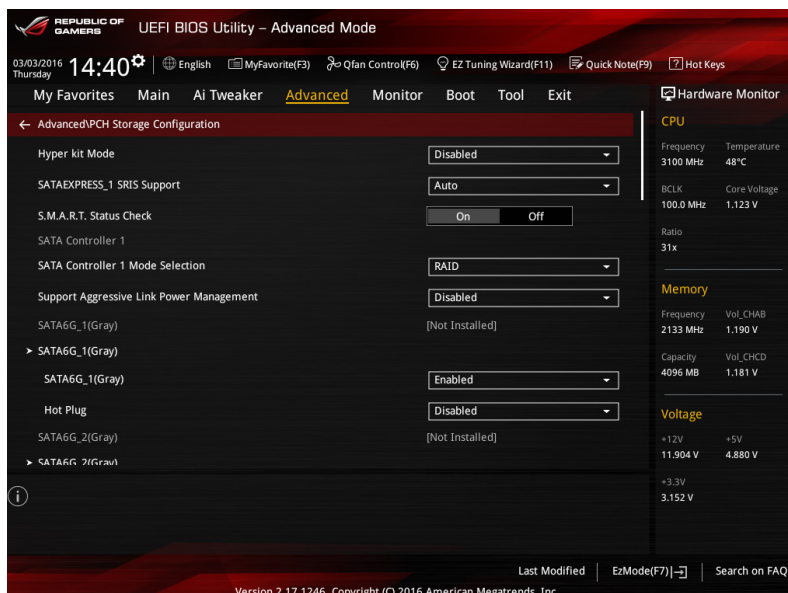

#### SATA Controller 1 Mode Selection [AHCI]

This item allows you to set the SATA configuration.

- [Disabled] Disable the SATA function.
- [IDE] Set to [IDE] to use SATA hard disks as Parallel ATA storage devices.
- [AHCI] The AHCI (Advanced Host Controller Interface) allows the onboard storage driver to enable advanced SATA features that increase storage performance on random workloads by internally optimizing the order of commands.
- [RAID] Create a RAID configuration from SATA hard disk drives.



The following item appears only when you set the SATA Controller 1 Mode Selection to [IDE].

#### SATA6G\_1-6(Gray)

These items display all connected devices to SATA6G ports. If some ports are not used, these items show **[Not Installed]**.

## SATA6G\_1(Gray) - SATA6G\_6(Gray)

### SATA6G\_1(Gray) - SATA6G\_6(Gray) [Enabled]

This item allows you to enable or disable the selected SATA port.

Configuration options: [Disabled] [Enabled]

### Hot Plug [Disabled]

This item allows you to designate selected SATA port as Hot Pluggable.

Configuration options: [Disabled] [Enabled]

## SATA Controller 2 Mode Selection [AHCI]

This item allows you to set the SATA configuration.

[Disabled]	Disable the SATA function.
[IDE]	Set to [IDE] to use SATA hard disks as Parallel ATA storage devices.
[AHCI]	The AHCI (Advanced Host Controller Interface) allows the onboard storage driver to enable advanced SATA features that increases storage performance on random workloads by internally optimizing the order of commands.



---

Due to Intel® chipset specification, the SATA ports from controller 2 do not support IRST including RAID configuration.

---



---

The following item appears only when you set the SATA Controller 2 Mode Selection to [IDE].

---

## SATA6G\_7-10(Black)

These items display all connected devices to SATA6G ports. If some ports are not used, these items show [Not Installed].

## Support Aggressive Link Power Management [Disabled]

This item allows you to enable or disable SALP.

Configuration options: [Disabled] [Enabled]

## Hot Plug [Disabled] (SATA6G\_1-6(Gray) / SATA6G\_7-10(Black))

This item allows you to designate selected SATA port as Hot Pluggable.

Configuration options: [Disabled] [Enabled]

### 3.6.4 System Agent Configuration

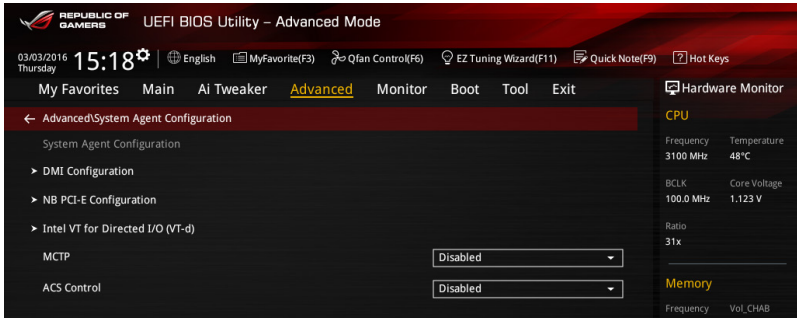

#### NB PCI-E Configuration

The items in this menu allow you to select the operating speed of the PCIEX16\_1 slots.

### 3.6.5 USB Configuration

The items in this menu allow you to change the USB-related features.

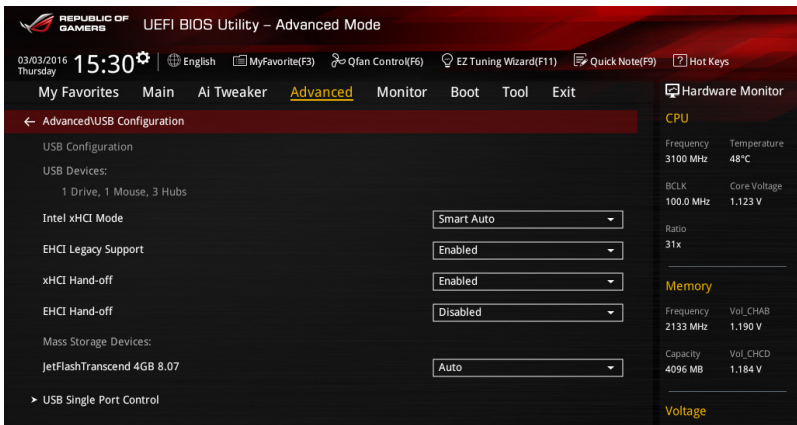

The **Mass Storage Devices** item shows the auto-detected values. If no USB device is detected, the item shows **None**.



## 3.6.6 Platform Misc Configuration

The items in this menu allow you to configure the platform-related features.

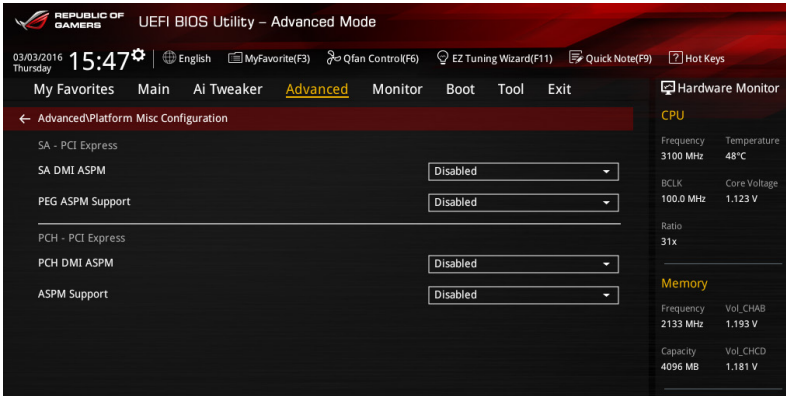

## 3.6.7 Onboard Devices Configuration

Scroll down to view the other BIOS items.

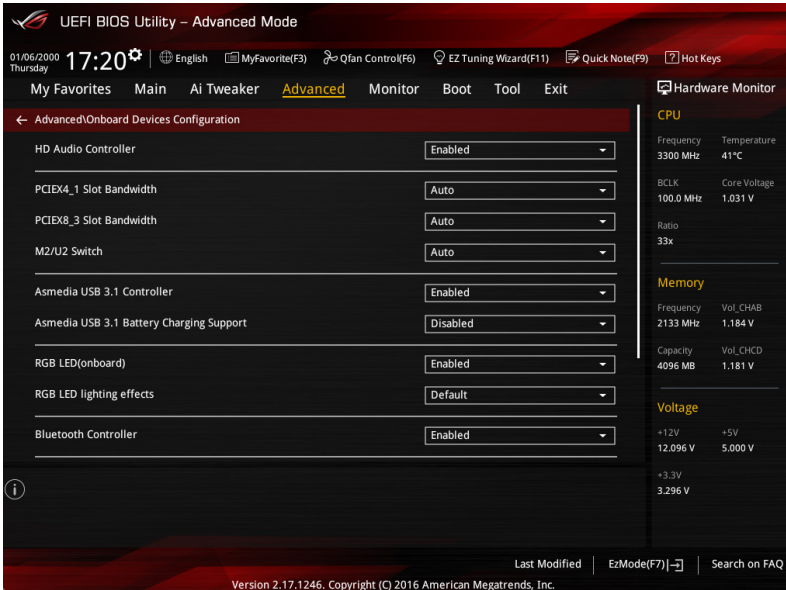

### **HD Audio Controller [Enabled]**

This item allows you to use the Azalia High Definition Audio Controller.

Configuration options: [Disabled] [Enabled]

### **PCIEX4\_1 Slot Bandwidth [Auto]**

[Auto] Runs at AUTO mode with USB3.1\_EC1, USB3.1\_EA2 enabled and PCIEX1\_2 slot enabled.

[X1 Mode] Runs at x1 mode with USB3.1\_EC1\_EA2 port and PCIEX1\_2 slot enabled.

[X4 Mode] Runs at x4 mode for a high performance support with USB3.1\_EC1\_EA2 ports and PCIEX1\_2 slot disabled.

### **PCIEX8\_3 Slot Bandwidth [Auto]**

[Auto] When a PCIe device higher than x4 interface is installed on the PCIEX8\_3 slot, PCIEX16/X8\_1 and PCIEX8\_3 slots will automatically run at x8 mode.

[X8 Mode] PCIEX16/X8\_1 and PCIEX8\_3 slots run at x8 mode. Supports x1/x2/x4/x8 devices.

### **M2/U2 Switch [Auto]**

[Auto] The bandwidth will be switched to U.2 by default. When a M.2 device is detected, the bandwidth will automatically be switched to M.2.

[M.2 Mode] The bandwidth will be switched to M.2 with U.2 disabled.

[U.2 Mode] The bandwidth will be switched to U.2 with M.2 disabled.

### **Asmedia USB 3.1 Controller [Enabled]**

This item allows you to enable or disable the Asmedia USB 3.1 controller of your system.

Configuration options: [Disabled] [Enabled]

### **Asmedia USB 3.1 Battery Charging Support [Disabled]**

This item allows you to enable or disable the Asmedia USB 3.1 Battery Charging support of your system.

Configuration options: [Disabled] [Enabled]

### **RGB LED(onboard) [Enabled]**

[Disabled] LEDs will not light up.

[Enabled] LEDs will always light up at the S0(Working), S3(Sleep), and S5(Soft off) states, but not at the S5 state when the ErP Ready is enabled.

## RGB LED lighting effects [Default]

This item allows you to set the RGB LED lighting effects.

Configuration options: [Default] [Auto] [Static] [Breathing] [Strobing] [Color Cycle]



---

The following item appears only when you set the RGB LED lighting effects to **[Static]**, **[Breathing]**, or **[Strobing]**.

---

## RGB LED lighting color

This item allows you to set the RGB LED lighting colors.

## Bluetooth Controller [Enabled]

This item allows you to enable or disable the Bluetooth Controller.

Configuration options: [Disabled] [Enabled]

## Wi-Fi Controller/PCIEx1\_1 [Enabled]

[Disabled]      Disable Wi-Fi Controller and enable PCIEx1\_1.

[Enabled]        Enable Wi-Fi Controller and disable PCIEx1\_1.

## Intel LAN Controller [Enabled]

This item allows you to enable or disable the GbE Controller.

Configuration options: [Disabled] [Enabled]



---

The following item appears only when you set the Intel LAN Controller to **[Enabled]**.

---

## Intel LAN PXE Option ROM [Off]

This item allows you to launch Intel PXE OPROM.

Configuration options: [On] [Off]

## Serial Port Configuration

The items in this menu allows you to set the parameters of the serial port.



---

The items in this menu functions only if a serial port connector is installed on the motherboard.

---

## Serial Port [On]

This item allows you to enable or disable the serial port.

Configuration options: [On] [Off]

## Change Settings [IO=3F8h; IRQ=4]

This item allows you to select an optimal setting for Super IO device.

Configuration options: [IO=3F8h; IRQ=4] [IO=2F8h; IRQ=3]  
[IO=3E8h; IRQ=4] [IO=2E8h; IRQ=3]

### 3.6.8 APM Configuration

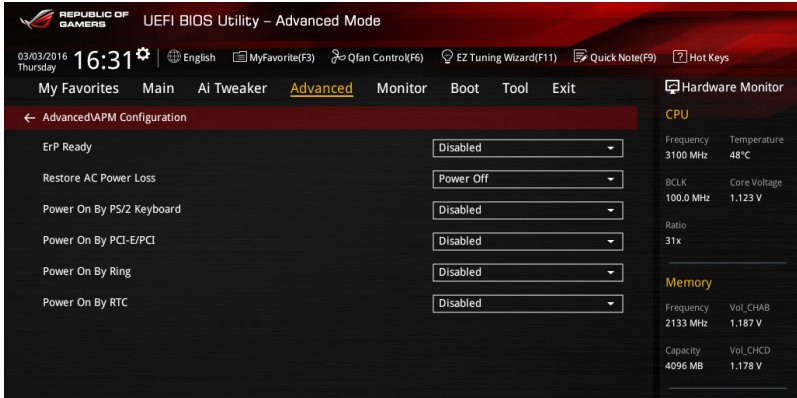

#### ErP Ready [Disabled]

This item allows you to switch off some power at S4/S5 to get the system ready for ErP requirement. When set to **[Enabled]**, all other PME options will be switched off.

Configuration options: [Disabled] [Enabled(S4+S5)] [Enabled(S5)]

### 3.6.9 Network Stack Configuration

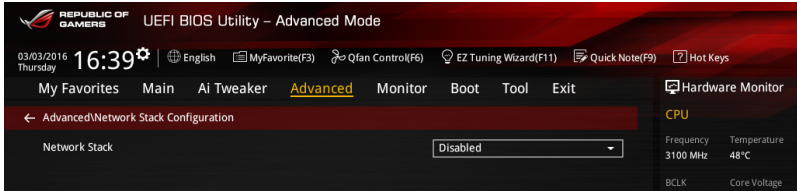

#### Network stack [Disabled]

This item allows you to enable or disable the UEFI Network Stack.

Configuration options: [Disabled] [Enabled]

### 3.6.10 HDD/SSD SMART Configuration

This menu displays the SMART information of the connected devices.

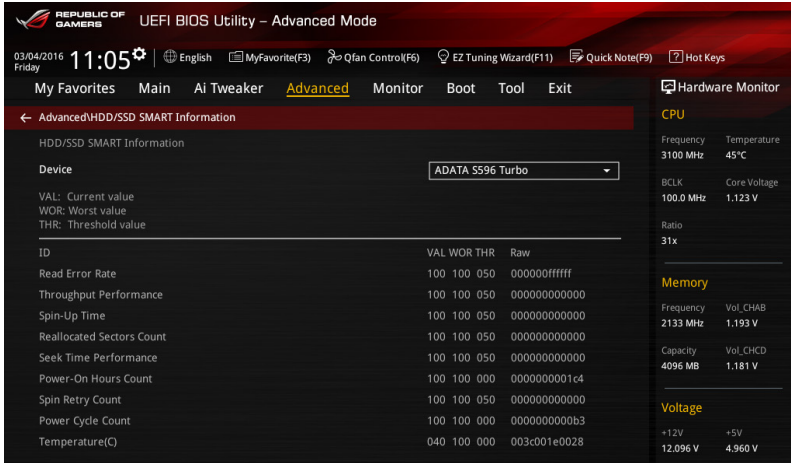

### 3.6.11 NVMe Configuration

This menu displays the NVMe controller and drive information of the connected devices.

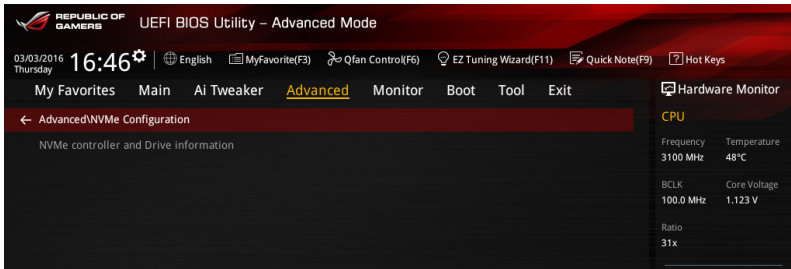

### 3.7 Monitor menu

The Monitor menu displays the system temperature/power status, and allows you to change the fan settings.

Scroll down to display the other BIOS items.



#### CPU Q-Fan Control [Auto]

[Auto] Detect the type of CPU fan installed and automatically switch the control modes.

[PWM Mode] Enable the CPU Q-Fan control feature in PWM mode for 4-pin CPU fan.

[DC Mode] Enable the CPU Q-Fan control feature in DC mode for 3-pin CPU fan.

[Disabled] Disable the Q-Fan control.

#### Chassis Fan 1/2 Q-Fan Control [DC Mode]

These items allow you to set the chassis fan Q-Fan control feature in DC mode, PWM Mode, or disable the chassis fan Q-Fan control.

Configuration options: [Disabled] [Auto] [DC Mode] [PWM Mode]

### **Water Pump Control [Disabled]**

This item allows you to set Water Pump Control.

Configuration options: [Disabled] [Auto] [DC Mode] [PWM Mode]

### **HAMP Fan Control [Auto]**

This item allows you to set HAMP Fan Control.

Configuration options: [Disabled] [Auto] [DC Mode] [PWM Mode]

### **HAMP Q-Fan Source [CPU]**

This item controls the assigned fan according to the selected temperature source.

Configuration options: [CPU] [MotherBoard] [PCIEX16/X8\_1 Slot] [PCIEX16\_2 Slot]  
[VRM] [PCH] [T\_Sensor1] [Ext\_Sensor1] [Ext\_Sensor2]  
[Ext\_Sensor3] [Multiple Sources]

### **HAMP Fan Speed Low Limit [300 RPM]**

This item allows you to select the lower speed limit for the HAMP fan.

Configuration options: [Ignore] [200 RPM] [300 RPM] [400 RPM] [500 RPM] [600 RPM]

### **HAMP Fan Profile [Standard]**

This item allows you to select the appropriate performance level of the HAMP fan.

Configuration options: [Standard] [Silent] [Turbo] [Manual]

### **Extension Fan 1/2/3 Q-Fan Control [DC Mode]**

These items allow you to set the extension fan Q-Fan control feature in DC Mode, PWM Mode, or disable the extension Q-Fan controls.

Configuration options: [Disabled] [DC Mode] [PWM Mode]

## 3.8 Boot menu

The Boot menu items allow you to change the system boot options.

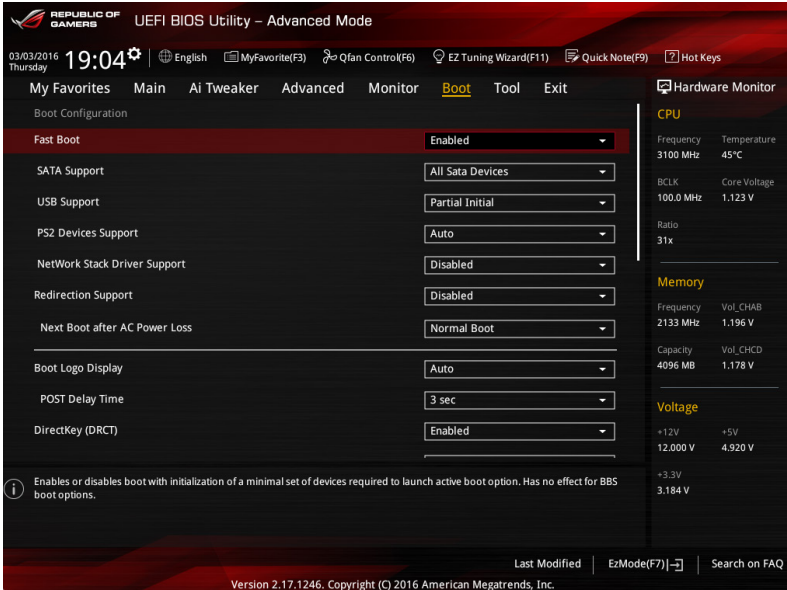

### Fast Boot [Enabled]

[Disabled] This item allows your system to go back to its normal boot speed.

[Enabled] This item allows your system to accelerate the boot speed.

### Redirection Support [Disabled]

If disabled, Redirection function will be disabled.

Configuration options: [Disabled] [Enabled]

### Boot Logo Display [Auto]

[Auto] Auto adjustment for Windows requirements.

[Full Screen] Maximize the boot logo size.

[Disabled] Hide the logo during POST.

### DirectKey (DRCT) [Enabled]

[Disabled] The system will only turn on or off when the reset button is pressed.

[Enabled] Allow the system to turn on and go to the BIOS Setup directly when the reset button is pressed. Connect the 2-pin connector of the chassis reset button cable to the onboard DRCT header to support this function.



## Setup Mode [EZ Mode]

- [Advanced Mode] This item allows you to go to Advanced Mode of the BIOS after POST.
- [EZ Mode] This item allows you to go to EZ Mode of the BIOS after POST.

## CSM (Compatibility Support Module)

This item allows you to configure the CSM (Compatibility Support Module) items to fully support the various graphics, bootable devices, and add-on devices for a better compatibility.

### Launch CSM [Enabled]

- [Auto] The system will automatically detect the states of bootable devices and the add-on devices for CSM support.
- [Enabled] For a better compatibility, enable the CSM to fully support the non-UEFI driver add-on devices or the Windows® UEFI mode.
- [Disabled] Disable the CSM to fully support the Windows secure update and secure boot.



---

The following items appear only when you set the Launch CSM to **[Enabled]**.

---

### Boot Device Control [UEFI and Legacy OPROM]

This item allows you to select the devices boot-up mode by the devices specification.

Configuration options: [UEFI and Legacy OPROM] [Legacy OPROM only] [UEFI only]

### Boot from Network Devices [Legacy only]

This item allows you to select the type of the onboard LAN controllers and installed LAN cards.

Configuration options: [Ignore] [Legacy only] [UEFI driver first]

### Boot from Storage Devices [Legacy only]

This item allows you to select the type of storage devices that will run first during the system boot.

Configuration options: [Ignore] [Legacy only] [UEFI driver first]

### Boot from PCI-E/PCI Expansion Devices [Legacy only]

This item allows you to select the type of PCI-E/PCI expansion devices that will run first during the system boot.

Configuration options: [Legacy only] [UEFI driver first]

## Secure Boot

This item allows you to configure the Windows® Secure Boot settings and manage its keys to protect the system from unauthorized access and malwares during POST.

### OS Type [Windows UEFI mode]

[Windows UEFI mode] Execute the Microsoft secure boot check. Only check this option when booting on Windows UEFI mode or other Microsoft secure boot compliant operating systems.

[Other OS] Select this option to get the optimized functions when booting on Windows non-UEFI mode and Microsoft secure boot non-compliant operating systems.

## Boot Option Priorities

These items specify the boot device priority sequence from the available devices. The number of device items that appears on the screen depends on the number of devices installed in the system.



- To access Windows® OS in Safe Mode, press <F8> after POST (Windows® 8 not supported).
- To select the boot device during system startup, press <F8> when ASUS Logo appears.

## Boot Override

These item displays the available devices. The number of device items that appear on the screen depends on the number of devices installed in the system. Click an item to start booting from the selected device.

## 3.9 Tool menu

The Tool menu items allow you to configure options for special functions. Select an item then press <Enter> to display the submenu.

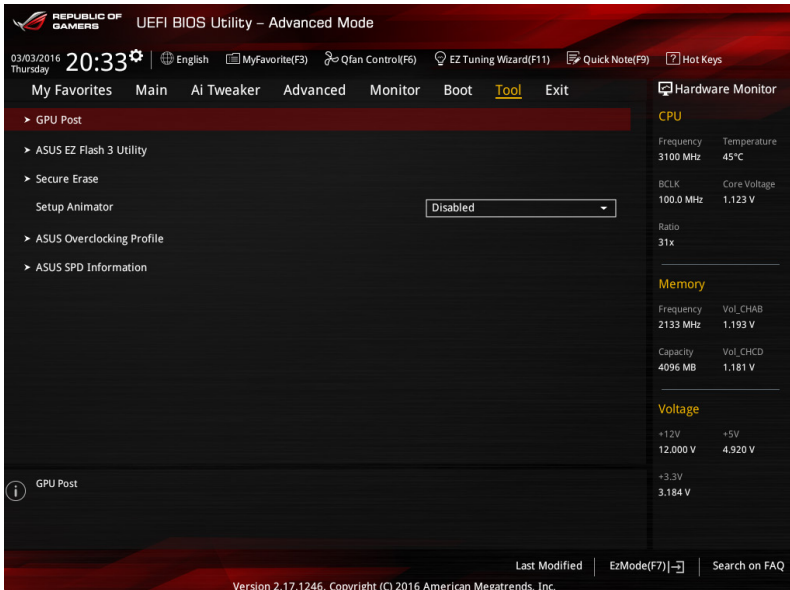

### GPU Post

This item shows the installed graphics cards in the motherboard. It also suggests the configuration of graphic cards in the motherboard for the best performance.

#### 3.9.1 ASUS EZ Flash 3 Utility

This item allows you to run ASUS EZ Flash 3. When you press <Enter>, a confirmation message appears. Use the left/right arrow key to select between [Yes] or [No], then press <Enter> to confirm your choice.



For more details, refer to section 3.11.2 ASUS EZ Flash 3.

### 3.9.2 Secure Erase

SSD speeds may lower over time as with any storage medium due to data processing. Secure Erase completely and safely cleans your SSD, restoring it to factory performance levels.



Secure Erase is only available in AHCI mode. Ensure to set the SATA mode to AHCI. Click **Advanced > PCH Storage Configuration > AHCI**.

To launch Secure Erase, click **Tool > Secure Erase** on the Advanced mode menu.



Check the ASUS support site for a full list of SSDs tested with Secure Erase. The ddrive may become unstable if you run Secure Erase on an incompatible SSD.



- The time to erase the contents of your SSD may take a while depending on its size. Do not turn off the system during the process.
- Secure Erase is only supported on Intel SATA port. For more information about Intel SATA ports, refer to section **1.1.2 Motherboard layout** of this manual.

Displays the available SSDs

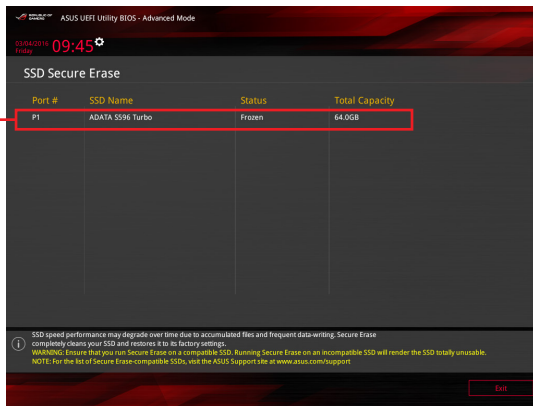

#### Status definition:

- **Frozen.** The frozen state is the result of a BIOS protective measure. The BIOS guards drives that do not have password protection by freezing them prior to booting. If the drive is frozen, a power off or hard reset of your PC must be performed to proceed with the Secure Erase.
- **Locked.** SSDs might be locked if the Secure Erase process is either incomplete or was stopped. This may be due to a third party software that uses a different password defined by ASUS. You have to unlock the SSD in the software before proceeding with Secure Erase.

## Setup Animator [Disabled]

This item allows you to enable or disable Setup Animator.

Configuration options: [Enabled] [Disabled]

### 3.9.3 ASUS Overclocking Profile

This item allows you to store or load multiple BIOS settings.

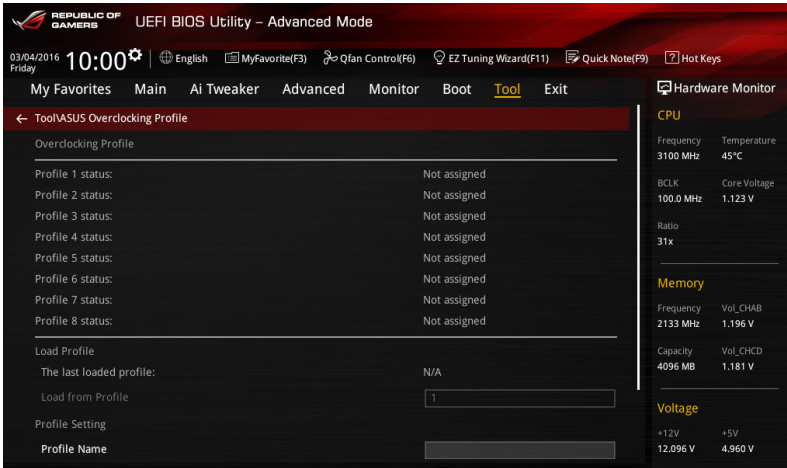

#### Load from Profile

This item allows you to load the previous BIOS settings saved in the BIOS Flash. Key in the profile number that saved your BIOS settings, press <Enter>, and then select **Yes**.



- DO NOT shut down or reset the system while updating the BIOS to prevent the system boot failure!
- We recommend that you update the BIOS file only coming from the same memory/CPU configuration and BIOS version.

#### Profile Name

This item allows you to key in a profile name.

#### Save to Profile

This item allows you to save the current BIOS settings to the BIOS Flash, and create a profile. Key in a profile number from one to eight, press <Enter>, and then select **Yes**.

#### Load/Save Profile from/to USB Drive

This item allows you to load or save profile from your USB drive, load and save profile to your USB drive.

### 3.9.4 ASUS SPD Information

This item allows you to view the DRAM SPD information.

REPUBLIC OF GAMERS UEFI BIOS Utility - Advanced Mode

03/04/2016 10:04 Friday English MyFavorite(F3) Qfan Control(F6) EZ Tuning Wizard(F11) Quick Note(F9) Hot Keys

My Favorites Main Ai Tweaker Advanced Monitor Boot Tool Exit

Hardware Monitor

← ToolASUS SPD Information

DIMM Slot Number: DIMM\_A1

Manufacturer: SK-Hynix  
Module Size: 4GB  
Maximum Bandwidth: 2133MHz  
Part Number: HMA45TUGMFR8N-TFND  
Serial Number: 10000007  
Product Week/Year: 09/2014  
SPD Ext.

JEDEC ID	JEDEC	JEDEC ID	JEDEC
Frequency (MHz)	2133	tWR	16
Voltage(V)	1.200	tRRD	4
tCL	15	tRFC	278
tRCD	15	tWTR	3
tRP	15	tRTP	8
tRAS	36	tFAW	23
tRC	50		

Information icon (i)

Last Modified | EZMode(F7) | Search on FAQ

Version 2.17.1246. Copyright (C) 2016 American Megatrends, Inc.

**CPU**

Frequency: 3100 MHz | Temperature: 44°C  
BCLK: 100.0 MHz | Core Voltage: 1.123 V  
Ratio: 31x

**Memory**

Frequency: 2133 MHz | Vol\_CHAB: 1.193 V  
Capacity: 4096 MB | Vol\_CHCD: 1.178 V

**Voltage**

+12V +5V  
12.096 V 4.960 V  
+3.3V  
3.232 V

## 3.10 Exit menu

The Exit menu items allow you to load the optimal default values for the BIOS items, and save or discard your changes to the BIOS items. You can access the EZ Mode from the Exit menu.

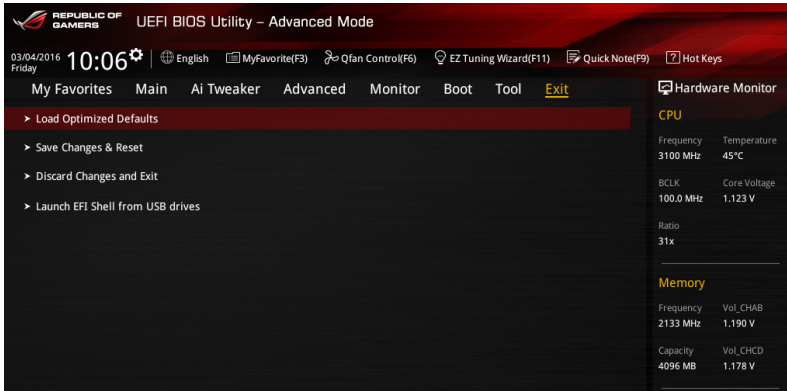

### Load Optimized Defaults

This option allows you to load the default values for each of the parameters on the Setup menus. When you select this option or if you press <F5>, a confirmation window appears. Select **OK** to load the default values.

### Save Changes & Reset

Once you are finished making your selections, choose this option from the Exit menu to ensure the values you selected are saved. When you select this option or if you press <F10>, a confirmation window appears. Select **OK** to save changes and exit.

### Discard Changes & Exit

This option allows you to exit the Setup program without saving your changes. When you select this option or if you press <Esc>, a confirmation window appears. Select **Yes** to discard changes and exit.

### Launch EFI Shell from USB drives

This option allows you to attempt to launch the EFI Shell application (shellx64.efi) from one of the available filesystem devices.

## 3.11 Updating BIOS

The ASUS website publishes the latest BIOS versions to provide enhancements on system stability, compatibility, and performance. However, BIOS updating is potentially risky. If there is no problem using the current version of BIOS, DO NOT manually update the BIOS. Inappropriate BIOS updating may result to system's failure to boot. Carefully follow the instructions in this chapter to update your BIOS when necessary.



---

Visit <http://www.asus.com> to download the latest BIOS file for this motherboard.

---

The following utilities allow you to manage and update the motherboard BIOS setup program.

1. EZ Update: Updates the BIOS in Windows® environment.
2. ASUS EZ Flash 3: Updates the BIOS using a USB flash drive.
3. ASUS CrashFree BIOS 3: Restores the BIOS using the motherboard support DVD or a USB flash drive when the BIOS file fails or gets corrupted.

### 3.11.1 EZ Update

The EZ Update is a utility that allows you to update the motherboard BIOS in Windows® environment.



- EZ Update requires an Internet connection either through a network or an ISP (Internet Service Provider).
  - This utility is available in the support DVD that comes with the motherboard package.
- 

### 3.11.2 ASUS EZ Flash 3

ASUS EZ Flash 3 allows you to download and update to the latest BIOS through the internet without having to use a bootable floppy disk or an OS-based utility.



---

Updating through the Internet varies per region and Internet conditions. Check your local Internet connection before updating through the Internet.

---

#### To update the BIOS by USB:

1. Enter the Advanced Mode of the BIOS setup program. Go to the Tool menu to select **ASUS EZ Flash 3 Utility** and press <Enter>.
2. Insert the USB flash disk that contains the latest BIOS file to the USB port, then select **via Storage Devices**.



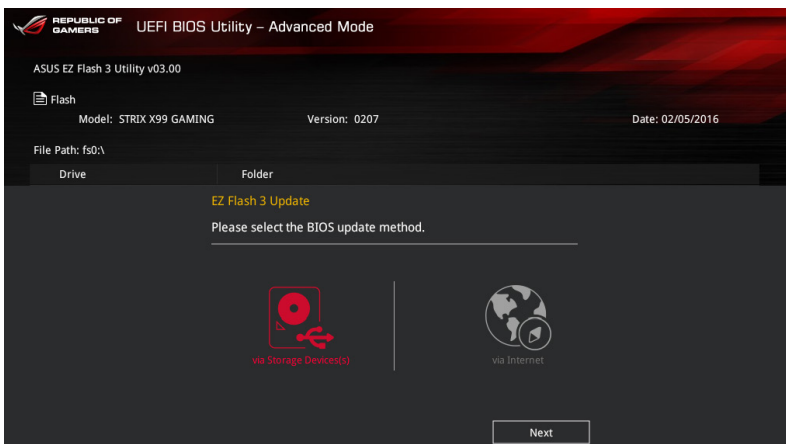

3. Press <Tab> to switch to the Drive field.
4. Press the Up/Down arrow keys to find the USB flash disk that contains the latest BIOS, and then press <Enter>.
5. Press <Tab> to switch to the Folder Info field.
6. Press the Up/Down arrow keys to find the BIOS file, and then press <Enter> to perform the BIOS update process. Reboot the system when the update process is done.

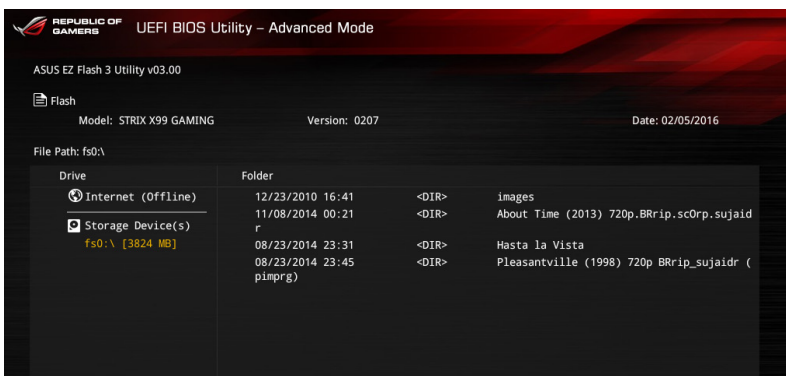



- This function can support devices such as a USB flash disk with FAT 32/16 format and single partition only.
- DO NOT shut down or reset the system while updating the BIOS to prevent system boot failure!



Ensure to load the BIOS default settings to ensure system compatibility and stability. Select the Load Optimized Defaults item under the Exit menu. See section 3.10 **Exit menu** for details.

## To update the BIOS by Internet:

1. Enter the Advanced Mode of the BIOS setup program. Go to the Tool menu to select **ASUS EZ Flash 3 Utility** and press <Enter>.
2. Select **via Internet**.

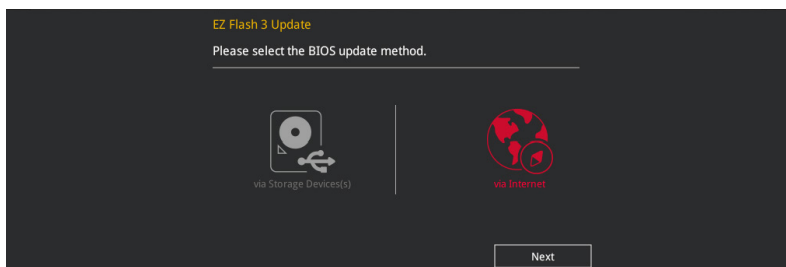

3. Press the Left/Right arrow keys to select an Internet connection method, and then press <Enter>

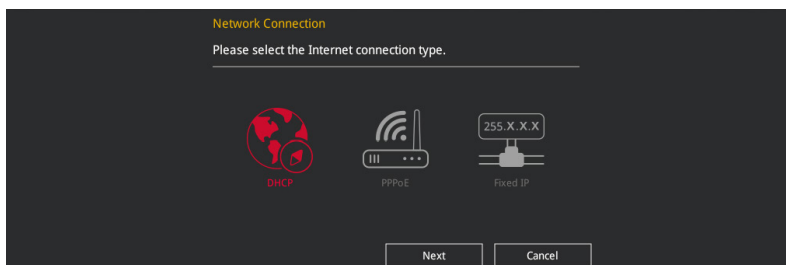

4. Follow the onscreen instructions to complete the update.
5. Reboot the system when the update process is done.



Ensure to load the BIOS default settings to ensure system compatibility and stability. Select the Load Optimized Defaults item under the Exit menu. See section 3.10 **Exit menu** for details.

### 3.11.3 ASUS CrashFree BIOS 3

The ASUS CrashFree BIOS 3 utility is an auto recovery tool that allows you to restore the BIOS file when it fails or gets corrupted during the updating process. You can restore a corrupted BIOS file using the motherboard support DVD or a USB flash drive that contains the BIOS file.



---

The BIOS file in the motherboard support DVD may be older than the BIOS file published on the ASUS official website. If you want to use the newer BIOS file, download the file at <https://www.asus.com/support> and save it to a USB flash drive.

---

#### Recovering the BIOS

To recover the BIOS:

1. Turn on the system.
2. Insert the motherboard support DVD to the optical drive, or the USB flash drive containing the BIOS file to the USB port.
3. The utility automatically checks the devices for the BIOS file. When found, the utility reads the BIOS file and enters ASUS EZ Flash 3 automatically.
4. The system requires you to enter BIOS Setup to recover the BIOS setting. To ensure system compatibility and stability, we recommend that you press <F5> to load default BIOS values.



---

**DO NOT** shut down or reset the system while updating the BIOS! Doing so can cause system boot failure!

---



# RAID Support

# 4

## 4.1 RAID configurations

The motherboard supports Intel® Rapid Storage Technology with RAID 0, RAID 1, RAID 10, and RAID 5 solution.



If you want to install a Windows® operating system to a hard disk drive included in a RAID set, you have to create a RAID driver disk and load the RAID driver during OS installation. Refer to section **4.2 Creating a RAID driver disk** for details.

### 4.1.1 RAID definitions

**RAID 0 (Data striping)** optimizes two identical hard disk drives to read and write data in parallel, interleaved stacks. Two hard disks perform the same work as a single drive but at a sustained data transfer rate, double that of a single disk alone, thus improving data access and storage. Use of two new identical hard disk drives is required for this setup.

**RAID 1 (Data mirroring)** copies and maintains an identical image of data from one drive to a second drive. If one drive fails, the disk array management software directs all applications to the surviving drive as it contains a complete copy of the data in the other drive. This RAID configuration provides data protection and increases fault tolerance to the entire system. Use two new drives or use an existing drive and a new drive for this setup. The new drive must be of the same size or larger than the existing drive.

**RAID 5** strips both data and parity information across three or more hard disk drives. Among the advantages of RAID 5 configuration include better HDD performance, fault tolerance, and higher storage capacity. The RAID 5 configuration is best suited for transaction processing, relational database applications, enterprise resource planning, and other business systems. Use a minimum of three identical hard disk drives for this setup.

**RAID 10** is data striping and data mirroring combined without parity (redundancy data) having to be calculated and written. With the RAID 10 configuration you get all the benefits of both RAID 0 and RAID 1 configurations. Use four new hard disk drives or use an existing drive and three new drives for this setup.

## 4.1.2 Installing Serial ATA hard disks

The motherboard supports Serial ATA hard disk drives. For optimal performance, install identical drives of the same model and capacity when creating a disk array.

To install the SATA hard disks for a RAID configuration:

1. Install the SATA hard disks into the drive bays.
2. Connect the SATA signal cables.
3. Connect a SATA power cable to the power connector on each drive.

## 4.1.3 Intel® Rapid Storage Technology in UEFI BIOS

To enter the Intel® Rapid Storage Technology in UEFI BIOS:

1. Enter the BIOS Setup during POST.
2. Go to the **Advanced** menu > **PCH Storage Configuration**, then press <Enter>.
3. Set the SATA Controller Mode Selection item to **[RAID Mode]**.
4. Go to the **Boot** menu > **CSM (Compatibility Support Module)** > **Launch CSM**, then set the item to **[Disabled]**.
5. Save your changes and exit the BIOS Setup, then enter the BIOS Setup again.
6. Go to the **Advanced** menu > **Intel(R) Rapid Storage Technology**, then press <Enter> to display the Intel® Rapid Storage Technology menu.



Refer to Chapter 3 for details on entering and navigating through the BIOS Setup.



Due to chipset limitation, when SATA ports are set to RAID mode, all SATA ports run at RAID mode together.

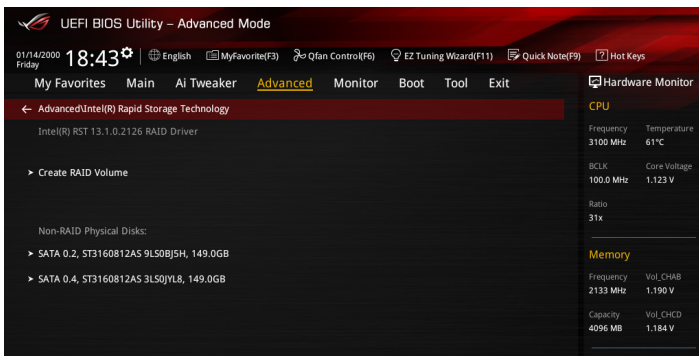

## Creating a RAID set

To create a RAID set:

1. From the Intel(R) Rapid Storage Technology menu, select **Create RAID Volume** and press <Enter>. The following screen appears:

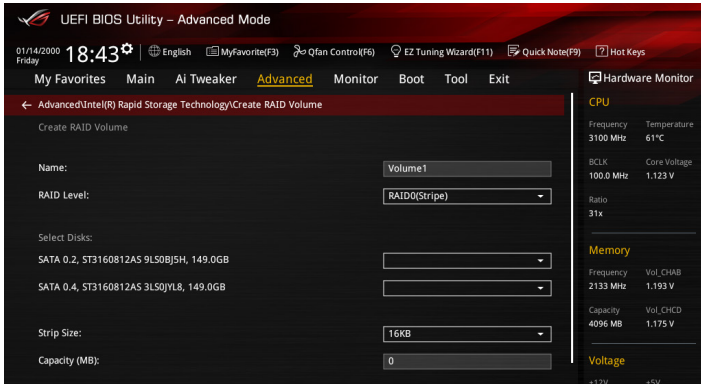

2. When the Name item is selected, enter a name for the RAID set and press <Enter>.
3. When the RAID Level item is selected, press <Enter> to select the RAID level to create, and then press <Enter>.
4. Under Select Disks, press <Enter> and select **X** for the disks you want to include in the RAID set.

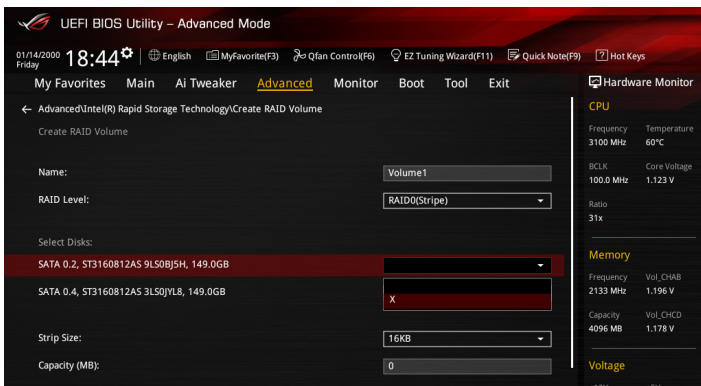

5. When the Strip Size item is selected, press <Enter> to select strip size for the RAID array (for RAID 0, 10 and 5 only), and then press <Enter>. The available strip size values range from 4 KB to 128 KB. The following are typical values:
  - RAID 0: 128 KB
  - RAID 10: 64 KB
  - RAID 5: 64 KB



We recommend a lower strip size for server systems, and a higher strip size for multimedia computer systems used mainly for audio and video editing.

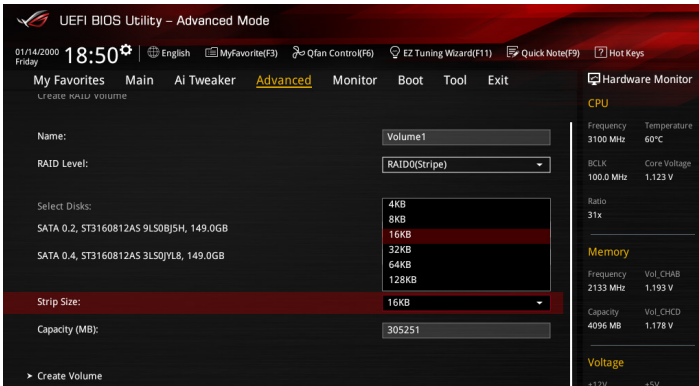

6. When the **Capacity (MB)** item is selected, enter the RAID volume capacity that you want and press <Enter>. The default value indicates the maximum allowed capacity.
7. When the **Create Volume** item is selected, press <Enter> to create the RAID volume and return to the Intel(R) Rapid Storage Technology menu.

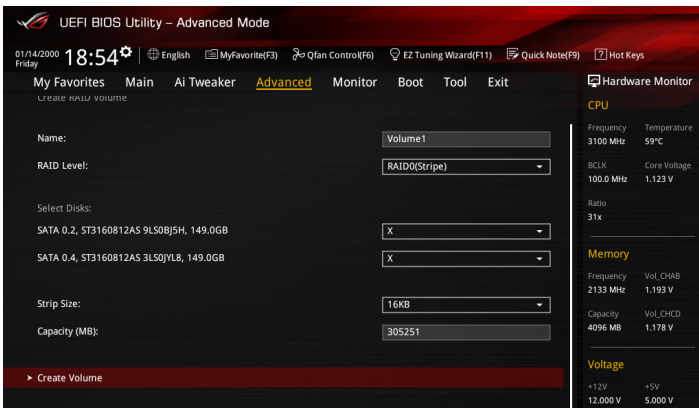



## Deleting a RAID set



Be cautious when deleting a RAID set. You will lose all data on the hard disk drives when you delete a RAID set.

To delete a RAID set:

1. From the Intel(R) Rapid Storage Technology menu, select the RAID volume you want to delete and press <Enter>. The following screen appears:

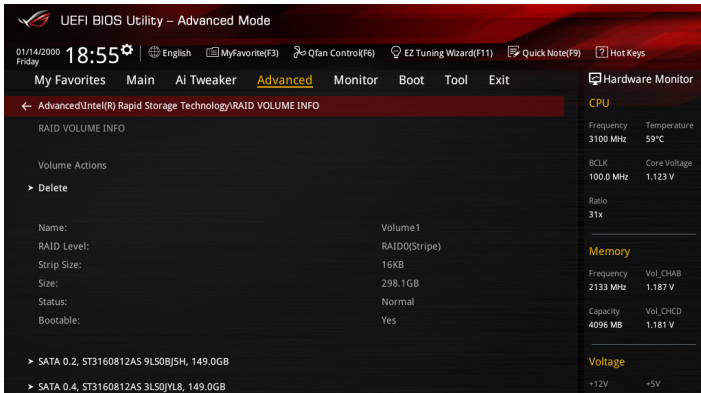

2. When the **Delete** item is selected, press <Enter>, then select **Yes** to delete the RAID volume and return to the Intel(R) Rapid Storage Technology menu, or select **No** to cancel.

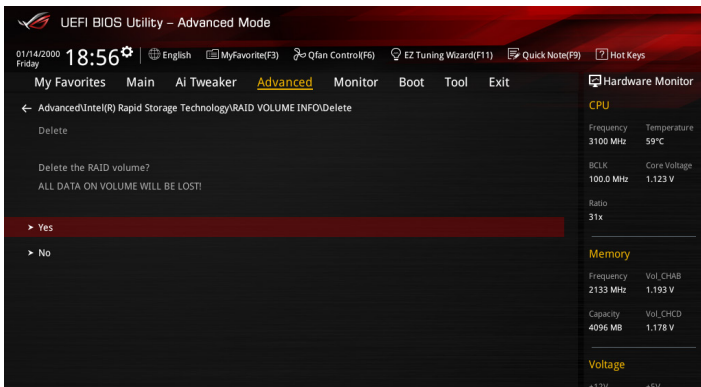

## 4.1.4 Intel® Rapid Storage Technology Option ROM utility

To enter the Intel® Rapid Storage Technology Option ROM utility:

1. Turn on the system.
2. During POST, press <Ctrl> + <I> to display the utility main menu.

```
Intel(R) Rapid Storage Technology - Option - v10.5.1.1070
Copyright(C) 2003-14 Intel Corporation. All Rights Reserved.

[ MAIN MENU ]

1. Create RAID Volume      4. Recovery Volume Options
2. Delete RAID Volume     5. Acceleration Options
3. Reset Disks to Non-RAID 6. Exit

[ DISK/VOLUME INFORMATION ]

RAID Volumes:
None defined.

Physical Devices:
Port  Device Model  Serial #      Size   Type/Status(Vol ID)
0      ST3160812AS      9LS0HJA4     149.0GB Non-RAID Disk
1      ST3160812AS      9LS0F4HL     149.0GB Non-RAID Disk
2      ST3160812AS      3LS0JYL8     149.0GB Non-RAID Disk
3      ST3160812AS      9LS0BJ5H     149.0GB Non-RAID Disk

[↑↓]-Select      [ESC]-Exit      [ENTER]-Select Menu
```

The navigation keys at the bottom of the screen allow you to move through the menus and select the menu options.



The RAID BIOS setup screens shown in this section are for reference only and may not exactly match the items on your screen.



The utility supports maximum four hard disk drives for RAID configuration.

## Creating a RAID set

To create a RAID set:

1. From the utility main menu, select **1. Create RAID Volume** and press <Enter>. The following screen appears:

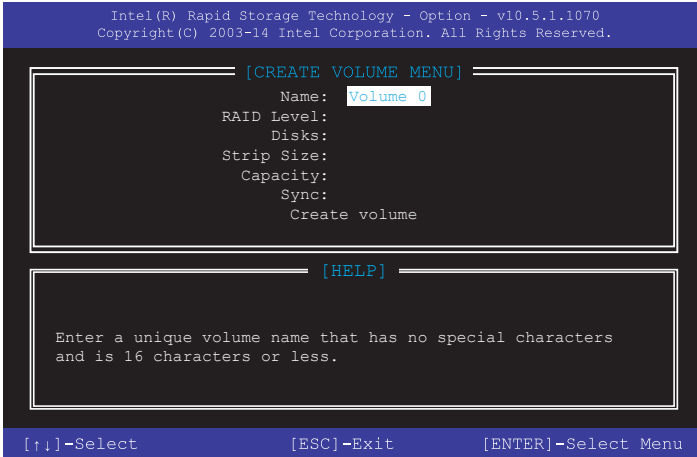

2. Enter a name for the RAID set and press <Enter>.
3. When the RAID Level item is selected, press the up/down arrow key to select a RAID level to create, and then press <Enter>.
4. When the Disks item is selected, press <Enter> to select the hard disk drives you want to include in the RAID set. The SELECT DISKS screen appears:

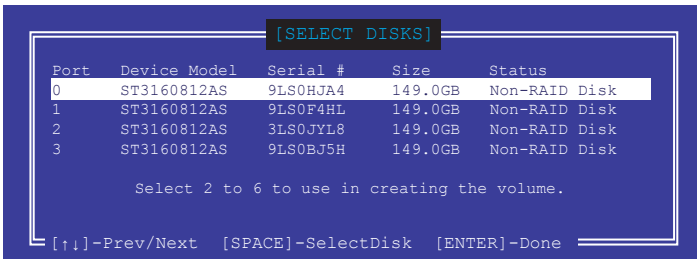

5. Use the up/down arrow key to select a drive, and then press <Space> to select. A small triangle marks the selected drive. Press <Enter> after completing your selection.
6. Use the up/down arrow key to select the strip size for the RAID array (for RAID 0, 10 and 5 only), and then press <Enter>. The available strip size values range from 4 KB to 128 KB. The following are typical values:
  - RAID 0: 128 KB
  - RAID 10: 64 KB
  - RAID 5: 64 KB



---

We recommend a lower strip size for server systems, and a higher strip size for multimedia computer systems used mainly for audio and video editing.

---

7. When the **Capacity** item is selected, enter the RAID volume capacity that you want and press <Enter>. The default value indicates the maximum allowed capacity.
8. When the **Create Volume** item is selected, press <Enter>. The following warning message appears:

WARNING: ALL DATA ON SELECTED DISKS WILL BE LOST.  
Are you sure you want to create this volume? (Y/N)

9. Press <Y> to create the RAID volume and return to the main menu, or <N> to go back to the CREATE VOLUME menu.

## Deleting a RAID set



Be cautious when deleting a RAID set. You will lose all data on the hard disk drives when you delete a RAID set.

To delete a RAID set:

1. From the utility main menu, select **2. Delete RAID Volume** and press <Enter>. The following screen appears:

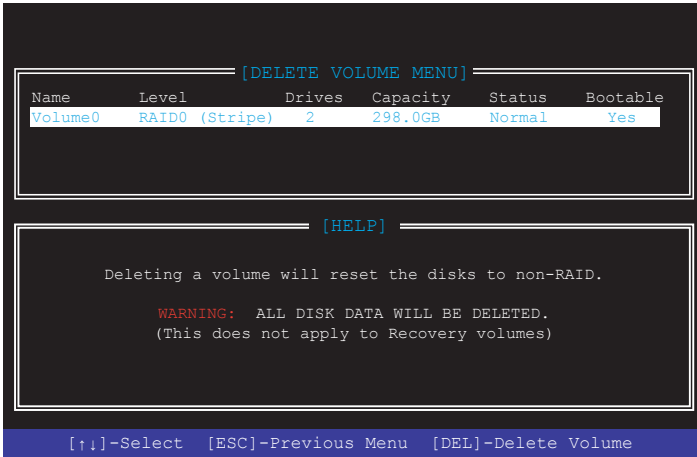

2. Use the up/down arrow key to select the RAID set you want to delete, and then press <Delete>. The following warning message appears:

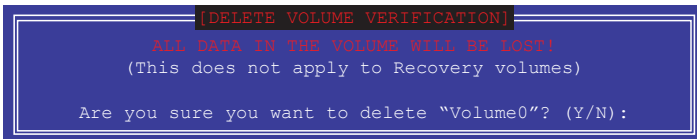

3. Press <Y> to delete the RAID set and return to the utility main menu, or press <N> to return to the DELETE VOLUME menu.

## Exiting the Intel® Rapid Storage Technology Option ROM utility

To exit the utility:

1. From the utility main menu, select **6. Exit**, then press <Enter>. The following warning message appears:

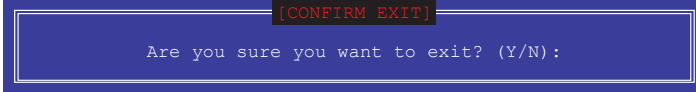

2. Press <Y> to exit or press <N> to return to the utility main menu.

## 4.2 Creating a RAID driver disk

### 4.2.1 Creating a RAID driver disk in Windows®

To install the RAID driver for Windows® OS:

1. During the OS installation, click **Load Driver** to allow you to select the installation media containing the RAID driver.
2. Insert the USB flash drive with RAID driver into the USB port or the support DVD into the optical drive, and then click **Browse**.
3. Click the name of the device you have inserted, and go to **Drivers > RAID**, then select the RAID driver for the corresponding OS version. Click **OK**.
4. Follow the succeeding screen instructions to complete the installation.



---

Before loading the RAID driver from a USB flash drive, you have to use another computer to copy the RAID driver from the support DVD to the USB flash drive.

---



---

To set up a Windows® UEFI operating system under RAID mode, ensure to load the UEFI driver for your optical drive.

---

# Appendix

## Notices

### Federal Communications Commission Statement

This device complies with Part 15 of the FCC Rules. Operation is subject to the following two conditions:

- This device may not cause harmful interference.
- This device must accept any interference received including interference that may cause undesired operation.

This equipment has been tested and found to comply with the limits for a Class B digital device, pursuant to Part 15 of the FCC Rules. These limits are designed to provide reasonable protection against harmful interference in a residential installation. This equipment generates, uses and can radiate radio frequency energy and, if not installed and used in accordance with manufacturer's instructions, may cause harmful interference to radio communications. However, there is no guarantee that interference will not occur in a particular installation. If this equipment does cause harmful interference to radio or television reception, which can be determined by turning the equipment off and on, the user is encouraged to try to correct the interference by one or more of the following measures:

- Reorient or relocate the receiving antenna.
- Increase the separation between the equipment and receiver.
- Connect the equipment to an outlet on a circuit different from that to which the receiver is connected.
- Consult the dealer or an experienced radio/TV technician for help.



---

The use of shielded cables for connection of the monitor to the graphics card is required to assure compliance with FCC regulations. Changes or modifications to this unit not expressly approved by the party responsible for compliance could void the user's authority to operate this equipment.

---

## IC: Canadian Compliance Statement

Complies with the Canadian ICES-003 Class B specifications. This device complies with RSS 210 of Industry Canada. This Class B device meets all the requirements of the Canadian interference-causing equipment regulations.

This device complies with Industry Canada license exempt RSS standard(s). Operation is subject to the following two conditions: (1) this device may not cause interference, and (2) this device must accept any interference, including interference that may cause undesired operation of the device.

Cet appareil numérique de la Classe B est conforme à la norme NMB-003 du Canada. Cet appareil numérique de la Classe B respecte toutes les exigences du Règlement sur le matériel brouilleur du Canada.

Cet appareil est conforme aux normes CNR exemptes de licence d'Industrie Canada. Le fonctionnement est soumis aux deux conditions suivantes:

- (1) cet appareil ne doit pas provoquer d'interférences et
- (2) cet appareil doit accepter toute interférence, y compris celles susceptibles de provoquer un fonctionnement non souhaité de l'appareil.

## Canadian Department of Communications Statement

This digital apparatus does not exceed the Class B limits for radio noise emissions from digital apparatus set out in the Radio Interference Regulations of the Canadian Department of Communications.

This class B digital apparatus complies with Canadian ICES-003.

## VCCI: Japan Compliance Statement

### Class B ITE

この装置は、クラスB情報技術装置です。この装置は、家庭環境で使用することを目的としていますが、この装置がラジオやテレビジョン受信機に近接して使用されると、受信障害を引き起こすことがあります。

取扱説明書に従って正しい取り扱いをして下さい。

VCCI-B

## KC: Korea Warning Statement

B급 기기 (가정용 방송통신기자재)

이 기기는 가정용(B급) 전자파적합기기로서 주로 가정에서 사용하는 것을 목적으로 하며, 모든 지역에서 사용할 수 있습니다.

\*당해 무선설비는 전파혼신 가능성이 있으므로 인명안전과 관련된 서비스는 할 수 없습니다.



## REACH

Complying with the REACH (Registration, Evaluation, Authorisation, and Restriction of Chemicals) regulatory framework, we published the chemical substances in our products at ASUS REACH website at <http://csr.asus.com/english/REACH.htm>.



DO NOT throw the motherboard in municipal waste. This product has been designed to enable proper reuse of parts and recycling. This symbol of the crossed out wheeled bin indicates that the product (electrical and electronic equipment) should not be placed in municipal waste. Check local regulations for disposal of electronic products.



DO NOT throw the mercury-containing button cell battery in municipal waste. This symbol of the crossed out wheeled bin indicates that the battery should not be placed in municipal waste.

## ASUS Recycling/Takeback Services

ASUS recycling and takeback programs come from our commitment to the highest standards for protecting our environment. We believe in providing solutions for you to be able to responsibly recycle our products, batteries, other components as well as the packaging materials. Please go to <http://csr.asus.com/english/Takeback.htm> for detailed recycling information in different regions.

## Regional notice for California

**WARNING!** This product may contain chemicals known to the State of California to cause cancer, birth defects or other reproductive harm. Wash hands after handling.

## RF Equipment Notices

### CE: European Community Compliance Statement

The equipment complies with the RF Exposure Requirement 1999/519/EC, Council Recommendation of 12 July 1999 on the limitation of exposure of the general public to electromagnetic fields (0–300 GHz). This wireless device complies with the R&TTE Directive.

### Wireless Radio Use

This device is restricted to indoor use when operating in the 5.15 to 5.25 GHz frequency band.

### Exposure to Radio Frequency Energy

The radiated output power of the Wi-Fi technology is below the FCC radio frequency exposure limits. Nevertheless, it is advised to use the wireless equipment in such a manner that the potential for human contact during normal operation is minimized.

## FCC Bluetooth Wireless Compliance

The antenna used with this transmitter must not be co-located or operated in conjunction with any other antenna or transmitter subject to the conditions of the FCC Grant.

## Bluetooth Industry Canada Statement

This Class B device meets all requirements of the Canadian interference-causing equipment regulations.

Cet appareil numérique de la Class B respecte toutes les exigences du Règlement sur le matériel brouilleur du Canada.

## NCC: Taiwan Wireless Statement

### 無線設備の警告聲明

經型式認證合格之低功率射頻電機，非經許可，公司、商號或使用者均不得擅自變更射頻、加大功率或變更原設計之特性及功能。低功率射頻電機之使用不得影響飛航安全及干擾合法通信；經發現有干擾現象時，應立即停用，並改善至無干擾時方得繼續使用。前項合法通信指依電信法規定作業之無線通信。低功率射頻電機須忍受合法通信或工業、科學及醫療用電波輻射性電機設備之干擾。

於 5.25GHz 至 5.35GHz 區域內操作之  
無線設備的警告聲明

工作頻率 5.250 ~ 5.350GHz 該頻段限於室內使用。

## Japan RF Equipment Statement

### 屋外での使用について

本製品は、5GHz帯域での通信に対応しています。電波法の定めにより5.2GHz、5.3GHz帯域の電波は屋外で使用が禁じられています。

### 法律および規制遵守

本製品は電波法及びこれに基づく命令の定めるところに従い使用してください。日本国外では、その国の法律または規制により、本製品の使用ができないことがあります。このような国では、本製品を運用した結果、罰せられることがあります。当社は一切責任を負いかねますのでご了承ください。

## Google™ License Terms

Copyright© 2016 Google Inc. All Rights Reserved.

Licensed under the Apache License, Version 2.0 (the "License"); you may not use this file except in compliance with the License. You may obtain a copy of the License at:

<http://www.apache.org/licenses/LICENSE-2.0>

Unless required by applicable law or agreed to in writing, software distributed under the License is distributed on an "AS IS" BASIS, WITHOUT WARRANTIES OR CONDITIONS OF ANY KIND, either express or implied.

See the License for the specific language governing permissions and limitations under the License.

**English** ASUSTeK Computer Inc. hereby declares that this device is in compliance with the essential requirements and other relevant provisions of Directive 1999/5/EC. Full text of EU declaration of conformity is available at: [www.asus.com/support](http://www.asus.com/support)

This device may be operated in the countries listed below:

**Français** ASUSTeK Computer Inc. déclare par la présente que cet appareil est conforme aux critères essentiels et autres clauses pertinentes de la directive 1999/5/CE. La déclaration de conformité de l'UE peut être téléchargée à partir du site Internet suivant: [www.asus.com/support](http://www.asus.com/support)

Cet appareil peut être utilisé dans les pays de la liste ci-dessous:

**Deutsch** ASUSTeK Computer Inc. erklärt hiermit, dass dieses Gerät mit den wesentlichen Anforderungen und anderen relevanten Bestimmungen der Richtlinie 1999/5/EC übereinstimmt. Der gesamte Text der EU-Konformitätserklärung ist verfügbar unter: [www.asus.com/support](http://www.asus.com/support)

Dieses Gerät darf in den unten aufgeführten Ländern betrieben werden:

**Italiano** ASUSTeK Computer Inc. con la presente dichiara che questo dispositivo è conforme ai requisiti essenziali e alle altre disposizioni pertinenti con la direttiva 1999/5/CE. Il testo completo della dichiarazione di conformità UE è disponibile all'indirizzo: [www.asus.com/support](http://www.asus.com/support)

Questo dispositivo può essere utilizzato nei paesi elencati qui di seguito:

**Русский** Компания ASUS заявляет, что это устройство соответствует основным требованиям и другим соответствующим условиям европейской директивы 1999/5/EC. Подробную информацию, пожалуйста, смотрите на [www.asus.com/support](http://www.asus.com/support)

Это устройство может работать в странах, которые приведены ниже:

**Български** С настоящото ASUSTeK Computer Inc. декларира, че това устройство е в съответствие със съществените изисквания и другите приложими постановления на Директива 1999/5/EC. Пълният текст на декларацията за съответствие на ЕС е достъпен на адрес: [www.asus.com/support](http://www.asus.com/support)

Устройството може да се използва във всички страни, посочени по-долу:

**Hrvatski** ASUSTeK Computer Inc. ovim izjavljuje da je ovaj uređaj skladan s bitnim zahtjevima i ostalim odgovarajućim odredbama direktive 1999/5/EC. Cijeli tekst EU izjave o skladnosti dostupan je na: [www.asus.com/support](http://www.asus.com/support)

Ovaj uređaj može se koristiti u dolje navedenim zemljama:

**Čeština** Společnost ASUSTEK Computer Inc. tímto prohlašuje, že toto zařízení splňuje základní požadavky a další příslušná ustanovení směrnice 1999/5/EC. Plné znění prohlášení o shodě EU je k dispozici na adrese: [www.asus.com/support](http://www.asus.com/support)

Toto zařízení lze používat v níže uvedených zemích:

**Dansk** ASUSTeK Computer Inc. erklærer hermed, at denne enhed er i overensstemmelse med hovedkravene og andre relevante bestemmelser i direktivet 1999/5/EC. Hele EU-overensstemmelseserklæringen kan findes på: [www.asus.com/support](http://www.asus.com/support)

Denne enhed kan bruges i landene, der står på listen nedenfor:

**Nederlands** ASUSTeK Computer Inc. verklaart hierbij dat dit apparaat voldoet aan de essentiële vereisten en andere relevante bepalingen van de verwante richtlijnen 1999/5/EC. De volledige tekst van de EU-verklaring van conformiteit is beschikbaar op: [www.asus.com/support](http://www.asus.com/support)

Dit apparaat kan worden gebruikt in de hieronder vermelde landen:

**Eesti** Käesolevaga kinnitab ASUSTEK Computer Inc., et see seade vastab Direktiivi 1999/5/EÜ asjakohaste direktiivide olulistele nõuetele ja teistele asjassepuutuvatele sätetele. EL vastavusdeklaratsiooni täielik tekst on saadaval järgmisel aadressil: [www.asus.com/support](http://www.asus.com/support)

Seda seadet võib kasutada altoolud riikides:

**Suomi** ASUSTEK Computer Inc. ilmoittaa täten, että tämä laite on on EY-direktiivin 1999/5/EC olellaisten vaatimusten ja muiden tätä koskevien säästöjen mukainen. EU-yhdenmukaisuusilmoituksen koko teksti on luettavissa osoitteessa: [www.asus.com/support](http://www.asus.com/support)

Tätä laitetta voidaan käyttää alla luetelluissa maissa:

**Ελληνικά** Με το παρόν, η ASUSTEK Computer Inc. δηλώνει ότι αυτή η συσκευή συμμορφώνεται με τις θεμελιώδεις απαιτήσεις και άλλες σχετικές διατάξεις της Οδηγίας 1999/5/ΕΕ. Το πλήρες κείμενο της δήλωσης συμμόρφωσης είναι διαθέσιμο στη διεύθυνση: [www.asus.com/support](http://www.asus.com/support)

Αυτή η συσκευή μπορεί να λειτουργήσει στις χώρες που αναφέρονται στη λίστα που ακολουθεί:

**Magyar** Az ASUSTEK Computer Inc. ezennel kijelenti, hogy ez az eszköz megfelel az 1999/5/EK Irányelv lényeges követelményeinek és egyéb vonatkozó rendelkezésének. Az EU megfelelésegi nyilatkozat teljes szövege innen letölthető: [www.asus.com/support](http://www.asus.com/support)

Az eszköz az alább felsorolt országokban működhető:

**Litviski** „ASUSTEK Computer Inc.” šiuo tvirtina, kad šis įrenginys atitinka pagrindinius reikalavimus ir kitas svarbias Direktyvos 1999/5 EB nuostatas. Visą ES atitikties deklaracijos tekstą galima rasti: [www.asus.com/support](http://www.asus.com/support)

Šio ierici var lietot tālak norādītajās valstīs:

**Lietuvių** ASUSTEK Computer Inc. eršio šio pazio, ka ši ierice atbilst Direktivos 1999/5/EK būtiskajam prasibam un citiem citiem saistojajiem nosaciumiem. Pilns ES atbilstibas paziņojuma teksts pieejams šeit: [www.asus.com/support](http://www.asus.com/support)

Šį įrenginį galima naudoti toliau išvardytose šalyse:

**Norsk** ASUSTEK Computer Inc. erklærer herved at denne enheten er i samsvar med hovedsaklige krav og andre relevante forskrifter i direktivet 1999/5/EF. Fullstendig tekst for EU-samsvarserklæringen finnes på: [www.asus.com/support](http://www.asus.com/support)

Enheten kan brukes i landene under:

**Polski** Firma ASUSTEK Computer Inc. niniejszym oświadczam, że urządzenie to jest zgodne z zasadniczymi wymogami i innymi właściwymi postanowieniami dyrektywy 1999/5/WE. Pełny tekst deklaracji zgodności UE jest dostępny pod adresem: [www.asus.com/support](http://www.asus.com/support)

Urządzenie to może być używane w wymienionych poniżej krajach:

**Português A** ASUSTEK Computer Inc. declara que este dispositivo está em conformidade com os requisitos essenciais e outras disposições relevantes da Diretiva 1999/5/CE. Texto integral da declaração da UE disponível em: [www.asus.com/support](http://www.asus.com/support)

Este dispositivo pode ser utilizado nos países indicados abaixo:

**Română** ASUSTEK Computer Inc. declară că acest dispozitiv se conformează cerințelor esențiale și altor prevederi relevante ale Directivei 1999/5/CE. Textul complet al declarației de conformitate a Uniunii Europene se găsește la: [www.asus.com/support](http://www.asus.com/support)

Puteți utiliza acest dispozitiv în țările următoare:

**Srpski** ASUSTEK Computer Inc. ovim izjavljuje da je ovaj uređaj u saglasnosti sa osnovnim zahtevima i drugim relevantnim odredbama Direktive 1999/5/EC. Pun tekst EU deklaracije o usaglasnosti je dostupan da adresi: [www.asus.com/support](http://www.asus.com/support)

Ovaj uređaj može da se koristi u državama navedenim ispod:

**Slovensky** Spoločnosť ASUSTEK Computer Inc. týmto vyhlasuje, že toto zariadenie vyhovuje základným požiadavkám a ostatým príslušným ustanoveniam smernice 1999/5/ES. Celý text vyhlásenia o zhode pre štáty EU je dostupný na adrese: [www.asus.com/support](http://www.asus.com/support)

Toto zariadenie môže byť prevádzkované v dolu uvedených krajinách:

**Slovensčina** ASUSTEK Computer Inc. izjavlja, da je ta naprava skladna z bistvenimi zahtevami in drugimi ustreznimi določbami Direktive 1999/5/ES. Celotno besedilo EU-izjave o skladnosti je na voljo na spletnem mestu: [www.asus.com/support](http://www.asus.com/support)

To napravo je mogoče uporabljati v spodaj navedenih državah:

**Español** Por la presente, ASUSTEK Computer Inc. declara que este dispositivo cumple los requisitos básicos y otras disposiciones pertinentes de la directiva 1999/5/EC. El texto completo de la declaración de la UE de conformidad está disponible en: [www.asus.com/support](http://www.asus.com/support)

Este dispositivo se puede utilizar en los países enumerados a continuación:

**Svenska** ASUSTEK Computer Inc. förklarar härmed att denna enhet överensstämmer med de grundläggande kraven och andra relevanta föreskrifter i direktiv 1999/5/EG. Fulltext av EU-försäkran om överensstämmelse finns på: [www.asus.com/support](http://www.asus.com/support)

Denna enhet kan användas i följande länder:

**Українська** ASUSTEK Computer Inc. заявляє, що цей пристрій відповідає основним вимогам та іншим відповідним положенням Директиви 1999/5/EC. Повний текст декларації відповідності стандартам ЄС доступний на: [www.asus.com/support](http://www.asus.com/support)

Цей пристрій можна експлуатувати у країнах зі списку нижче:

**Türkçe** ASUSTEK Computer Inc., bu aygıtın temel gereksinimlerle ve 1999/5/EC Yönergesinin diğer ilgili kullarıyla uyumlu olduğunu beyan eder. AB uygunluk bildirimini tam metni şu adreste bulabilirsiniz: [www.asus.com/support](http://www.asus.com/support)

Bu aygıt aşağıda listelenen ülkelere çalıştırılabilir:

**Bosanski** ASUSTEK Computer Inc. ovim izjavljuje da je ovaj uređaj uskladen sa bitnim zahtjevima i ostalim odgovarajućim odredbama direktive 1999/5/EC. Cijeli tekst EU izjave o uskladenosti dostupan je na: [www.asus.com/support](http://www.asus.com/support)

Ovaj uređaj može se koristiti u dolje navedenim zemljama:

AT	BE	BG	CH	CY	CZ	DE	DK
EE	ES	FI	FR	GB	GR	HU	IE
IT	IS	LI	LT	LU	LV	MT	NL
NO	PL	PT	RO	SE	SI	SK	TR

## ASUS contact information

### ASUSTeK COMPUTER INC.

Address 4F, No. 150, Li-Te Rd., Peitou, Taipei 112, Taiwan  
Telephone +886-2-2894-3447  
Fax +886-2-2890-7798  
Web site [www.asus.com](http://www.asus.com)

#### *Technical Support*

Telephone +86-21-38429911  
Fax +86-21-5866-8722, ext. 9101#  
Online support <http://qr.asus.com/techserv>

### ASUS COMPUTER INTERNATIONAL (America)

Address 800 Corporate Way, Fremont, CA 94539, USA  
Telephone +1-510-739-3777  
Fax +1-510-608-4555  
Web site <http://www.asus.com/us/>

#### *Technical Support*

Support fax +1-812-284-0883  
Telephone +1-812-282-2787  
Online support <http://qr.asus.com/techserv>

### ASUS COMPUTER GmbH (Germany and Austria)

Address Harkort Str. 21-23, 40880 Ratingen, Germany  
Fax +49-2102-959931  
Web site <http://www.asus.com/de>  
Online contact <http://eu-rma.asus.com/sales>

#### *Technical Support*

Telephone +49-2102-5789555  
Support Fax +49-2102-959911  
Online support <http://qr.asus.com/techserv>

## DECLARATION OF CONFORMITY

Per FCC Part 2 Section 2. 1077(a)



**Responsible Party Name:** Asus Computer International

**Address:** 800 Corporate Way, Fremont, CA 94539.

**Phone/Fax No:** (510)739-3777/(510)608-4555

hereby declares that the product

**Product Name :** Motherboard

**Model Number :** STRIX X99 GAMING

Conforms to the following specifications:

FCC Part 15, Subpart B, Unintentional Radiators

### Supplementary Information:

This device complies with part 15 of the FCC Rules. Operation is subject to the following two conditions: (1) This device may not cause harmful interference, and (2) this device must accept any interference received, including interference that may cause undesired operation.

Representative Person's Name : Steve Chang / President

A handwritten signature in blue ink that reads "Steve Chang".

Signature :

Date : Apr. 08, 2016

Ver. 140331

