



**THE ULTIMATE FORCE**

# **SABERTOOTH X99**

**ACCESSORY INSTALLATION GUIDE**

**ASUS<sup>®</sup>**  
IN SEARCH OF INCREDIBLE

E10097  
First Edition  
February 2015

Copyright © 2015 ASUSTeK COMPUTER INC. All Rights Reserved.

No part of this manual, including the products and software described in it, may be reproduced, transmitted, transcribed, stored in a retrieval system, or translated into any language in any form or by any means, except documentation kept by the purchaser for backup purposes, without the express written permission of ASUSTeK COMPUTER INC. ("ASUS").

Product warranty or service will not be extended if: (1) the product is repaired, modified or altered, unless such repair, modification or alteration is authorized in writing by ASUS; or (2) the serial number of the product is defaced or missing.

ASUS PROVIDES THIS MANUAL "AS IS" WITHOUT WARRANTY OF ANY KIND, EITHER EXPRESS OR IMPLIED, INCLUDING BUT NOT LIMITED TO THE IMPLIED WARRANTIES OR CONDITIONS OF MERCHANTABILITY OR FITNESS FOR A PARTICULAR PURPOSE. IN NO EVENT SHALL ASUS, ITS DIRECTORS, OFFICERS, EMPLOYEES OR AGENTS BE LIABLE FOR ANY INDIRECT, SPECIAL, INCIDENTAL, OR CONSEQUENTIAL DAMAGES (INCLUDING DAMAGES FOR LOSS OF PROFITS, LOSS OF BUSINESS, LOSS OF USE OR DATA, INTERRUPTION OF BUSINESS AND THE LIKE), EVEN IF ASUS HAS BEEN ADVISED OF THE POSSIBILITY OF SUCH DAMAGES ARISING FROM ANY DEFECT OR ERROR IN THIS MANUAL OR PRODUCT.

SPECIFICATIONS AND INFORMATION CONTAINED IN THIS MANUAL ARE FURNISHED FOR INFORMATIONAL USE ONLY, AND ARE SUBJECT TO CHANGE AT ANY TIME WITHOUT NOTICE, AND SHOULD NOT BE CONSTRUED AS A COMMITMENT BY ASUS. ASUS ASSUMES NO RESPONSIBILITY OR LIABILITY FOR ANY ERRORS OR INACCURACIES THAT MAY APPEAR IN THIS MANUAL, INCLUDING THE PRODUCTS AND SOFTWARE DESCRIBED IN IT.









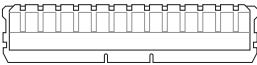
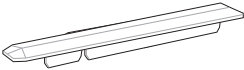
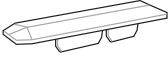

Products and corporate names appearing in this manual may or may not be registered trademarks or copyrights of their respective companies, and are used only for identification or explanation and to the owners' benefit, without intent to infringe.

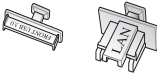
# Contents

<b>Contents</b> .....	<b>3</b>
<b>Package contents</b> .....	<b>4</b>
<b>Installing the assistant fans</b> .....	<b>5</b>
<b>Installing the M.2 card</b> .....	<b>6</b>
<b>Installing the Dust Defenders</b> .....	<b>7</b>
Installing the DIMM slot covers .....	7
Installing the PCIe x16, PCIe x4, and PCIe x1 slot covers .....	7
Installing the onboard connector caps .....	7
Installing the back I/O caps .....	8
<b>Installing the Thermistor cable</b> .....	<b>9</b>
<b>Contact Information</b> .....	<b>10</b>

## Package contents

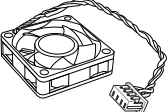
Check your SABERTOOTH X99 motherboard package for the following items:

 <p>4 x DIMM slot covers</p>  <p>2 x PCIe x16 slot covers</p>  <p>1 x PCIe x1 slot cover</p>  <p>1 x PCIe x4 slot cover</p>	 <p>1 x Connector cap set (LAN cap and Front USB 3.0 cap)</p>  <p>2 x Onboard USB 2.0 connector caps</p>  <p>9 x SATA connector caps</p>  <p>1 x SATA Express connector cap</p>  <p>11 x Back I/O USB connector caps</p>  <p>5 x Audio connector caps</p>
<b>TUF Connector Dust Defenders package</b>	
	
<b>TUF Accessory package</b>	<b>1 x 40 mm Assistant fan</b>
	
<b>3 x Thermistor cables</b>	<b>Accessory installation guide (this document)</b>



- If any of the above items is damaged or missing, contact your retailer.
- To support various models, your TUF Connector Dust Defenders package may include additional onboard connector caps and back I/O port caps.
- The illustrated items above are for reference only.

## Installing the assistant fans

The SABERTOOTH X99 motherboard package comes with a 40 mm assistant fan for additional cooling solution and better airflow.

To install the 40 mm assistant fan:

1. Remove the screws on the back I/O (A) then remove the back I/O fan cover lid (B).

Keep the screws for later use.

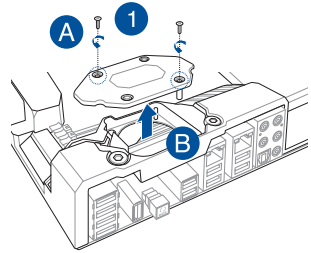

2. Connect the fan cable connector to the assistant fan (ASST\_FAN5) header on the motherboard.
3. Get the bundled 40 mm assistant fan and position it to an orientation where its THE ULTIMATE FORCE logo is facing upwards on the shield.
4. Secure the assistant fan with the screws that you removed in step 1.



Ensure to tuck the fan cable inside the cable corner slot.

5. Launch the Thermal Radar 2 utility on your computer to adjust the fan's behaviour.



For more information about the Thermal Radar 2 utility, refer to your motherboard's user guide.

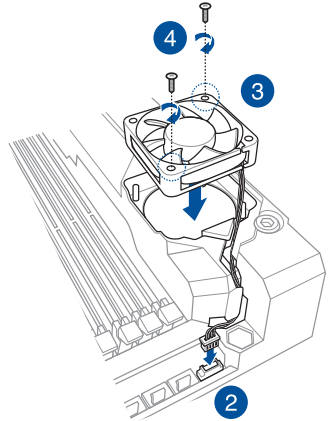

## Installing the M.2 card

The SABERTOOTH X99 motherboard allows you to install an M.2 card in the M.2 socket.



The M.2 card is purchased separately.

To install the M.2 card:

1. Loosen the screw on the M.2 socket cover lid.
2. Remove the M.2 socket cover lid.
3. Remove the screw in the M.2 socket.
4. Install the M.2 card into the M.2 socket, and then secure it with the screw that you removed in step 3.
5. Put back the M.2 socket cover lid.
6. Fasten the screw on the M.2 socket cover lid.

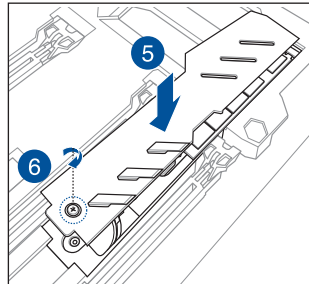
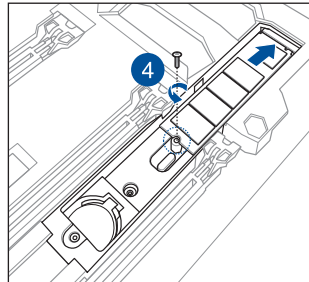
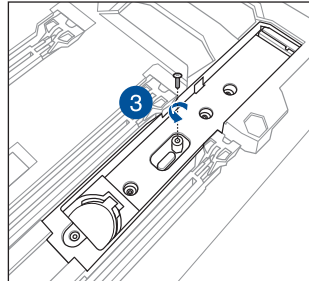
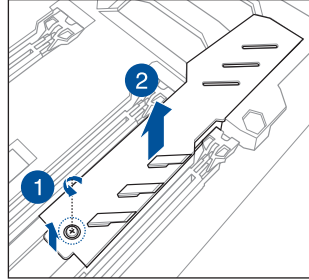

The location of the secure screw in the M.2 socket can be adjusted based on the length (normally 3 sizes: 80mm/60mm/42mm) of the M.2 card you use.

## Installing the Dust Defenders

The Dust Defenders are designed to prevent dust and small particles from building up in the motherboard's expansion and memory slots or connectors.

## Installing the DIMM slot covers

Install the DIMM slot covers into unused DIMM slots on your motherboard.

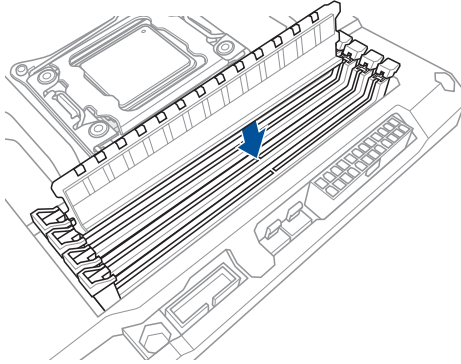

## Installing the PCIe x16, PCIe x4, and PCIe x1 slot covers

Install the PCIe x16, PCIe x4, or PCIe x1 slot covers into unused PCIe x16, PCIe x4, or PCIe x1 slots on your motherboard.

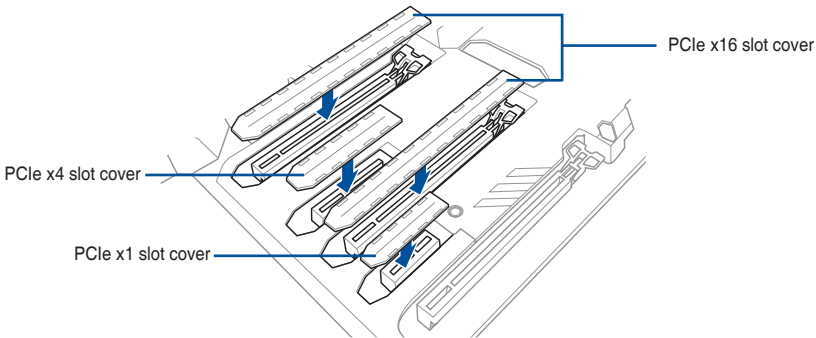

## Installing the onboard connector caps

Install the onboard connector caps into unused SATA or Onboard USB 3.0/2.0 connectors on your motherboard.



To support various models, your package may include additional onboard connector caps for your motherboard.

## Installing the back I/O caps

The SABERTOOTH X99 accessory package takes protection to the next level with the back I/O port caps.

Refer to the illustrated guide for the proper placement of back I/O caps:

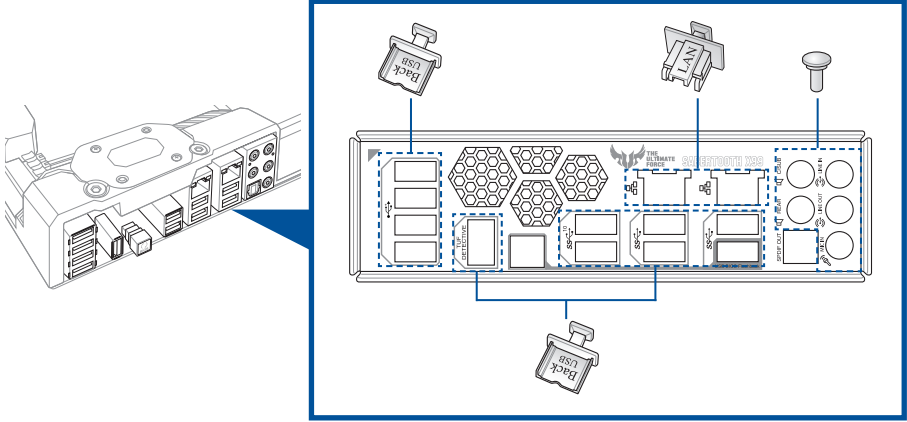

To support various models, your package may include additional back I/O port caps for your motherboard.



# Installing the Thermistor cable

The Thermistor cable works together with the Thermal Radar 2 utility to allow you to monitor the temperature of selected devices or critical components inside your motherboard.

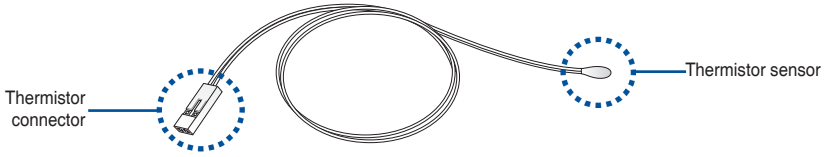

To install the Thermistor cable:

1. Locate the thermal sensor headers labeled T\_SENSOR1, T\_SENSOR2, or T\_SENSOR3 on your motherboard then connect the thermistor cable connector to any of these headers.

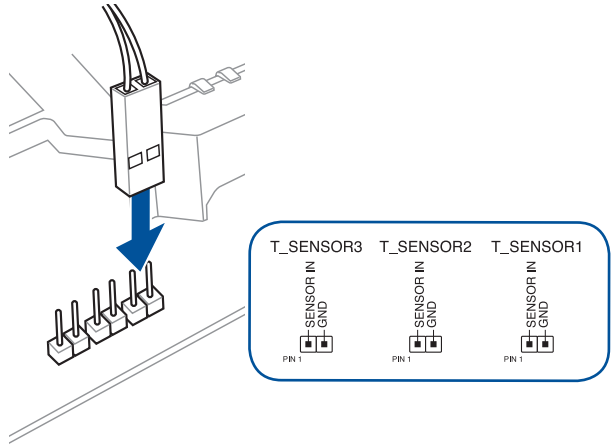

2. Put the thermistor sensor in contact with the surface of the component or part you want to monitor and secure it with an adhesive tape.



The adhesive tape is purchased separately.



The Thermistor sensor operating temperature ranges from 0°C – 80°C.

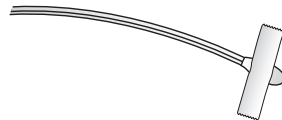

3. Launch the Thermal Radar 2 utility on your computer.

## Contact Information

### ASUSTeK COMPUTER INC.

Address 15 Li-Te Road, Peitou, Taipei, Taiwan 11259  
Telephone +886-2-2894-3447  
Fax +886-2-2890-7798  
E-mail [info@asus.com.tw](mailto:info@asus.com.tw)  
Web site <http://www.asus.com>

#### *Technical Support*

Telephone +86-21-3842-9911  
Fax +86-21-5866-8722, ext. 9101#  
Online support <http://support.asus.com/techserv/techserv.aspx>

### ASUS COMPUTER INTERNATIONAL (America)

Address 800 Corporate Way, Fremont, CA 94539, USA  
Telephone +1-510-739-3777  
Fax +1-510-608-4555  
Web site <http://usa.asus.com>

#### *Technical Support*

Support fax +1-812-284-0883  
General support +1-812-282-2787  
Online support <http://support.asus.com/techserv/techserv.aspx>

### ASUS COMPUTER GmbH (Germany and Austria)

Address Harkort Str. 21-23, 40880 Ratingen, Deutschland  
Fax +49-2102-959931  
Web site <http://www.asus.de>  
Online contact <http://eu-rma.asus.com/sales>

#### *Technical Support*

Telephone +49-2102-5789555  
Support Fax +49-2102-959911  
Online support <http://support.asus.com/techserv/techserv.aspx>

## Where to find more information

Visit [www.asus.com](http://www.asus.com) for additional information and product updates.



